

1 2 3 4 5 6 7 8

F

E

D

C

B

A

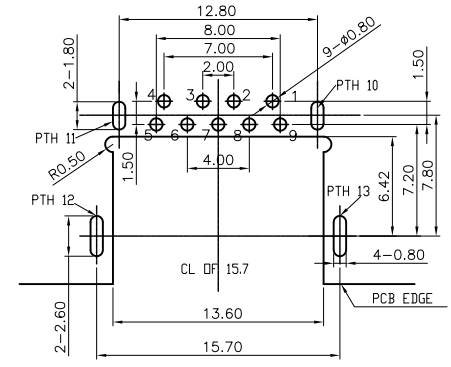
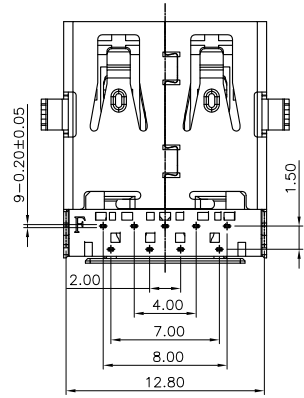
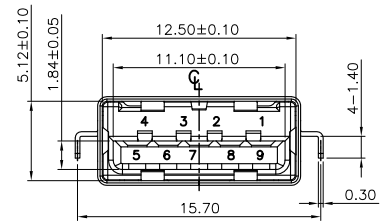
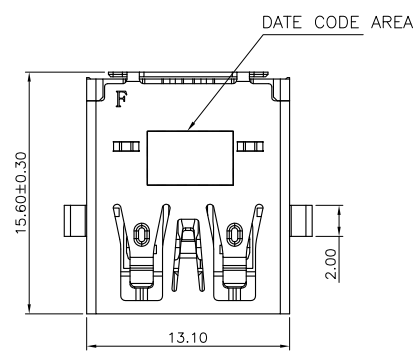

THICKNESS: 1.0mm
RECOMMENDED PCB LAYOUT
(TOP VIEW)

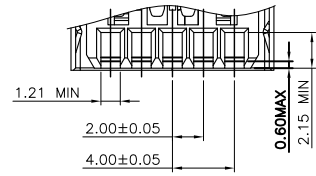
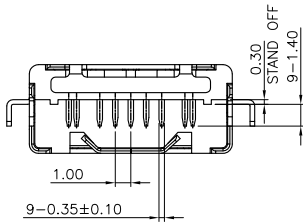
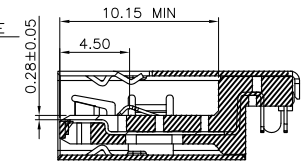
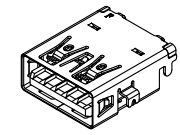
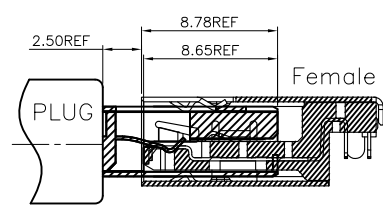
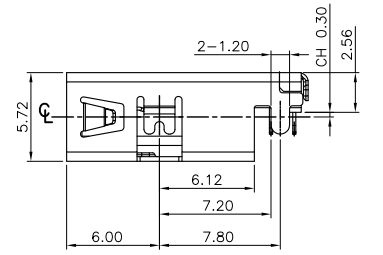

NOTE:

- 1. MATERIAL:
 - 1.1 INSULATOR: PA9T BLACK UL 94 V-0
 - 1.2 CONTACT (4pin): C5191 (T=0.20mm)
 - 1.3 CONTACT (5pin): C2680 (T=0.20mm)
 - 1.4 SHELL: SUS 304 (T=0.30mm)
- 2. ELECTRICAL CHARACTERISTICS:
 - 2.1 CONTACT RESISTANCE: 30mΩ MAXIMUM
 - 2.2 CONTACT CURRENT RATING: 1.5A
 - 2.3 DIELECTRIC WITHSTANDING VOLTAGE: 100 V R. M. S.
 - 2.4 INSULATION RESISTANCE 100 MEGOHMS MIN
 - 2.5 OPERATING TEMPERATURE: -40° C ~ 85° C
- 3. MECHANICAL CHARACTERISTICS:
 - 3.1 MATING FORCE: 3.5kg MAX
 - 3.2 UNMATED FORCE: 1.02kg MIN
 - 3.3 DURABILITY: MANDATORY: 5,000 CYCLES
 - 3.4 EXTRACTION FORCE: 0.8kg MIN
- 4. PLATING
 - 4.1 TERMINAL:
 - 50u" MIN NICKEL ALL OVER
 - 80u" MIN Tin ON SOLDER AREA
 - (1~30)u" Au ON CONTACT AREA
 - 4.2 SHELL: 50u" MIN. NICKEL ALL OVER

P/N. : 2UB09-1764-XX0H

CONTACT AREA PLATING
 00: G/F
 03: Au 3u"
 05: Au 5u"
 10: Au 10u"
 15: Au 15u"
 30: Au 30u"

UNLESS OTHERWISE SPECIFIED TOLERANCES

DECIMALS:		ANGLES:	
DIM	TOL	DIM	TOL
X.	±0.50	X.	±2°
X.X	±0.30	X.X	±1°
X.XX	±0.20	X.XX	///
X.XXX	±0.10	X.XXX	///

Singatron Enterprise Co., Ltd.

TITLE	USB 3.0 AF		
DWN	Tony	PART NO. 2UB09-1764-XX0H	
CHKD	2023.5.7	SCALE 1:1	UNIT: mm
APVD	Andy	SIZE: A3	SHEET: 1 OF 2
		REV: A1	

CUSTOMER COPY

1 2 3 4 5 6 7 8

1 2 3 4 5 6 7 8

F

E

D

C

B

A

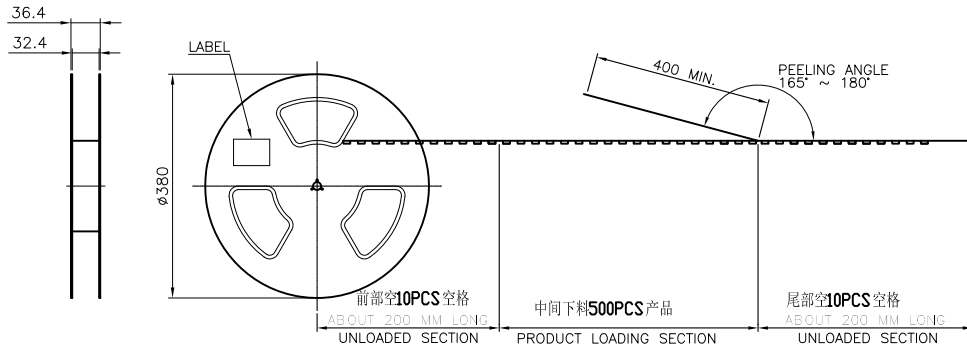

USER DIRECTION OF UNREELING →

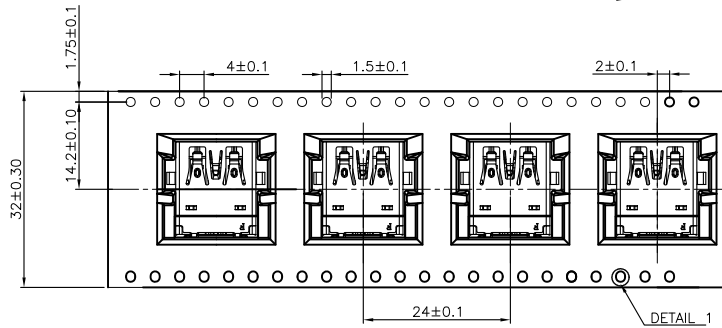

NOTE:

- MATERIAL:
 BOX: FIBRE BOARD, CORRUGATED, DOUBLE WALL.
 TAPE: POLYSTYRENES, HEAT-RESISTANT TEMPERATURE: 120°C, Transparent COLOR (透明色).
 REEL: POLYSTYRENES, HEAT-RESISTANT TEMPERATURE: 70°C, BLUE COLOR.
 BAG: POLYETHYLENE, HEAT-RESISTANT TEMPERATURE: 100°C.
- PEELING STRENGTH: 0.1 ~ 1.3 N (10 ~ 130 GRAMS)
- PEELING SPEED: 300 mm/min.
- EACH BAG SHALL BE INCLUDED DESICCANT.

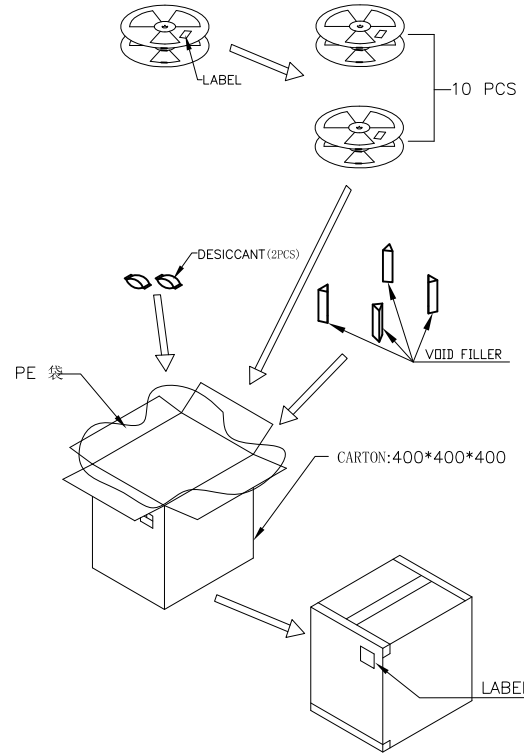
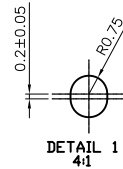

500 PCS/ REEL	10 REELS/ CARTON	5000 PCS QUANTITY	--KG GROSS WEIGHT	--KG NET WEIGHT	1.58g SINGLE WEIGHT
---------------	------------------	-------------------	-------------------	-----------------	---------------------

UNLESS OTHERWISE SPECIFIED TOLERANCES

DECIMALS:		ANGLES:	
DIM	TOL	DIM	TOL
X.	±0.50	X.	±2°
X.X	±0.30	X.X	±1°
X.XX	±0.20	X.XX	±1'
X.XXX	±0.10	X.XXX	±10'

Singatron Enterprise Co., Ltd.

TITLE	USB 3.0 AF				
DWN	Tony	PART NO. 2UB09-1764-XX0H			
CHKD	2023.5.7	SCALE 1:1	UNIT: mm		
APVD	Andy	SIZE: A3	SHEET: 2 OF 2	REV: A1	

CUSTOMER COPY

1 2 3 4 5 6 7 8