

NOTE:
 1.MATERIAL:
 1.1 INSULATOR:LCP+30%GF, UL94 V-0.
 1.2 CONTACT 1~4PIN: C5191-EH.
 1.3 CONTACT 5~9PIN: C5191-EH.
 1.4 SHELL: SUS304 3/4H
 2. PLATING:
 2.1 CONTACT:
 CONTACT AREA: GOLD PLATING.
 SOLDER AREA: 100u" Min MATTE TIN PLATING.
 UNDER PLATE: 50u" Min NICKEL PLATING.
 2.2 SHELL:50u" Min. NICKEL PLATED OVERALL
 3. CHARACTERISTICS:
 3.1 ELECTRICAL CHARACTERISTICS;
 CONTACT RESISTANCE:30mΩ MAXIMUM
 CONTACT CURRENT RATING: 3A
 DIELECTRIC WITHSTANDING VOLTAGE: 500 V R.M.S.
 INSULATION RESISTANCE: 100 MEGOHMS MIN
 OPERATING TEMPERATURE: -25°C ~ +85°C
 3.2 MECHANICAL:
 MATING FORCE: 8N-20N.
 UNMATING FORCE: 8N-20N.
 4.PART MUST COMPLY ROHS SPECIFICATION
 5.WAVE SOLDER:THE CONNECTOR SHALL BE MOUNTED ON THE PCB.THE TEMPERATURE OF THE SOLDER SHALL BE 260±5 °C AND IMMERSION DURATION 5 SECONDS.

P/N.: 2UB09-1765-X00H
 COLOR:
 1: BLACK
 2: BLUE

Pin NUMBER	SIGNAL NAME
1	VBUS
2	D-
3	D+
4	GND
5	StdA_SSRX-
6	StdA_SSRX+
7	GND_DRAIN
8	StdA_SSTX-
9	StdA_SSTX+
Shell	Shield

NO.	PART NAME	MATERIAL	DESCRIPTION
3	SHELL	SUS304-3/4H	50u" Min. NICKEL PLATED OVERALL
2	CONTACT	C5191-EH	GOLD PLATED ON CONTACT AREA
1	HSG	LCP+30%GF	UL94V-0

TOLERANCE: ±0.05, RECOMMENDED PCB LAYOUT (TOP VIEW)

UNLESS OTHERWISE SPECIFIED TOLERANCES		Singatron Enterprise Co., Ltd.			
DECIMALS:	ANGLES:	TITLE	USB A TYPE 3.1 沉板 10Gbps H=2.11MM		
DIM	TOL	DWN	Tony	PART NO.	2UB09-1765-X00H
X.	±0.50	CHKD	2023.5.7	SCALE	1:1
X.X	±0.30	APVD	Andy	SIZE	A3
X.XX	±0.20			SHEET	1 OF 2
X.XXX	±0.10			REV:	A1
				CUSTOMER COPY	

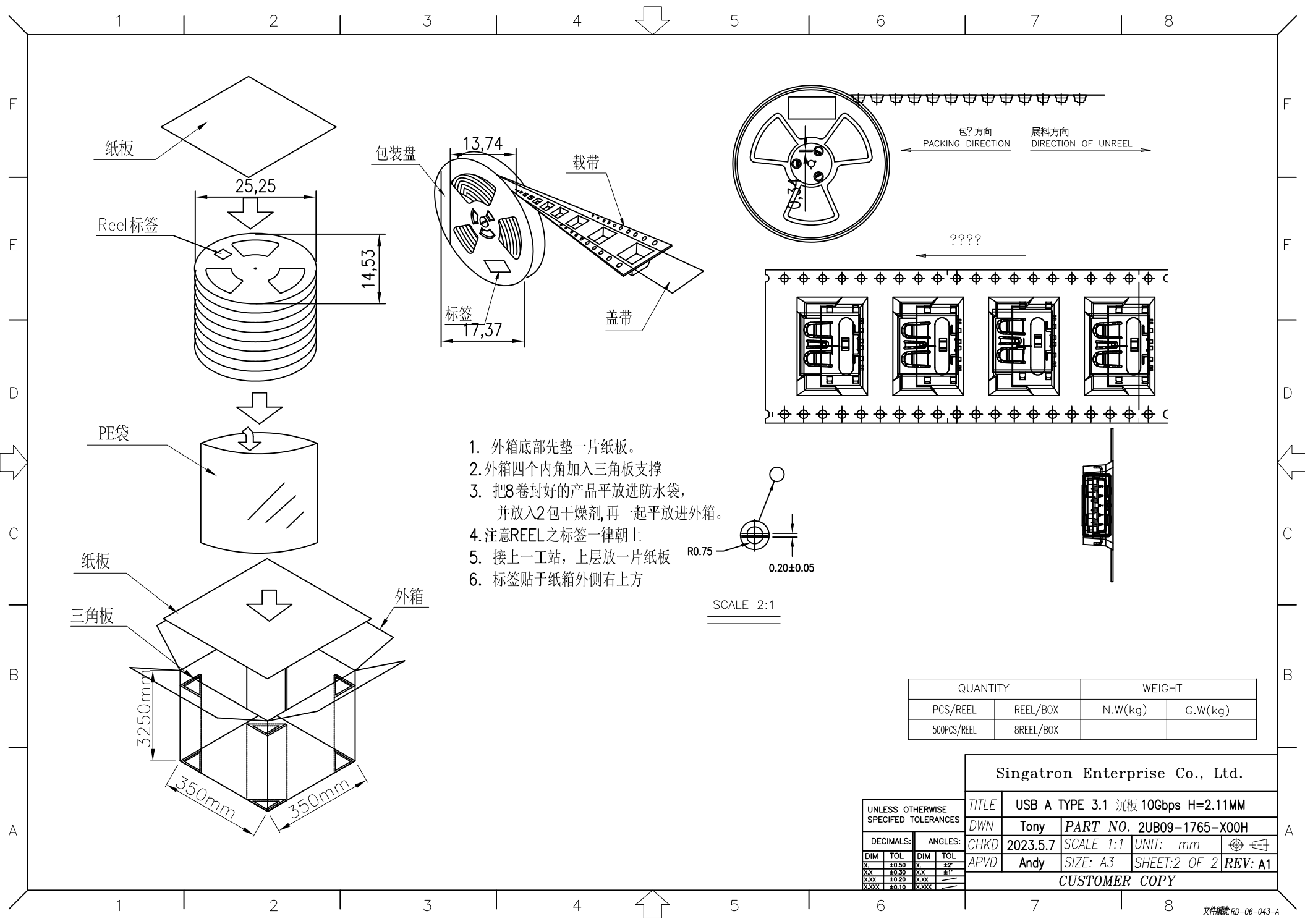

1. 外箱底部先垫一片纸板。
2. 外箱四个内角加入三角板支撑
3. 把8卷封好的产品平放进防水袋，并放入2包干燥剂，再一起平放进外箱。
4. 注意REEL之标签一律朝上
5. 接上一工站，上层放一片纸板
6. 标签贴于纸箱外侧右上方

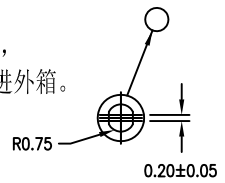

SCALE 2:1

QUANTITY		WEIGHT	
PCS/REEL	REEL/BOX	N.W(kg)	G.W(kg)
500PCS/REEL	8REEL/BOX		

UNLESS OTHERWISE SPECIFIED TOLERANCES			
DECIMALS:		ANGLES:	
DIM	TOL	DIM	TOL
X	±0.50	X	±2°
X.X	±0.30	X.X	±1°
X.XX	±0.20	X.XX	
X.XXX	±0.10	X.XXX	

Singatron Enterprise Co., Ltd.			
TITLE	USB A TYPE 3.1 沉板 10Gbps H=2.11MM		
DWN	Tony	PART NO. 2UB09-1765-X00H	
CHKD	2023.5.7	SCALE 1:1	UNIT: mm
APVD	Andy	SIZE: A3	SHEET: 2 OF 2
		REV: A1	
CUSTOMER COPY			