

1 2 3 4 5 6 7 8

F

E

D

C

B

A

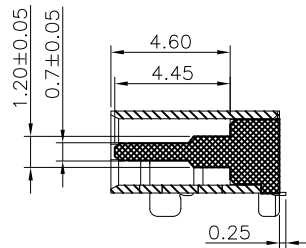
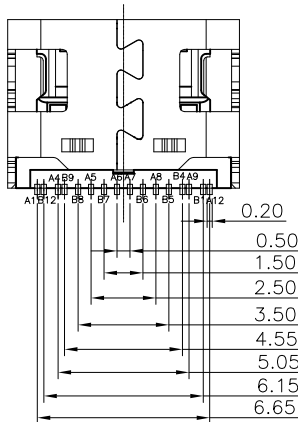
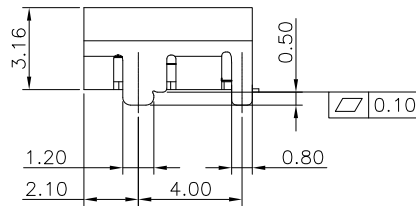
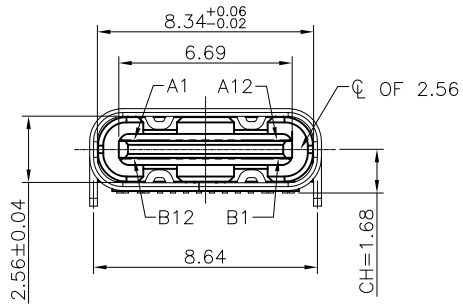
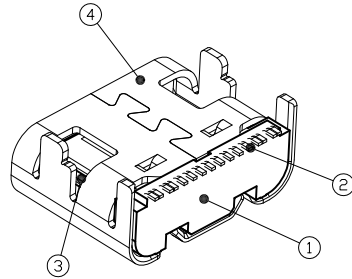
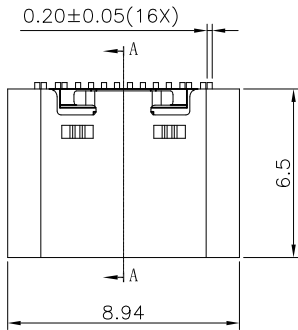

SECTION:A-A

NOTE:

- 1.MATERIAL SPECIFICATION:
  - 1.HOUSING:HIGH TEMPERATURE RESISTANT PLASTIC,UL94 V-0.
  - 2.CONTACTS:COPPER ALLOY
  - 3.MID PLATE: STAINLESS STEEL
  - 4.FRONT SHELL: STAINLESS STEEL
- 2.PLATING SPECIFICATION:
  - 2-1.CONTACTS:
    - Ni 50u" MIN. UNDER PLATED OVER ALL.
    - Au PLATED ON THE FUNCTIONAL AREA OF CONTACT.
    - (GOLD PLATING THICKNESS FOLLOW THE P/N)
    - PLATING SPECIFICATIONS OF THE SOLDER AREA FOLLOW THE P/N
  - 2-2.FRONT SHELL:
    - Ni 30u" MIN. UNDER PLATED OVER ALL.
  - 2-3.MID PLATE:
    - CLEAR ONLY
- 3.MECHANICAL PERFORMANCE,
  - 3-1.INSERTION FORCE: 0.5~2.0kgf.
  - 3-2.REMOVAL FORCE: 0.8kgf~2.0kgf.
  - 3-3.DURABILITY: 10000 CYCLES.
- 4.ELECTRICAL PERFORMANCE,
  - 4-1. CURRENT RATING:5.0A  
VOLTAGE RATING:5.0V
  - 4-2. LLCR:
    - VBUS & GND PINS AND OTHER PINS: 40mΩ/PIN MAX.
    - SHIELD: 50mΩ/MAX.
    - LLCR MAX. CHANGE OF ALL PINS: 10mΩ.
  - 4-3.INSULATION RESISTANCE: 100MΩ MIN
  - 4-4.DIELECTRIC WITHSTAND VOLTAGE,AC 100V FOR 1 MINUTE.
5. ENVIRONMENTAL PERFORMANCE:
  - OPERATING TEMPERATURE: -25°C~+85°C.
- 6.IR REFLOW:
  - THE PEAK TEMPERATURE ON THE BOARD SHALL BE MAINTAINED FOR 10 SECONDS AT 260°C.

UNLESS OTHERWISE SPECIFIED TOLERANCES				Singatron Enterprise Co., Ltd.			
DECIMALS:		ANGLES:		TITLE	USB CF 16PIN (L=6.5) TOP MOUNT		
DIM	TOL	DIM	TOL	DWN	Tony	PART NO. 2UB0TC16-0744-0XXXXH	
X.	±0.50	X.	±2°	CHKD	2019.5.10	SCALE 1:1	UNIT: mm
X.X	±0.30	X.X	±1°	APVD	Andy	SIZE: A3	SHEET: 1/3
X.XX	±0.20	X.XX	—	REV: A1			
X.XXX	+0.10	X.XXX	—	<b>CUSTOMER COPY</b>			

1 2 3 4 5 6 7 8

1 2 3 4 5 6 7 8

F

E

D

C

B

A

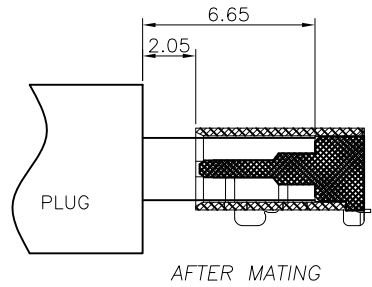

USB TYPE-C PIN ASSIGNMENTS

PIN NUMBER	SIGNAL NAME	PIN NUMBER	SIGNAL NAME
A1	GND	B12	GND
A4	VBUS	B9	VBUS
A5	CC1	B8	SBU2
A6	Dp1	B7	Dn2
A7	Dn1	B6	Dp2
A8	SBU1	B5	CC2
A9	VBUS	B4	VBUS
A12	GND	B1	GND

TABLE 1

P/N: 2UB0TC16-0744-0XXXXXH

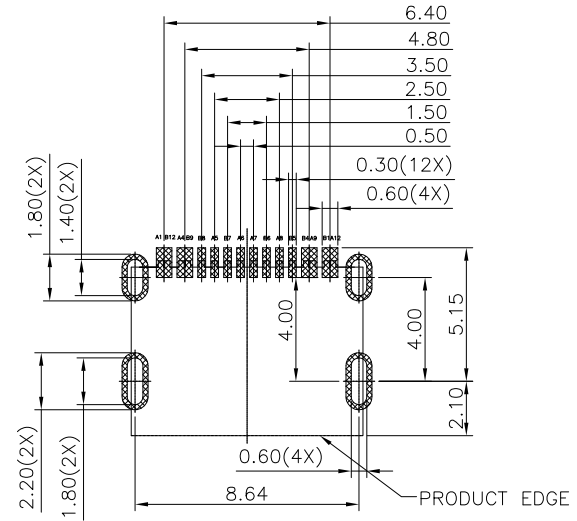
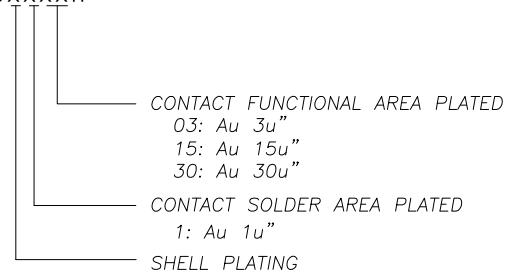

RECOMMENDED PCB LAYOUT(TOP VIEW)  
THICKNESS 0.60MM;DEFAULT TOLERANCE:±0.05

UNLESS OTHERWISE SPECIFIED TOLERANCES				Singatron Enterprise Co., Ltd.			
DECIMALS:		ANGLES:		TITLE	USB CF 16PIN (L=6.5) TOP MOUNT		
DIM	TOL	DIM	TOL	DWN	Tony	PART NO. 2UB0TC16-0744-0XXXXH	
X	±0.50	X	±2°	CHKD	2019.5.10	SCALE 1:1	UNIT: mm
X.X	±0.30	X.X	±1°	APVD	Andy	SIZE: A3	SHEET: 2/3
X.XX	±0.20	X.XX		REV: A1			
X.XXX	+0.10	X.XXX		CUSTOMER COPY			

1 2 3 4 5 6 7 8

1 2 3 4 5 6 7 8

F  
E  
D  
C  
B  
A

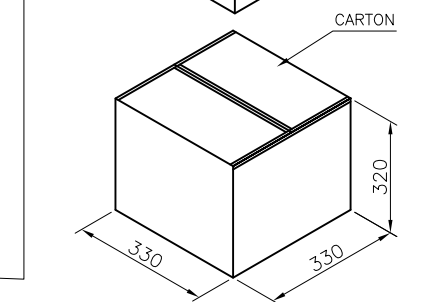
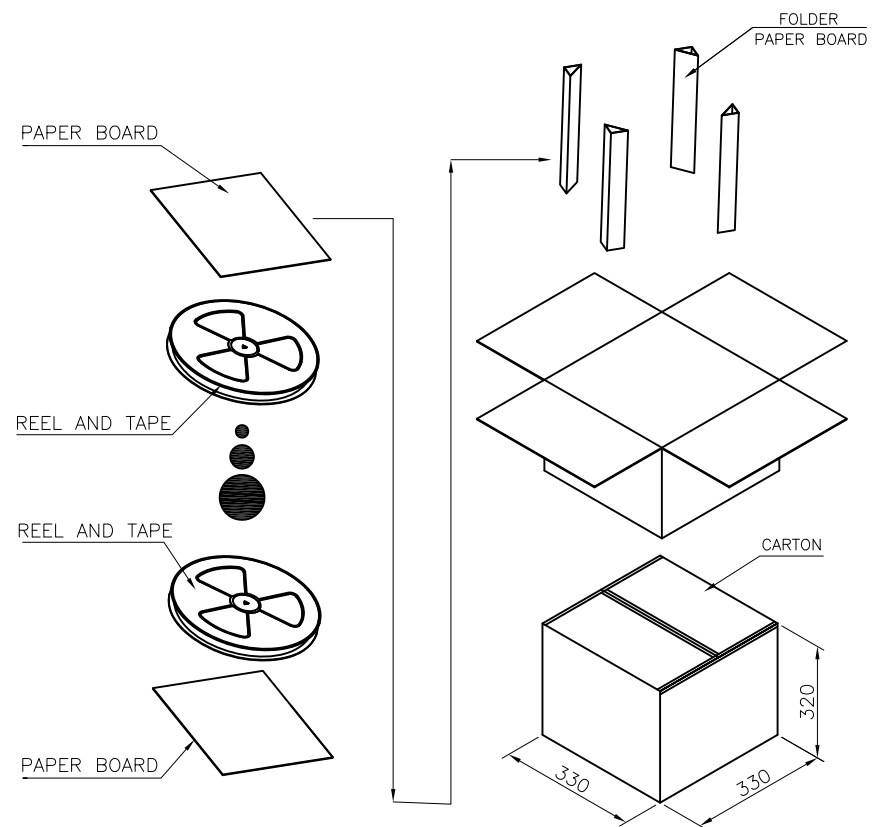
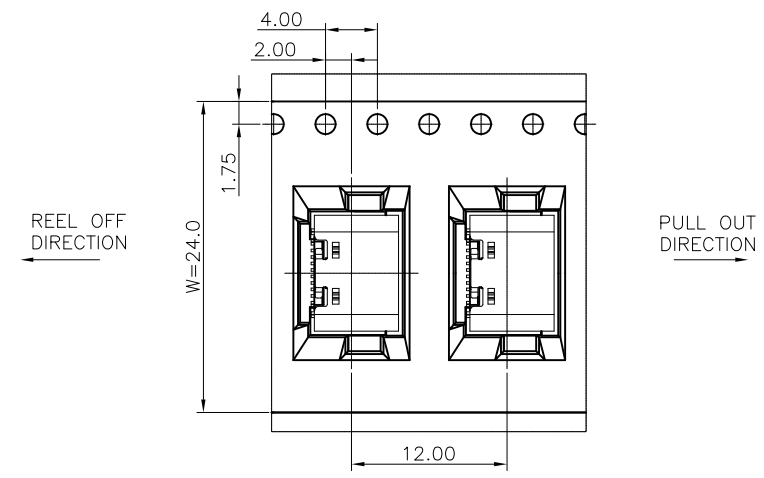
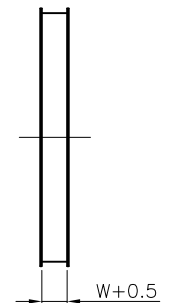
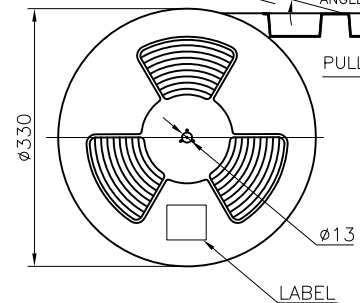
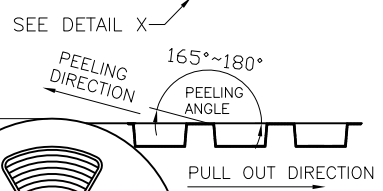
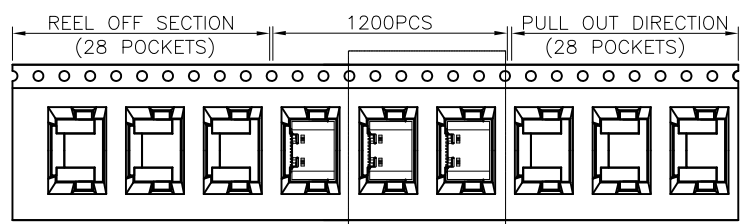

	REEL	CARTON
CONNECTOR (PCS)	1200	12000

UNLESS OTHERWISE SPECIFIED TOLERANCES				Singatron Enterprise Co., Ltd.			
DECIMALS:		ANGLES:		TITLE	USB CF 16PIN (L=6.5) TOP MOUNT		
DIM	TOL	DIM	TOL	DWN	Tony	PART NO. 2UB0TC16-0744-0XXXXH	
X.	±0.50	X.	±2°	CHKD	2019.5.10	SCALE 1:1	UNIT: mm
X.X	±0.30	X.X	±1°	APVD	Andy	SIZE: A3	SHEET: 3/3
X.XX	±0.20	X.XX		REV: A1			
X.XXX	+0.10	X.XXX		CUSTOMER COPY			

1 2 3 4 5 6 7 8