

RoHS Compliant

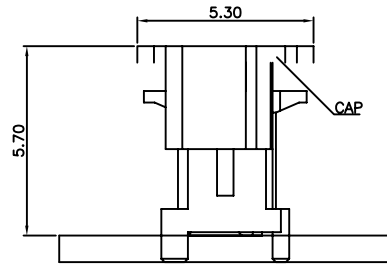

ASSEMBLY WITH CAP

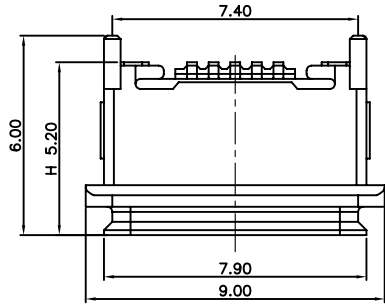
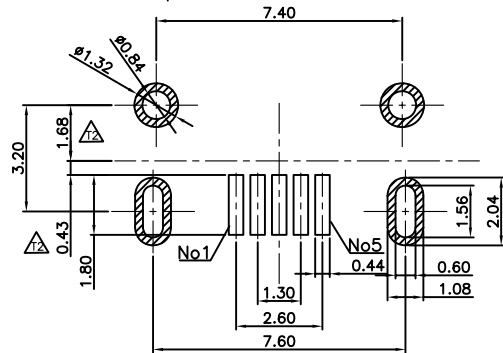
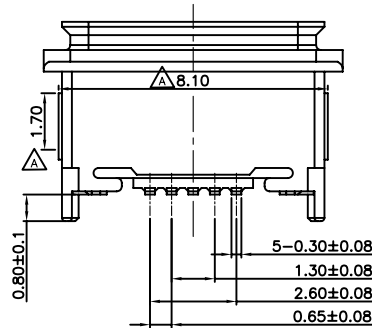
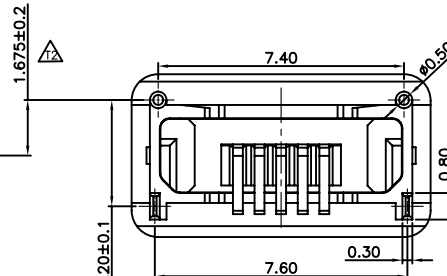
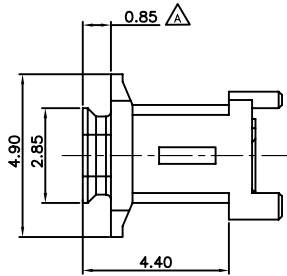
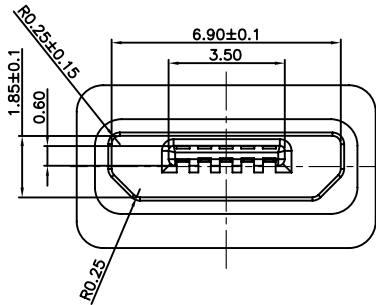

RECOMMENDED PCB LAYOUT
TOLERANCE: ±0.03mm
RECOMMEND PCB THICKNESS: 0.80mm

NOTES:

- MATERIAL:
HOUSING: THERMOPLASTIC HIGH-TEMP UL94V-0 BLACK COLOR.
CONTACT: COPPER ALLOY.
SHELL: STAINLESS STEEL.
- FINISH:
CONTACT: SEE TABLE 1.
OUT SHELL: 50u" Min. NICKEL ALL OVER
- APPLIED TO IR SOLDERING PROCESS.
- SPECIFICATION:
4.1. ELECTRICAL CHARACTERISTICS
CONTACT CURRENT RATING: Signal pin 1A, Power pin 1.8A
VOLTAGE RATING: 30V AC rms.
CONTACT RESISTANCE: 30mΩ MAX.
DIELECTRIC WITHSTANDING VOLTAGE:
UNMATEP CONTACT 100V AC rms. 60MHZ FOR 1 MINUTE.
INSULATION RESISTANCE: 1000MΩ MIN. 100V DC
TEMPERATURE RANGE: -30°C TO +85°C
4.2. MECHANICAL:
INSERTION FORCE: 35N MAX.
WITHDRAWAL FORCE: 8N~25N.
DURABILITY: 10,000 CYCLES

2UB1181-61X36-22A

- 1: Tray 2: Tape reel
1: G/F 2: 5u" 3: 10u" 4: 15u" 5: 30u"

Singatron Enterprise Co., Ltd.

TITLE	MICRO USB BF VERTICAL H5.20mm waterproof IPX8			
DWN	GAORUI	PART NO. 2UB1181-61X36-22A		
CHKD	2018.05.15	SCALE 1:1	UNIT: mm	
APVD		SIZE: A3	SHEET: 1/3	REV: A
CUSTOMER COPY				

REV.	DESCRIPTION	ECN NO.	DWN.	CHK.	APVD.	DATE	TOLERANCES UNLESS OTHERWISE SPECIFIED
A	修改外观结构	201901230024	GAORUI	Chain	DC.Feng	2019.01.23	X. ±0.50
T2	修改产品结构及尺寸标注	20180616001	GAORUI	Chain	DC.Feng	2018.06.16	X.X ±0.30
T1	RELEASE		GAORUI	Chain	DC.Feng	2018.05.15	X.XX ±0.20
							X.XXX ±0.10
							ANGEL ±1°

RoHS Compliant

机壳面板对密封圈
与缩量0.40Min

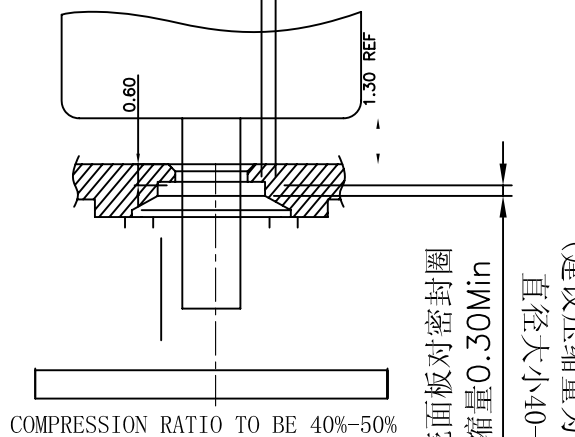

机壳面板对密封圈
与缩量0.30Min
(建议压缩量为密封圈
直径大小40-50%)

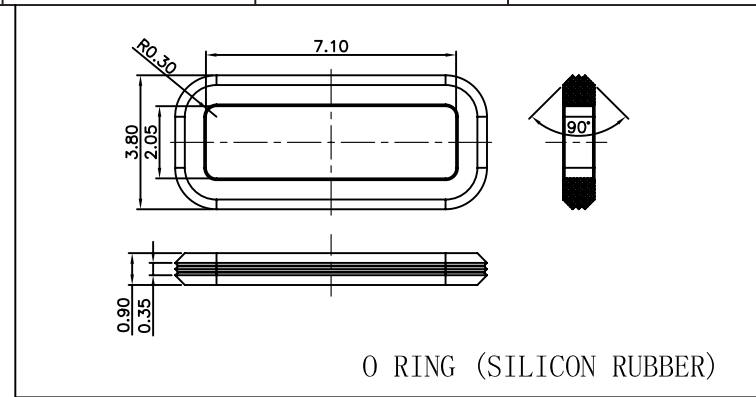

O RING (SILICON RUBBER)

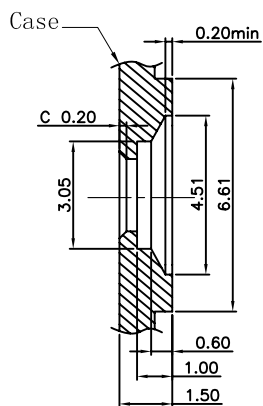
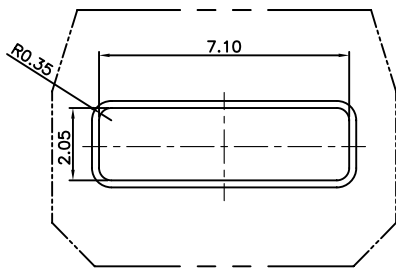

RECOMMENDED OPEN DIMENSION OF CASE
TOLERANCE: $\pm 0.03\text{mm}$
MATTING AREA WITH SEALING RING

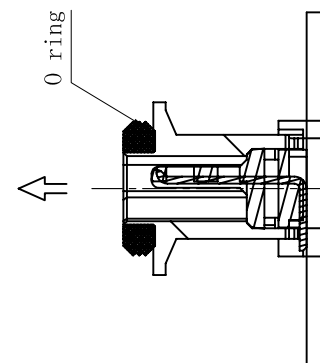
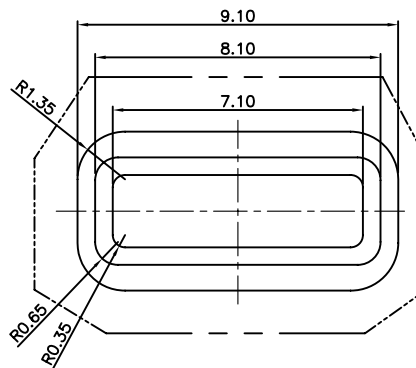

Singatron Enterprise Co., Ltd.

TITLE	MICRO USB BF VERTICAL H5.20mm waterproof IPX8			
DWN	GAORUI	PART NO.	2UB1181-61X36-22A	
CHKD	2018.05.15	SCALE	1:1	UNIT: mm
APVD		SIZE	A3	SHEET: 2/3
REV: A				
CUSTOMER COPY				

REV.	DESCRIPTION	ECN NO.	DWN.	CHK.	APVD.	DATE
A	修改外形结构	201901230024	GAORUI	Chain	DC.Feng	2019.01.23
T2	修改产品结构及尺寸标注	20180616001	GAORUI	Chain	DC.Feng	2018.06.16
T1	RELEASE		GAORUI	Chain	DC.Feng	2018.05.15

TOLERANCES UNLESS OTHERWISE SPECIFIED	
X.	± 0.50
X.X	± 0.30
X.XX	± 0.20
X.XXX	± 0.10
ANGEL	$\pm 1^\circ$

RoHS Compliant

30.5
24.5

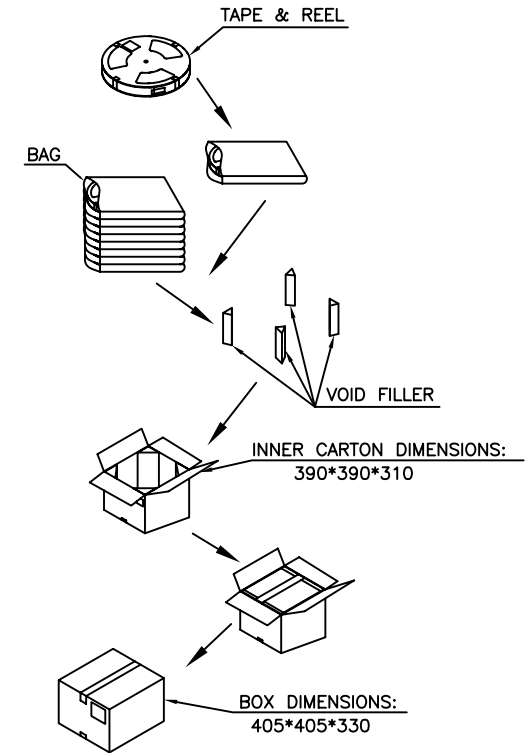
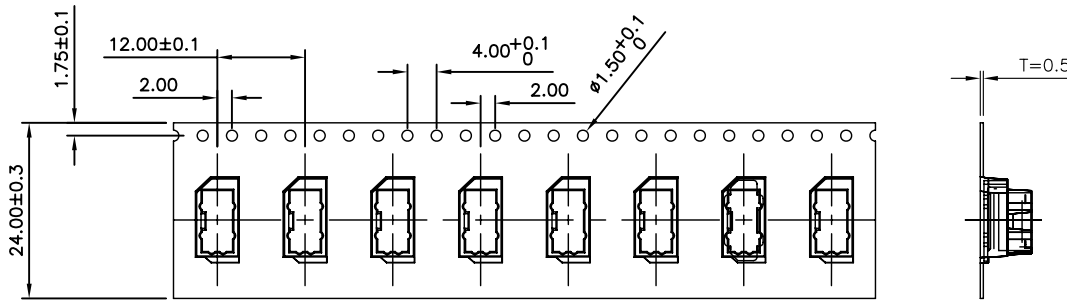
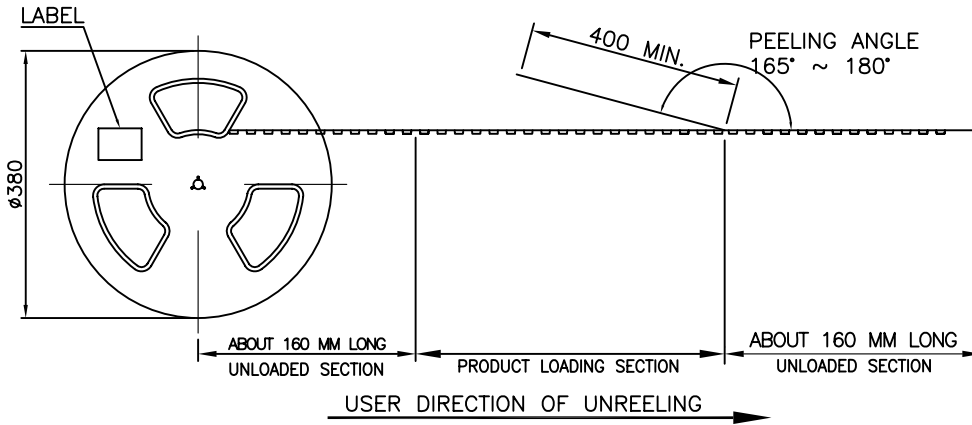

NOTE:

- MATERIAL:
BOX: FIBREBOARD, CORRUGATED, DOUBLE WALL.
TAPE: POLYSTYRENES, HEAT-RESISTANT TEMPERATURE: 120°C , BLACK COLOR.
REEL: POLYSTYRENES, HEAT-RESISTANT TEMPERATURE: 70°C , BLUE COLOR.
BAG: POLYETHYLENE, HEAT-RESISTANT TEMPERATURE: 100°C .

2. PEELING STRENGTH: $0.1 \sim 1.3 \text{ N}$ ($10 \sim 130 \text{ GRAMS}$)

3. PEELING SPEED: 300 mm/min.

4. EACH BAG SHALL BE INCLUDED DESICCANT.

1000	10	10000 PCS	-- KG	-- KG
PCS/ REEL	REELS/ CARTON	QUANTITY	GROSS WEIGHT	NET WEIGHT

Singatron Enterprise Co., Ltd.				
TITLE	MICRO USB BF VERTICAL H5.20mm waterproof IPX8			
DWN	GAORUI	PART NO. 2UB1181-61X36-22A		
CHKD	2018.05.15	SCALE 1:1	UNIT: mm	
APVD		SIZE: A3	SHEET: 3/3	REV: A
CUSTOMER COPY				

REV.	DESCRIPTION	ECN NO.	DWN.	CHK.	APVD.	DATE	TOLERANCES UNLESS OTHERWISE SPECIFIED
A	修改外形结构	201901230024	GAORUI	Chain	DC.Feng	2019.01.23	X ±0.50
T2	修改产品结构及尺寸标注	20180616001	GAORUI	Chain	DC.Feng	2018.06.16	X.X ±0.30
T1	RELEASE		GAORUI	Chain	DC.Feng	2018.05.15	X.XX ±0.20
							X.XXX ±0.10
							ANGLE ±1°