

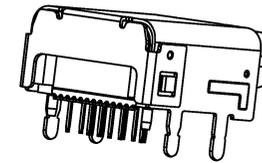

RoHS Compliant HSF
2013/95/EC

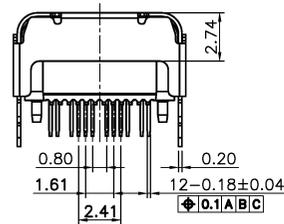
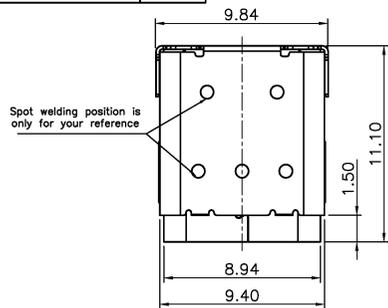

NOTES:

1.ELECTRONIC:

CONTACT CURRENT RATING: 5.0A Max
ATED VOLTAGE: 5V AC Max
CONTACT RESISTANCE: 40mohm Max
INSULATION RESISTANCE: 100 Megohms Min
WITHSTAND VOLTAGE: AC 100V,1Min.

2.MECHANICAL:

MATING FORCE: 2.04KG Max
UNMATED FORCE: 0.82KG Min
DURABILITY: 10000 CYCLES

3.ENVIRONMENT CHARACTERISTICS:

OPERTING TEMPERATURE: -25°C TO +85°C

4.PART UNMBER:

2UB1186-11XXX-23A

- 1: G/F 10:WHITE
- 2: 5u" 21:BLACK
- 3: 10u"
- 4: 15u"
- 5: 30u"

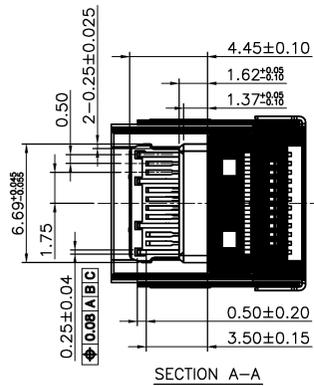
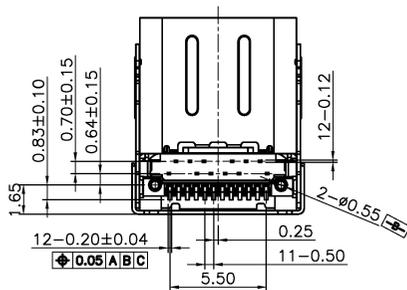
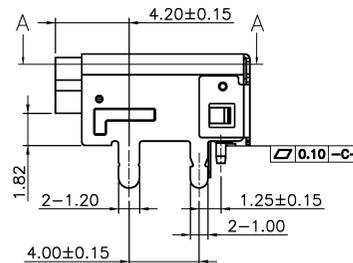
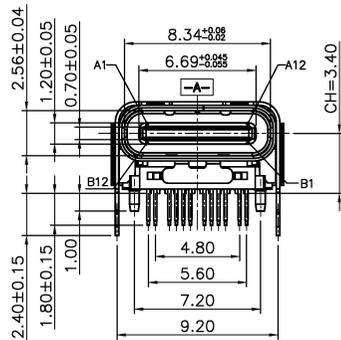

MATERIAL LIST:

No.	PART NAME	QTY	MATERIAL	REMARK
6	ENC	1	STAINLESS STEEL	NICKEL PLATED
5	MID PLATE	1	STAINLESS STEEL	-----
4	OUT SHELL	1	STAINLESS STEEL	NICKEL PLATED
3	INNER SHELL	1	STAINLESS STEEL	NICKEL PLATED
2	CONTACT	24	COPPER ALLOY	AU 3U PLATED
1	HOUSING	1	LCP	(UL94V-0) BLACK /WHITE
No.	PART NAME	QTY	MATERIAL	REMARK

TOLERANCES UNLESS OTHERWISE SPECIFIED

UNIT	(MM)
X.	±0.50
X.X	±0.30
X.XX	±0.20
X.XXX	±0.10
ANGEL	±2'

Singatron Enterprise Co., Ltd.

TITLE	USB 3.1 TYPE CF CH3.40 DIP+SMT TYPE			
DWN	YAN	PART NO.	2UB1186-11XXX-23A	
CHKD	2021.11.01	SCALE	1:1	UNIT: mm
APVD	FCC	SIZE	A3	SHEET: 1 OF 3
				REV: A

REV.	DESCRIPTION	ECN NO.	DWN.	CHK.	APVD.	DATE
A	New Product		YAN	YAN	FCC	2021.11.02

CUSTOMER COPY



RoHS Compliant
2013/95/EC HSF

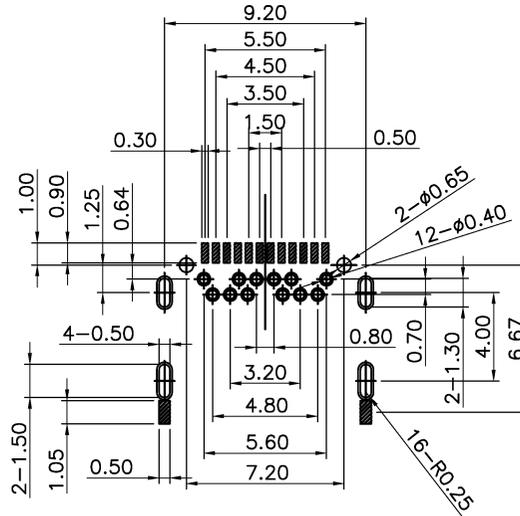

RECOMMENDED P.C.B LAYOUT(COMPANENT SIDE)

PCB THICKNESS: 2.0±0.05mm

Pin No	Signal Name	Mating Sequence	Pin No	Signal Name	Mating Sequence
A1	GND	First	B12	GND	First
A2	TX1+	Second	B11	RX1+	Second
A3	TX1-	Second	B10	RX1-	Second
A4	Vbus	First	B9	Vbus	First
A5	CC1	Second	B8	SBU2	Second
A6	D+	Second	B7	D-	Second
A7	D-	Second	B6	D+	Second
A8	SBU1	Second	B5	CC2	Second
A9	Vbus	First	B4	Vbus	First
A10	RX2-	Second	B3	TX2-	Second
A11	RX2+	Second	B2	TX2+	Second
A12	GND	First	B1	GND	First
SHELL		GND	SHELL		GND

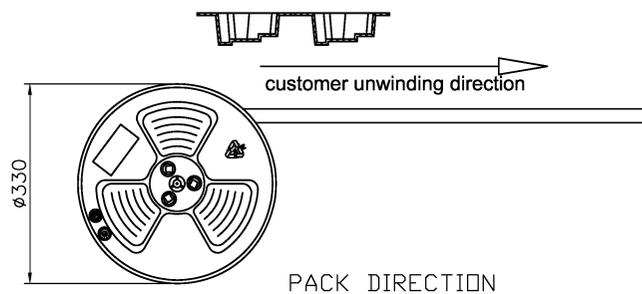
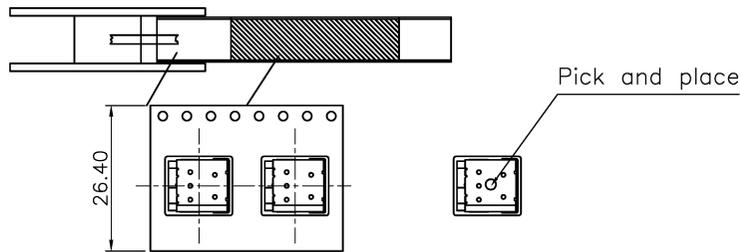

TOLERANCES UNLESS OTHERWISE SPECIFIED

UNIT	(MM)
X.	±0.50
X.X	±0.30
X.XX	±0.20
X.XXX	±0.10
ANGEL	±2°

Singatron Enterprise Co., Ltd.

TITLE	USB 3.1 TYPE CF CH3.40 DIP+SMT TYPE			
DWN	YAN	PART NO. 2UB1186-11XXX-23A		
CHKD	2021.11.02	SCALE 1:1	UNIT: mm	④
APVD	FCC	SIZE: A3	SHEET: 2 OF 3	REV: A

CUSTOMER COPY

Pb
Process
Capable
**RoHS
Compliant** HSF
2013/95/EC

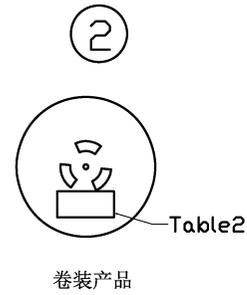
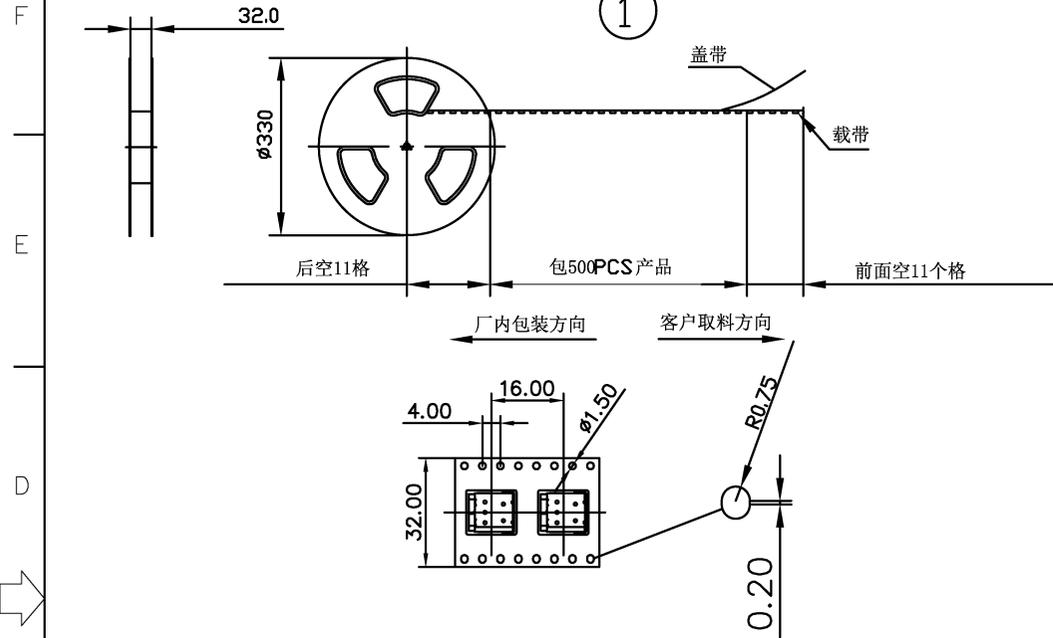

2 每卷贴上内标签 (如图所示)

3

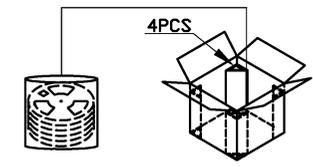

3-1. 将10盘装入PE胶袋, 再放入纸箱中。
3-2. 纸箱4个角落用缓冲材料塞好, 并盖上与之相配的纸板
备注: 纸箱的规格: 340*340*380 (mm)
PE胶袋的规格: (长) 650mm* (宽) 620mm* (厚) 0.05mm
3-3. 包装明细:

盘/每箱	PCS/每盘	PCS/每箱
10盘/每箱	500PCS/每盘	5000PCS/每箱

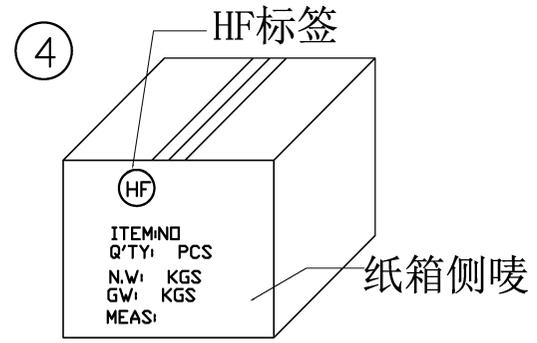

4-1 纸箱开口处以透明胶带贴合。
4-2 若有未装满的零数箱, 必须以缓冲材塞
4-3. 产品外包装标签贴法: (如上图)。

TOLERANCES UNLESS OTHERWISE SPECIFIED

UNIT	(MM)
X.	±0.50
X.X	±0.30
X.XX	±0.20
X.XXX	±0.10
ANGEL	±2'

Singatron Enterprise Co., Ltd.				
TITLE	USB 3.1 TYPE CF CH3.40 DIP+SMT TYPE			
DWN	YAN	PART NO.	2UB1186-11XXX-23A	
CHKD	2021.11.01	SCALE 1:1	UNIT: mm	④
APVD	FCC	SIZE: A3	SHEET: 3 OF 3	REV: A
CUSTOMER COPY				