

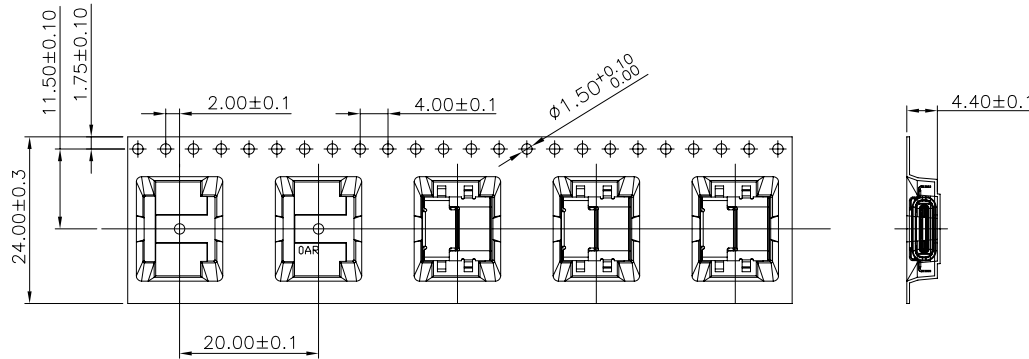

RoHS Compliant HSF
2013/95/EC

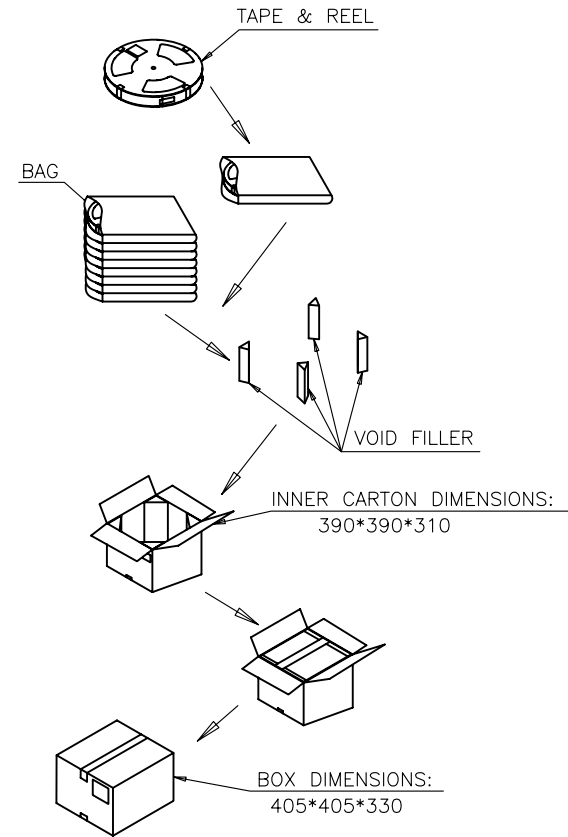
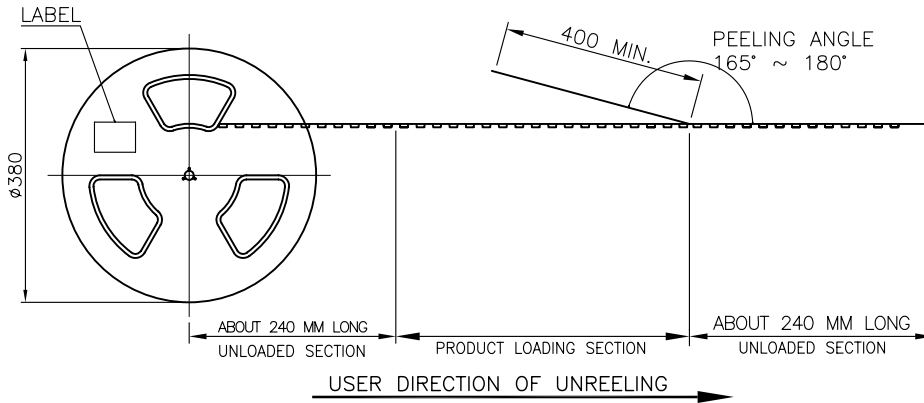
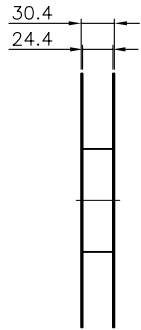

NOTE:

1.MATERIAL:

- BOX: FIBREBOARD, CORRUGATED, DOUBLE WALL.
- TAPE: POLYSTYRENES, HEAT-RESISTANT TEMPERATURE: 120°C, BLACK COLOR.
- REEL: POLYSTYRENES, HEAT-RESISTANT TEMPERATURE: 70°C, BLUE COLOR.
- BAG: POLYETHYLENE, HEAT-RESISTANT TEMPERATURE: 100°C.

2.PEELING STRENGTH: 0.1 ~ 1.3 N (10 ~ 130 GRAMS)

3.PEELING SPEED: 300 mm/min.

4.EACH BAG SHALL BE INCLUDED DESICCANT.

1000	10	10000 PCS	-- KG	-- KG
PCS/ REEL	REELS/ CARTON	QUANTITY	GROSS WEIGHT	NET WEIGHT

REV.	DESCRIPTION	ECN NO.	DWN.	CHK.	APVD.	DATE
E	ADD LASER WELDING	20180124002	Lijun	Nalson	DC	2018.01.24
D	ADD P/N	20170628001	zw-Lin	Lijun	Nalson	2017.06.28
C	MODIFY THE PRODUCT STRUCTURE	20161112001	Leiny	Chain	DC	2016.11.12
B	MODIFY THE SIZE MARKING	20161027001	Leiny	Chain	DC	2016.10.27
A	NEW DARWING	ECN NO.	Leiny	Chain	DC	2015.11.04

TOLERANCES UNLESS OTHERWISE SPECIFIED	
UNIT	(MM)
X.	±0.50
X.X	±0.30
X.XX	±0.20
X.XXX	±0.10
ANGEL	±2'

Singatron Enterprise Co., Ltd.			
TITLE	USB 3.1 C TYPE RECEPTACLE CL-0.50 H1.65mm HYBRID TYPE		
DWN	Leiny	PART NO. 2UB1186-32XXX-23A	
CHKD	2015.11.04	SCALE 1:1	UNIT: mm
APVD		SIZE: A3	SHEET: 2/2
REV: E			
CUSTOMER COPY			