

RECOMMENDED PCB LAYOUT
CONNECTOR FRONT EDGE

SPECIFICATIONS:

1. ELECTRICAL CHARACTERISTICS:
 - 1-1. RATING: 1.5A; 30V
 - 1-2. CONTACT RESISTANCE: 30mΩ MAX.
 - 1-3. INSULATION RESISTANCE: 1000MΩ MIN. @ 500V DC.
 - 1-4. DIELECTRIC WITHSTANDING VOLTAGE: 500V AC FOR 1 MINUTE.
2. MECHANICAL CHARACTERISTICS:
 - 2-1. INSERTION FORCE: 35N MAX.
 - 2-2. WITHDRAWAL FORCE: 10N MIN.
3. LIFE TEST: 5,000 CYCLES MIN.
4. OPERATING TEMPERATURE: -55°C TO +85°C.
5. OTHER GENERAL SPEC. TO REFER "2UB1560 SERIES SPEC."
6. TO CONFORM TO THE SINGATRON HAZARDOUS SUBSTANCE FREE SPEC.
7. HALOGEN FREE PRODUCT IDENTIFICATION LABEL ON PACKAGING.
8. PACKAGE: SEE "2UB1560 SERIES" PACKAGE.
9. FOR REFLOW SOLDERING LEAD-FREE PROCESS.

REV.	ECN NO.	OR DESCRIPTION	REVISED	DATE
A	PDR RELEASE		IV-C	2011.03.10
B	ECN NO:110050		IV-C	2011.05.30
C	ECN NO:140130		IV-C	2014.10.13
D	ECN NO:150009		IV-C	2015.01.28

PART NO.
2UB1560-000111F

- SUFFIX: HALOGEN FREE
- PACKAGE
- 1: TAPE AND REEL
- HOUSING COLOR
- 1: BLACK
- CONTACT PLATING
- 1: 30u" Pd/Ni AND GOLD FLASH ON CONTACT AREA, TIN ON SOLDER AREA

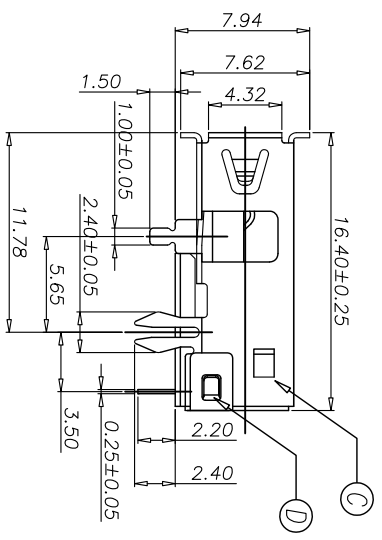
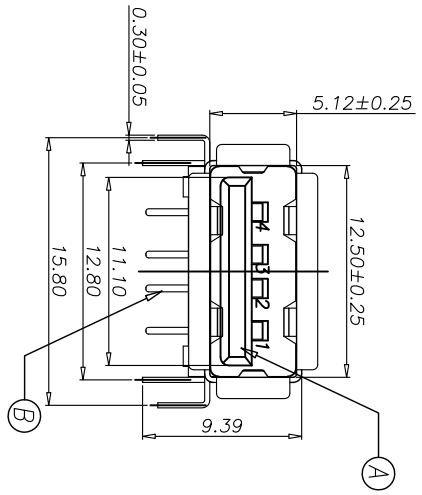

NO	DESCRIPTION	QTY	MATERIAL	PLATING & COLOR
E	INK			BLACK
D	COVER	1	STAINLESS STEEL	NICKEL PLATED
C	SHELL	1	STAINLESS STEEL	NICKEL PLATED
B	CONTACT	4	PHOSPHOR BRONZE	SEE PART NO.
A	HOUSING	1	HIGH TEMP. THERMOPLASTIC UL 94V-0	BLACK

UNLESS OTHERWISE SPECIFIED TOLERANCES

Singatron Enterprise Co., Ltd.
信亨企業股份有限公司

TITLE	USB A TYPE FEMALE, REVERSE, R/A, DIP
DRAWN	HW-C 2015.01.28
CHECKED	HW-C 2015.01.28
APVD	HW-C 2015.01.28

PART NO. **2UB1560-000111F**

SCALE 1:1 UNIT: mm

SIZE: A3 SHEET: 1 OF 1 REV: D

CUSTOMER COPY