

REV.	ECN NO OR DESCRIPTION	REVISED	DATE
A	PDR RELEASE	IVY-C	2015.02.06

SPECIFICATIONS:

- ELECTRICAL CHARACTERISTICS:
 - RATING: 1.8A (PIN1, 4); 30V.
 - CONTACT RESISTANCE: 30mΩ MAX.
 - INSULATION RESISTANCE: 1000MΩ MIN. @ 500V DC.
 - DIELECTRIC WITHSTANDING VOLTAGE: 500V AC FOR 1 MINUTE.
- MECHANICAL CHARACTERISTICS:
 - INSERTION FORCE: 3.5Kgf MAX.
 - WITHDRAWAL FORCE: 1.0Kgf MIN.
- LIFE TEST: 5,000 CYCLES MIN.
- OPERATING TEMPERATURE: -55°C TO +85°C.
- OTHER GENERAL SPEC. TO REFER "2UB1564-000211F SPEC".
- TO CONFORM TO THE SINGATRON HAZARDOUS SUBSTANCE FREE SPEC.
- HALOGEN FREE PRODUCT IDENTIFICATION LABEL ON PACKAGING: 
- PACKAGE: SEE "2UB1564-000211F" PACKAGE.
- FOR REFLOW SOLDERING LEAD-FREE PROCESS.

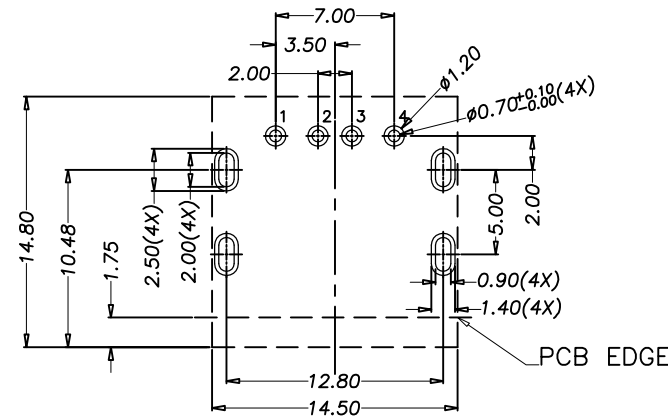

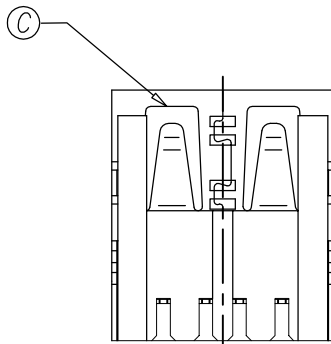
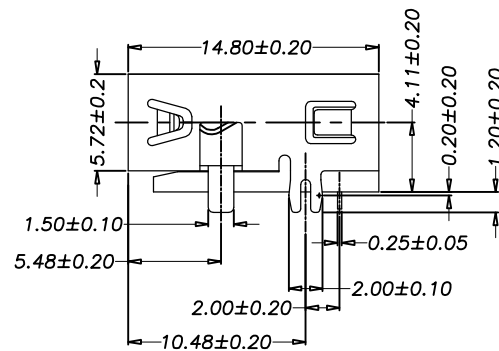
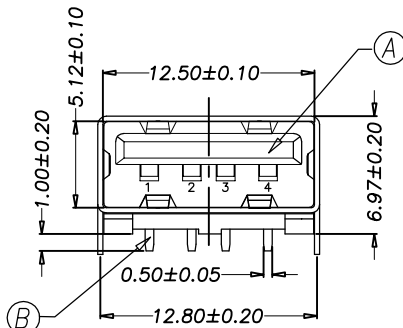
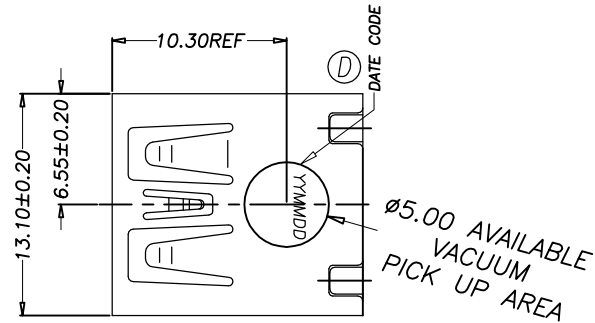

RECOMMENDED PCB LAYOUT (COMPONENT SIDE)
 TOLERANCE: ±0.05mm, PCB THICKNESS 1.20mm

PART NO.

2UB1564-000211F

- SUFFIX: HALOGEN FREE
- PACKAGE: 1: TAPE AND REEL
- HOUSING COLOR: 1: BLACK
- CONTACT PLATING: 2: 30u" GOLD ON CONTACT AREA, 120u" Sn PLATING ON SOLDER AREA, 50u" Ni UNDERPLATED OVERALL

D	INK			BLACK
C	SHELL	1	SUS301	NICKEL PLATED
B	CONTACT	4	C5191	SEE PART NO.
A	HOUSING	1	LCP, UL94V-0	BLACK
NO	DESCRIPTION	QTY	MATERIAL	PLATING & COLOR
UNLESS OTHERWISE SPECIFIED TOLERANCES		 Singatron Enterprise Co., Ltd.  信音企業股份有限公司		
DECIMALS:	ANGLES:	TITLE	USB A TYPE FEMALE, R/A, DIP	
X : ±0.5	X : ±2°	DWN	IVY-C 2015.02.06	PART NO. 2UB1564-000211F
X.X : ±0.3	X.X : ±1°	CHKD	ANGELA 2015.02.06	SCALE 1:1 UNIT: mm
X.XX : ±0.2		APVD	ANGELA 2015.02.06	SIZE: A3 SHEET: 1 OF 1 REV: A
CUSTOMER COPY				