

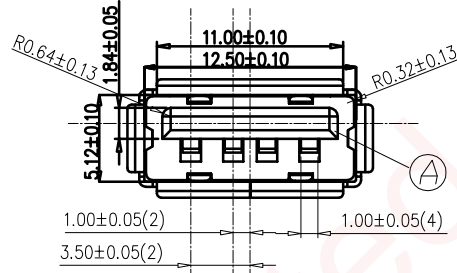

REV.	ECN NO OR DESCRIPTION	REVISED	DATE
A	PDR RELEASE	IVY-C	2015.10.23

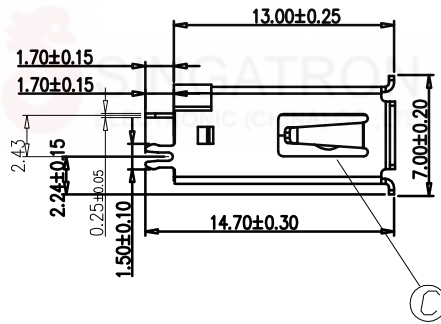

- ELECTRICAL CHARACTERISTICS:
  - RATING: 1.5A; 30V.
  - CONTACT RESISTANCE: 30mΩ MAX.
  - INSULATION RESISTANCE: 1000MΩ MIN. @ 500V DC.
  - DIELECTRIC WITHSTANDING VOLTAGE: 500V AC FOR 1 MINUTE.
- MECHANICAL CHARACTERISTICS:
  - INSERTION FORCE: 35N MAX.
  - WITHDRAWAL FORCE: 10N MIN.
- LIFE TEST: 5000 CYCLES MIN.
- OPERATING TEMPERATURE: -55°C TO +85°C.
- OTHER GENERAL SPEC. TO REFER "2UB1600-110112F SPEC".
- TO CONFORM TO THE SINGATRON HAZARDOUS SUBSTANCE FREE SPEC.
- HALOGEN FREE PRODUCT IDENTIFICATION LABEL ON PACKAGING: 
- PACKAGE: SEE "2UB1600-110112F" PACKAGE.
- FOR REFLOW SOLDERING LEAD-FREE PROCESS.

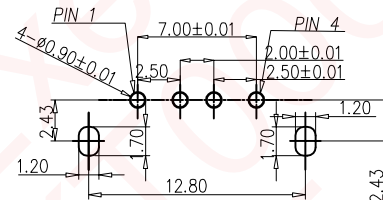
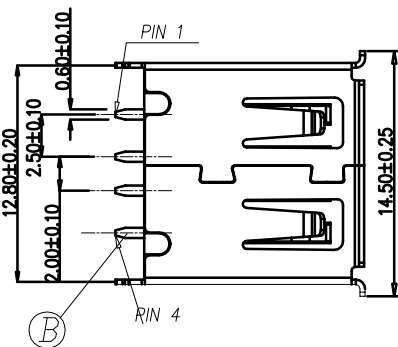

PCBLayout

PART NO.

2UB1600-110112F



CONTACT&SHELL TALL LENGTH  
1: 1.70mm

CAP  
1: WITH CAP

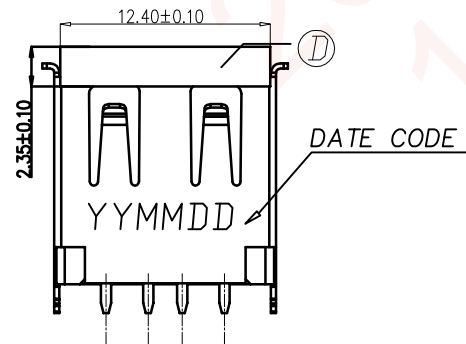
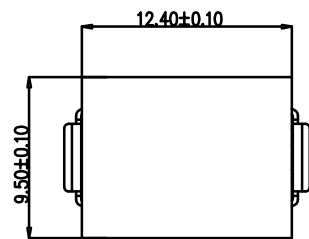
SUFFIX: HALOGEN FREE  
PACKAGE  
1: TAPE&REEL  
HOUSING COLOR  
1: BLACK  
CONTACT PLATING  
1: GOLD FLASH PLATING ON CONTACT AREA,  
50U" MIN TIN PLATING ON SOLDER AREA  
50U" MIN NICKEL UNDERPLATED OVERALL



WITH CAP

D	CAP	1	LCP UL 94V-0	BLACK
C	SHELL	1	SUS 304	50u" MIN NICKEL PLATED
B	CONTACT	4	C2680-H	SEE PART NO.
A	HOUSING	1	LCP UL 94V-0	BLACK
NO	DESCRIPTION	QTY	MATERIAL	PLATING & COLOR
UNLESS OTHERWISE SPECIFIED TOLERANCES			 Singatron Enterprise Co., Ltd.  信音企業股份有限公司	
DECIMALS:		ANGLES:		
X	: ±0.5	X	: ±2°	
X.X	: ±0.3	X.X	: ±1°	
X.XX	: ±0.2			
TITLE	USB2.0 A TYPE FEMALE, VERTICAL, DIP TYPE			
DWN	IVY-C 2015.10.23	PART NO. 2UB1600-110112F		
CHKD	ANGELA2015.10.23	SCALE 3.3:1	UNIT: mm	
APVD	ANGELA2015.10.23	SIZE: A3	SHEET: 1 OF 1	REV: A

CUSTOMER COPY