

RECOMMENDED P.C.B. LAYOUT  
DEFAULT TOLERANCE: ±0.05

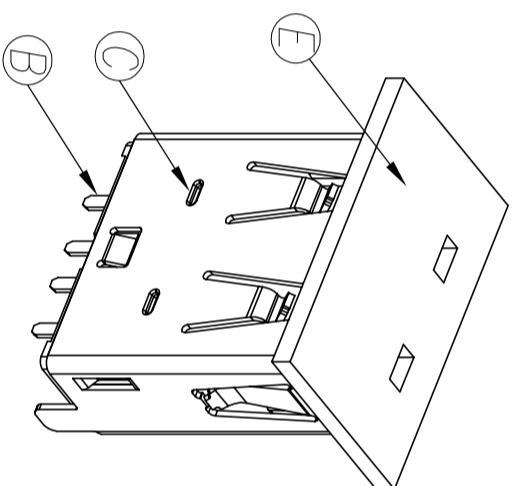

SPECIFICATIONS:

- ELECTRICAL CHARACTERISTICS:
  - CURRENT RATING: 1.8A
  - VOLTAGE RATING: 30V
  - CONTACT RESISTANCE: 30mΩ MAX.
  - DIELECTRIC WITHSTANDING VOLTAGE: 500V AC FOR ONE MINUTE
  - INSULATION RESISTANCE: 1000MΩ MIN. (500V DC)
- MECHANICAL CHARACTERISTICS:
  - INSERTION FORCE: 35N MAX.
  - UNMATING FORCE: 10N MIN.(INITIAL), 8N MIN.(AFTER LIFE TEST)
  - LIFE TEST: 1500 CYCLES.
- OPERATING TEMPERATURE : -40°C TO +85°C
- OTHER GENERAL SPEC. TO REFER "2UB1600-211212F SPEC".
- TO CONFORM TO SINGATRON HAZARDOUS SUBSTANCE FREE SPEC.
- HALOGEN FREE PRODUCT IDENTIFICATION LABEL ON PACKAGING:
- PACKAGING: TAPE & REEL.

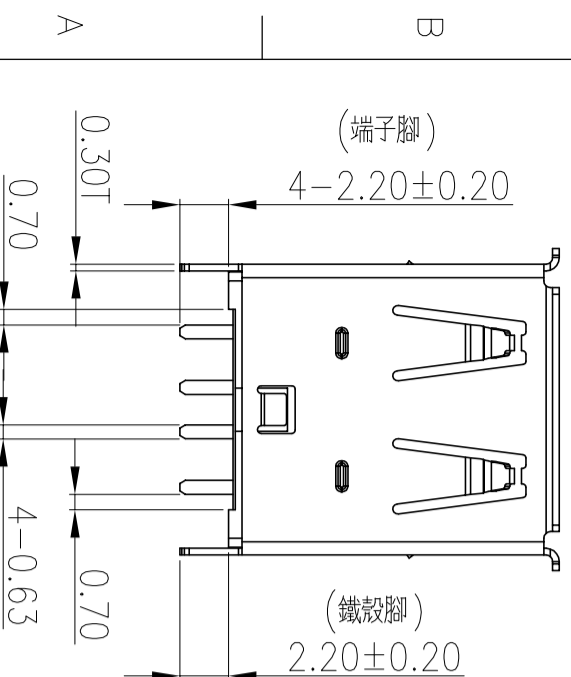
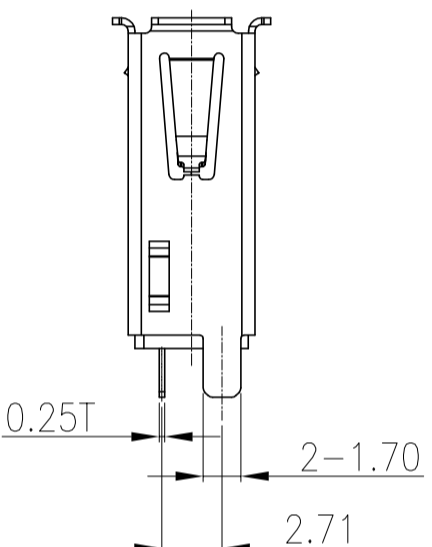
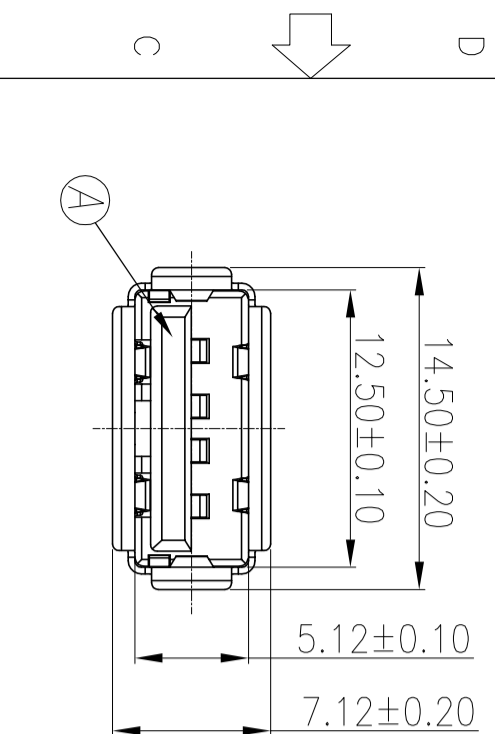
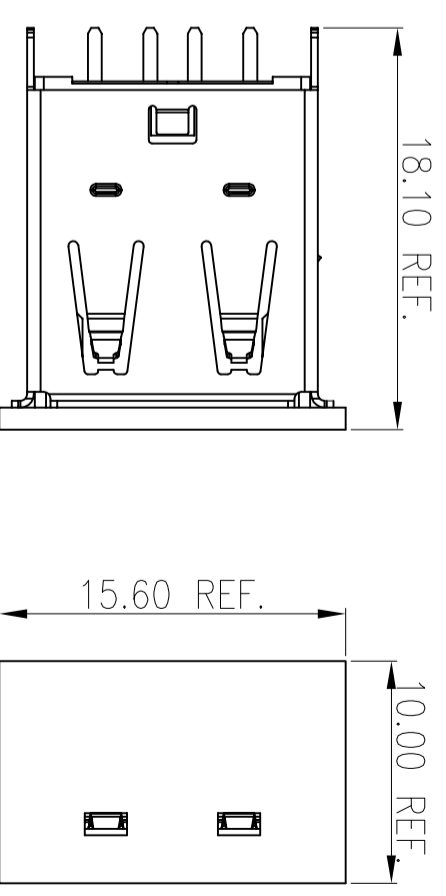

ASSEMBLY CAP SCHEMATIC

NO.	DESCRIPTION	QTY	MATERIAL	PLATING & COLOR
E	CAP	1	HIGH TEMPERATURE PLASTIC UL94V-0	BLACK
D	COVER	1	HIGH TEMPERATURE PLASTIC UL94V-0	BLACK
C	SHELL	1	BRASS T=0.30mm	NICKEL PLATING
B	CONTACT	4	BRASS T=0.25mm	GOLD FLASH ON CONTACT AREA MATTE TIN ON SOLDER AREA NICKEL UNDERPLATED OVERALL
A	HOUSING	1	HIGH TEMPERATURE PLASTIC UL94V-0	BLACK

UNLESS OTHERWISE SPECIFIED TOLERANCES

Singatron Enterprise Co., Ltd.  
**信音企業股份有限公司**

DECIMALS:	ANGLES:	TITLE	UNIT	REV.
X : ±0.5	X : ±2°	USB2.0 A TYPE FEMALE, VERTICAL, DIP TYPE	mm	A
X.X : ±0.3	X.X : ±1°	PART NO.: 2UB1600-211212F	mm	
X.XX : ±0.2		SCALE 1:1	mm	
		SIZE: A3	SHEET: 10F1	

CUSTOMER COPY