

REV.	ECN NO OR DESCRIPTION	REVISED	DATE
A	PDR RELEASE	IVY-C	2015.10.06

SPECIFICATIONS:

- ELECTRICAL CHARACTERISTICS:
 - RATING: 1.8A; 30V.
 - CONTACT RESISTANCE: 30mΩ MAX.
 - INSULATION RESISTANCE: 1000MΩ MIN. @ 500V DC.
 - DIELECTRIC WITHSTANDING VOLTAGE: 500V AC FOR 1 MINUTE.
- MECHANICAL CHARACTERISTICS:
 - INSERTION FORCE: 35N MAX.
 - WITHDRAWAL FORCE: 10~35N Min.
- LIFE TEST: 5,000 CYCLES.
- TEMPERATURE RANGE: -40°C TO +85°C.
- OTHER GENERAL SPEC. TO REFER "2UB1624-020111F SPEC".
- TO CONFORM TO THE SINGATRON HAZARDOUS SUBSTANCE FREE SPEC.
- HALOGEN FREE PRODUCT IDENTIFICATION LABEL ON PACKAGING: 
- PACKAGE: SEE "2UB1624-020111F" PACKAGE.
- FOR REFLOW SOLDERING LEAD-FREE PROCESS.

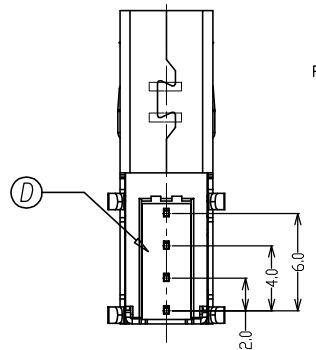
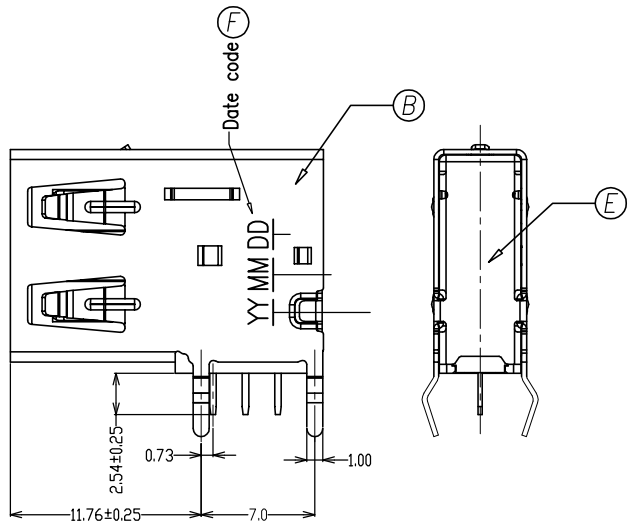
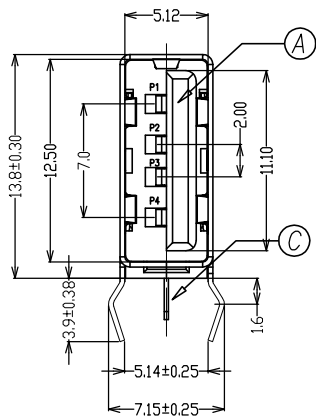
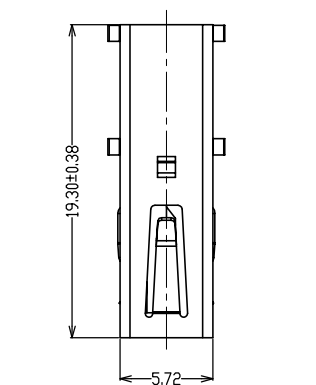

PROFILE OF CONECTOR

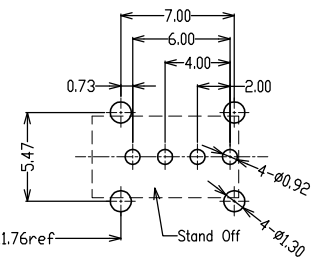

PCB LAYOUT(TOP VIEW)
TOLERANCE:±0.05mm

2UB1624-020111F

- SUFFIX: HALOGEN FREE
- PACKAGE: 1: TRAY
- HOUSING COLOR: 1: BLACK
- CONTACT PLATING: 1: 30u" Au PLATING ON CONTACT AREA, 100u"Min. TIN(Sn) PLATING ON SOLDER AREA, 50u"Min. Ni UNDERPLATING OVERALL

F	INK	-	INK	BLACK
E	REAR SHELL	1	SPCC	50u"Min. Ni PLATED
D	COVER	1	LCP, UL94-V0	BLACK
C	CONTACT	4	COPPER ALLOY	SEE PART NO.
B	SHELL	1	STAINLESS STEEL	50u"Min. Ni PLATED
A	HOUSING	1	LCP, UL94-V0	BLACK
NO	DESCRIPTION	QTY	MATERIAL	PLATING & COLOR

UNLESS OTHERWISE SPECIFIED TOLERANCES

 Singatron Enterprise Co., Ltd.
信音企業股份有限公司

DECIMALS:	ANGLES:	TITLE	USB2.0 A TYPE FEMALE, DIP, VERTICAL, H=13.80mm	
X :±0.5	X :±2°	DWN	IVY-C 2015.10.06	PART NO. 2UB1624-020111F
X.X :±0.3	X.X :±1°	CHKD	ANGELA 2015.10.06	SCALE:3.3:1 UNIT: mm
X.XX :±0.2		APVD	ANGELA 2015.10.06	SIZE: A3 SHEET:1 OF 1 REV: A

CUSTOMER COPY