

REV.	ECN NO OR DESCRIPTION	REVISED	DATE
A	PDR RELEASE	EVEN	2020.02.21

- SPECIFICATIONS:
- ELECTRICAL CHARACTERISTICS:
    - CURRENT RATING: 1.8A (PIN1,4) ; OTHER CONTACTS 0.25A
    - CONTACT RESISTANCE: 30mΩ MAX INITIAL FOR PIN1~4  
50mΩ MAX INITIAL FOR OTHER PIN.
    - DIELECTRIC WITHSTANDING VOLTAGE: 100V AC FOR 1 MINUTE
    - INSULATION RESISTANCE: 100MΩ MIN
  - MECHANICAL CHARACTERISTICS:
    - INSERTION FORCE : 3.5 Kgf MAX
    - WITHDRAWAL FORCE : 1.0~3.5 Kgf (INITIAL),  
0.8~3.5 Kgf (AFTER TEST LIFE).
  - DURABILITY: 5,000 CYCLES,
  - TO CONFORM TO SINGATRON HAZARDOUS SUBSTANCE FREE SPEC.
  - HALOGEN FREE PRODUCT IDENTIFICATION LABEL ON PACKAGING: 
  - FOR REFLOW SOLDERING LEAD-FREE PROCESS.
  - PACKAGING : TAPE & REEL. SEE "2UB1646-003X11F" PACKAGE.
  - OTHER GENERAL SPEC. TO REFER "2UB1646-003X11F SPEC".

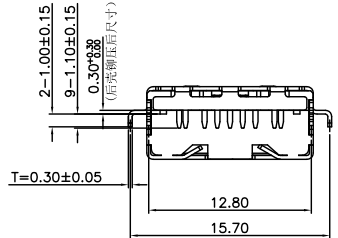
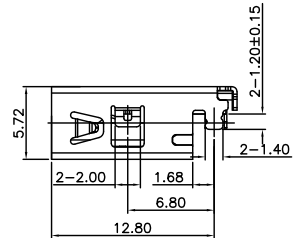
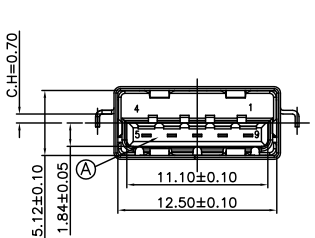
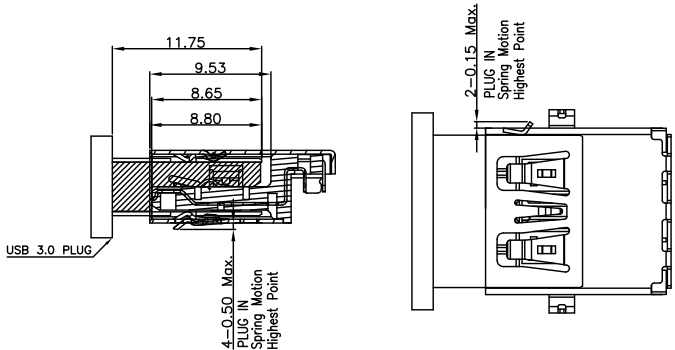
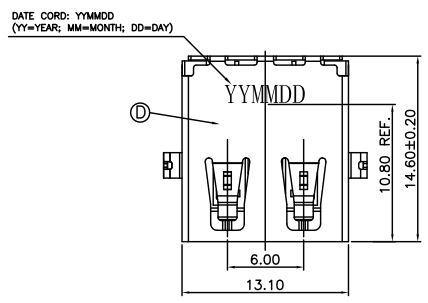

PART NO. 2UB1646-003X11F

- SUFFIX: HALOGEN FREE
- PACKAGE: TAPE & REEL
- HOUSING COLOR: BLACK
- CONTACT PLATING:
  - 30u" GOLD ON CONTACT AREA, MATTE TIN 80u"MIN. ON SOLDER TAIL ALL OVER 50u"MIN. NICKEL PLATED
  - GOLD FLASH ON CONTACT AREA, MATTE TIN 80u"MIN. ON SOLDER TAIL ALL OVER 50u"MIN. NICKEL PLATED

Pin Number	Signal ASSIGNMENT
PIN 1	VBUS
PIN 2	D-
PIN 3	D+
PIN 4	GND
PIN 5	StdA_SSRX-
PIN 6	StdA_SSRX+
PIN 7	GND_DRAIN
PIN 8	StdA_SSTX-
PIN 9	StdA_SSTX+

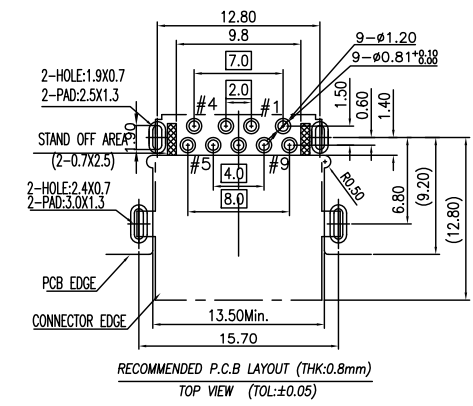
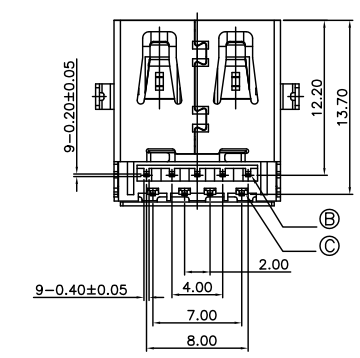
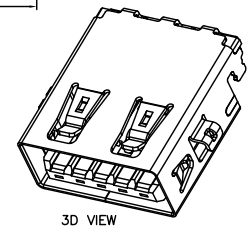

NO	DESCRIPTION	QTY	MATERIAL	PLATING & COLOR
D	SHELL	1	SUS304 0.3T	NICKEL 50u"MIN
C	4P TERMINAL	4	C5210-EH 0.2T	GOLD FLASH ON CONTACT AREA, MATTE TIN 80u"MIN. ON SOLDER TAIL ALL OVER 50u"MIN. NICKEL PLATED
B	5P TERMINAL	5	C2680-EH 0.2T	ALL OVER 50u"MIN. NICKEL PLATED
A	HOUSING	1	LCP E130i UL94-V0	BLACK

UNLESS OTHERWISE SPECIFIED TOLERANCES

 Singatron Enterprise Co., Ltd.  
信音企業股份有限公司

DECIMALS: ANGLES: TITLE: USB 3.0 CONNECTOR

X :±0.5 X :±2° DWN EVEN 2020.02.21 PART NO. 2UB1646-003X11F

X.X :±0.3 X.X :±1° CHKD SCALE 4:1 UNIT: mm

X.XX :±0.2 APVD ANGEL 2020.02.21 SIZE: A3 SHEET: 1 OF 1 REV: A

CUSTOMER COPY