

REV.	ECN NO OR DESCRIPTION	REVISED	DATE
A	PDR RELEASE	IVY-C	2015.12.04

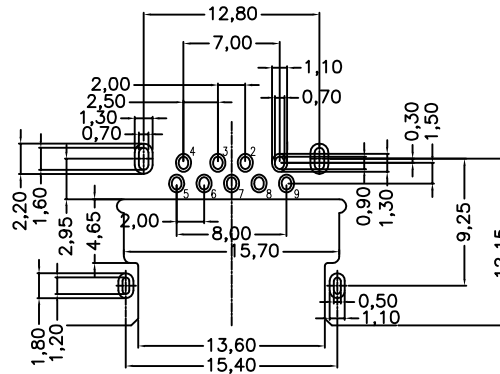
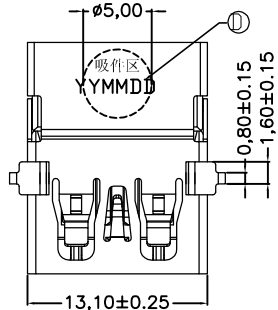

RECOMMEND P.C.B LAYOUT (TOLERANCES ±0.05mm)  
(COMPONENT SIDE) THICKNESS=1.2mm

SPECIFICATIONS:

- ELECTRICAL CHARACTERISTICS:
  - CURRENT RATING: 1.8A (PIN1,4) ; OTHER CONTACTS 0.25A.
  - CONTACT RESISTANCE: 30mΩ MAX.
  - INSULATION RESISTANCE: 100MΩ MIN. @ 100V DC.
  - DIELECTRIC WITHSTANDING VOLTAGE: 100V AC FOR 1 MINUTE.
- MECHANICAL CHARACTERISTICS:
  - INSERTION FORCE: 25N MAXIMUM INITIAL AND AFTER TEST.
  - WITHDRAWAL FORCE: 10N ~ 25N. INITIAL, AND 8N~25N AFTER TEST
- LIFE TEST: 5000 CYCLES.
- TO CONFORM TO THE SINGATRON HAZARDOUS SUBSTANCE FREE SPEC.
- HALOGEN FREE PRODUCT IDENTIFICATION LABEL ON PACKAGING:
- PACKAGE: SEE "2UB1669 SERIES" PACKAGE.
- FOR REFLOW SOLDERING LEAD-FREE PROCESS.
- OTHER GENERAL SPEC. TO REFER "2UB1669-000111F SPEC".

PART NO.

2UB1669-000111F

- SUFFIX: HALOGEN FREE
- PACKAGE: 1: TAPE & REEL
- HOUSING COLOR: 1: BLACK
- CONTACT PLATING: 1: GOLD FLASH ON CONTACT AREA, 120u" Sn PLATING ON SOLDER AREA, 80u" Ni UNDERPLATING OVERALL

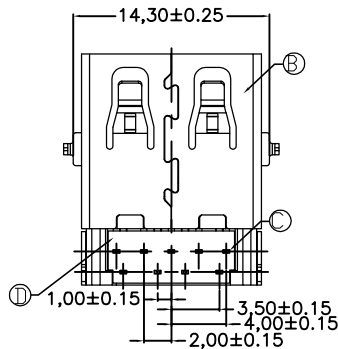
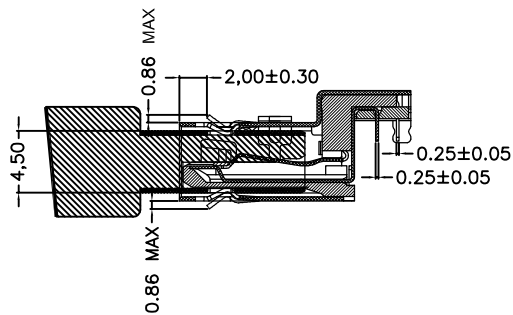
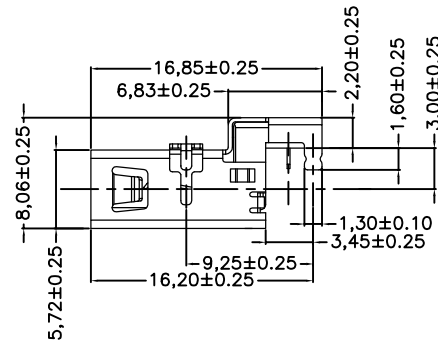
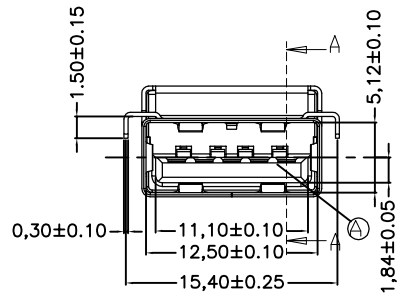

NO	DESCRIPTION	QTY	MATERIAL	PLATING & COLOR
D	COVER	1	LCP UL 94V-0	BLACK
C	CONTACT	9	C2680	SEE PART NO.
B	SHELL	1	SUS	NICKEL PLATED
A	HOUSING	1	LCP UL 94V-0	BLACK
UNLESS OTHERWISE SPECIFIED TOLERANCES		Singatron Enterprise Co., Ltd. 信音企業股份有限公司		
DECIMALS: X :±0.5 X.X :±0.3 X.XX :±0.2		ANGLES: X :±2° X.X :±1'		TITLE: USB 3.0 A TYPE FEMALE, R/A, DIP, SINKING DWN: MY-C 2015.12.04 PART NO. 2UB1669-000111F CHKD: ANGELA2015.12.04 SCALE: 1:1 UNIT: mm APVD: ANGELA2015.12.04 SIZE: A3 SHEET: 1 OF 1 REV: A
CUSTOMER COPY				