

REV.	ECN NO OR DESCRIPTION	REVISED	DATE
A	PDR RELEASE	Even	2018.02.21



SPECIFICATIONS:

- ELECTRICAL CHARACTERISTICS:
  - CURRENT RATING: 5.0A
  - VOLTAGE RATING: 20.0 V
  - LLCR: VBUS & GND PINS: 40mΩ/PIN MAX  
OTHER PINS : 40mΩ/PIN MAX  
LLCR MAX. CHANGE OF ALL PINS: 10mΩ
  - INSULATION RESISTANCE: 100MΩ MIN
- MECHANICAL CHARACTERISTICS:
  - INSERTION FORCE: 0.5~2.0kg.
  - WITHDRAWAL FORCE: 0.8~2.0kg.(INITIAL) 0.6~2.0kg.(AFTER LIFE TEST)
- DURABILITY: 10,000 CYCLES.
- TO CONFORM TO THE SINGATRON HAZARDOUS SUBSTANCE FREE SPEC.
- HALOGEN FREE PRODUCT IDENTIFICATION LABEL ON PACKAGING: 
- PACKAGE: SEE "2UB1739-C00111F" PACKAGE.
- FOR REFLOW SOLDERING LEAD-FREE PROCESS.
- OTHER GENERAL SPEC. TO REFER "2UB1739-C00111F SPEC".

PART NO. 2UB1739-C00111F

- SUFFIX: HALOGEN FREE
- PACKAGE: 1: TAPE & REEL
- HOUSING COLOR: 1: BLACK
- CONTACT PLATING: 1: 30u" Au PLATING ON MATING AREA, MATTE Sn 60u" Min. ON SOLDERING AREA, 80u" Min. NICKEL UNDER PLATING OVERALL

F	RFI PAD	2	SUS 304	NICKEL
E	TERMINAL	24	C19400	SEE PART NO.
D	SIGNAL	1	SUS 301	NICKEL
C	HOUSING	1	PA9T UL 94V-0	BLACK
B	INNER SHELL	1	SUS 301	NICKEL PLATED 50u" MIN.
A	OUTSIDE SHELL	1	SUS 301	NICKEL PLATED 50u" MIN.
NO	DESCRIPTION	QTY	MATERIAL	PLATING & COLOR

UNLESS OTHERWISE SPECIFIED TOLERANCES		 Singatron Enterprise Co., Ltd.  信音企業股份有限公司	
DECIMALS:	ANGLES:	TITLE	USB TYPE C , Mid-mount(CH=0mm)
X :±0.5	X :±2°	DWN	EVEN 2018.02.21 PART NO. 2UB1739-C00111F
X.X :±0.3	X.X :±1°	CHKD	ANGELA 2018.02.21 SCALE 1:1 UNIT: mm
X.XX :±0.2		APVD	ANGELA 2018.02.21 SIZE: A3 SHEET: 1 OF 1 REV: A

CUSTOMER COPY

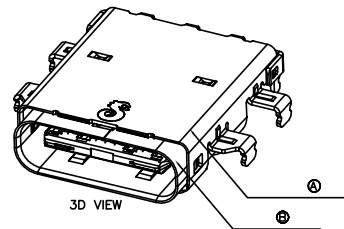
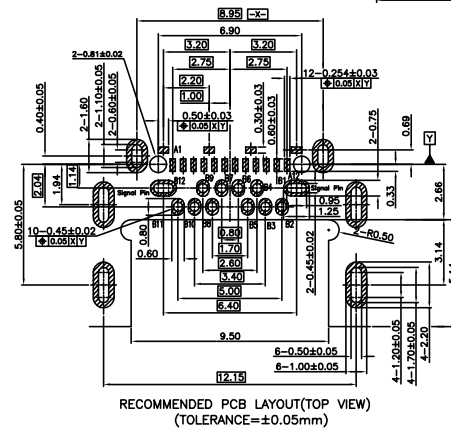
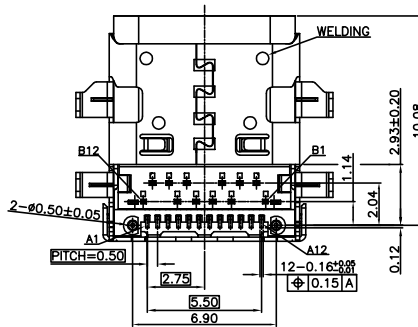
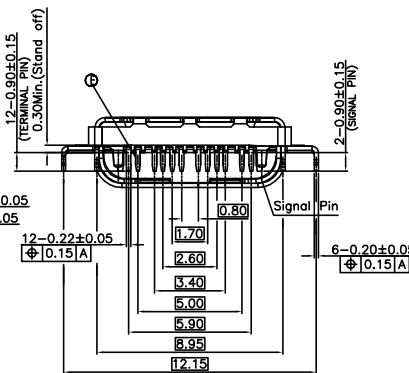
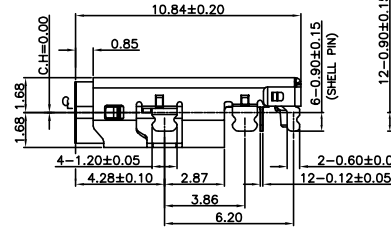
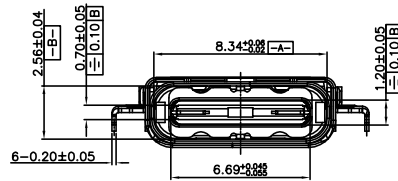
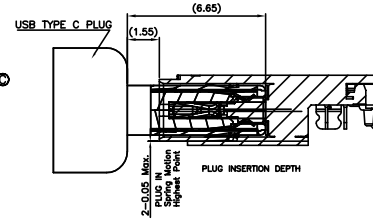
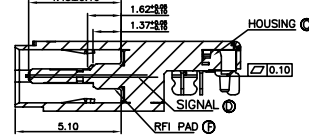
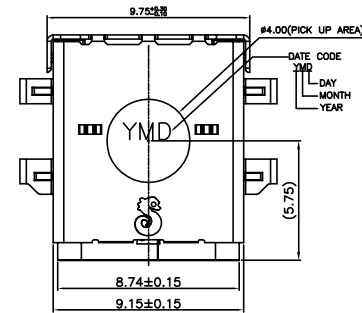

1

2

3

4

5

6

7

8