

REV.	ECN NO OR DESCRIPTION	REVISED	DATE
A	PDR RELEASE	Even	2024.01.23

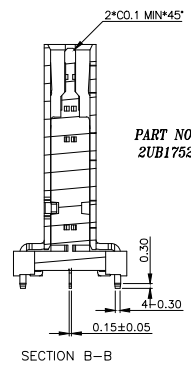
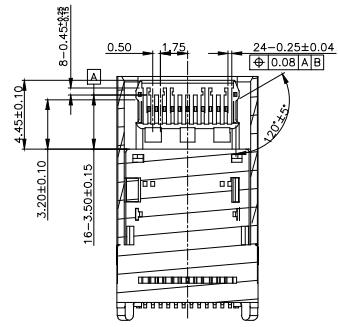
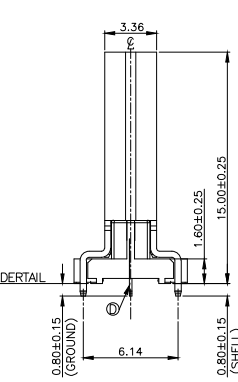
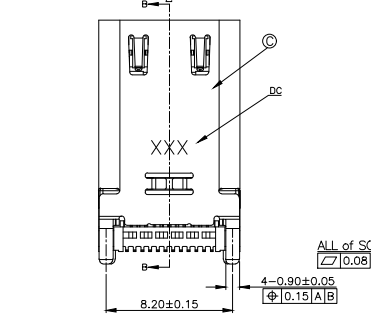
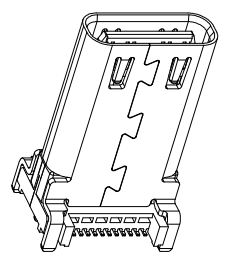
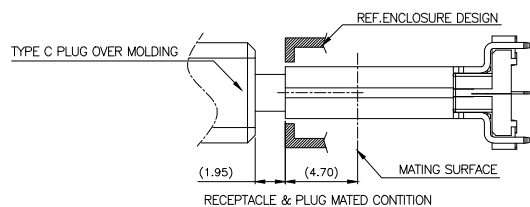
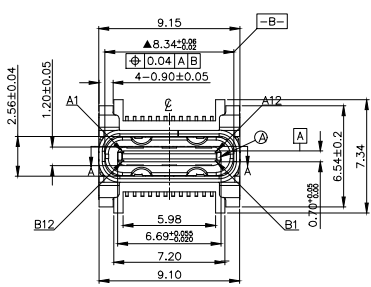

PART NO.
2UB1752-C10411F

- SUFFIX: HALOGEN FREE
- PACKAGE: TAPE & REEL
- HOUSING COLOR: 1: BLACK
- CONTACT PLATING

4: 30u" Au PLATING ON MATING AREA,
MATTE SN 60u" MIN. ON SOLDERING AREA,
80u" Min. NICKEL UNDER PLATING OVERALL

USB TYPE-C PIN ASSIGNMENTS:

A12	GND	B1	GND
A11	SSRxp2	B2	SSTxp2
A10	SSRXn2	B3	SSTXn2
A9	VBUS	B4	VBUS
A8	SBU1	B5	CC2
A7	Dn1	B6	Dp2
A6	Dp1	B7	Dn2
A5	CC1	B8	SBU2
A4	VBUS	B9	VBUS
A3	SSTXn1	B10	SSRXn1
A2	SSTxp1	B11	SSRXp1
A1	GND	B12	GND
PIN	SIGNAL NAME	PIN	SIGNAL NAME

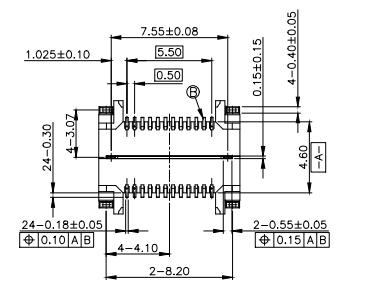

PCB SURFACE

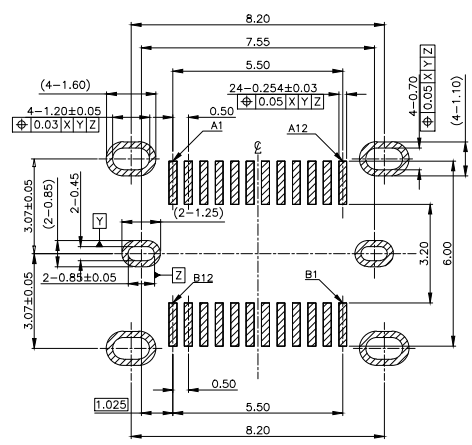

RECOMMENDED PCB LAYOUT
TOP VIEW
SCALE 2:1
(TOLERANCE=±0.05mm)

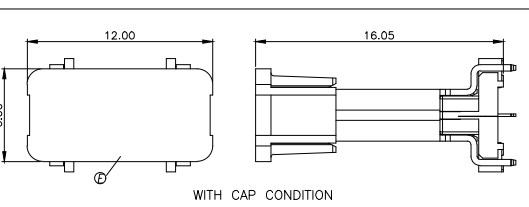

SPECIFICATIONS:

- ELECTRICAL CHARACTERISTICS:
 - CURRENT RATING: 5.0A
 - VOLTAGE RATING: 20.0 V
 - LLCR: VBUS & GND PINS: 40mΩ/PIN MAX
OTHER PINS: 40mΩ/PIN MAX
LLCR MAX. CHANGE OF ALL PINS: 10mΩ
 - INSULATION RESISTANCE: 100MΩ MIN
- MECHANICAL CHARACTERISTICS:
 - INSERTION FORCE: 0.5~2.0kg.
 - WITHDRAWAL FORCE: 1.4~2.0kg.(INITIAL:30 CYCLES),0.8~2.0kg.(AFTER LIFE TEST)
- DURABILITY: 10,000 CYCLES.
- TO CONFORM TO THE SINGATRON HAZARDOUS SUBSTANCE FREE SPEC.
- HALOGEN FREE PRODUCT IDENTIFICATION LABEL ON PACKAGING: (S)
- PACKAGE: SEE "2UB1752-C10411F" PACKAGE.
- FOR REFLOW SOLDERING LEAD-FREE PROCESS.
- OTHER GENERAL SPEC. TO REFER "2UB1752-C10411F SPEC".
- HIGH FREQUENCY: Accord with USB 3.1 GEN2 (10/gbds)Specs

E	CAP	1	LCP UL 94V-0	BLACK
D	SIGNAL	1	SUS 301	
C	SHELL	1	SUS 304	50u"MIN. NICKEL
B	CONTACT	24	C19400-H	SEE"PART NO."
A	HOUSING	1	PA9T UL 94V-0	BLACK
NO	DESCRIPTION	QTY	MATERIAL	PLATING & COLOR

UNLESS OTHERWISE SPECIFIED TOLERANCES

Singatron Enterprise Co., Ltd.
信音企業股份有限公司

DECIMALS:	ANGLES:	TITLE	USB TYPE C VERTICAL	
X :±0.5	X :±2°	DWN	REV 2024.01.23	PART NO. 2UB1752-C10411F
X.X :±0.25	X.X :±1°	CHKD	SCALE 4:1	UNIT: mm
X.XX :±0.15		APVD	TERESA2024.01.23	SIZE: A3 SHEET:1 OF 1 REV: A

CUSTOMER COPY