

REV.	ECN NO OR DESCRIPTION	REVISED	DATE
A	PDR RELEASE	EVEN	2020.10.29
B	ECN NO.L202012-C07	EVEN	2021.03.03

- SPECIFICATIONS:
- ELECTRICAL CHARACTERISTICS:
 - RATING: 5V 5A MIN FOR VBUS;0.25A MIN FOR OTHER.
 - CONTACT RESISTANCE: INITIAL 40mΩ MAX.AFTER 50mΩ MAX.
 - DIELECTRIC WITHSTANDING VOLTAGE: 500V AC FOR ONE MINUTE
 - INSULATION RESISTANCE: 1000MΩ MIN. MEASURED BY 500 VAC
 - MECHANICAL CHARACTERISTICS:
 - INSERTION FORCE : 5~20N.
 - WITHDRAWAL FORCE :8~20N(INITIAL),6~20N(AFTER 10000 CYCLES);
 - LIFE TEST: 10000 CYCLES .
 - OTHER GENERAL SPEC. TO REFER "2UB1783-CW1111F SPEC".
 - TO CONFORM TO SINGATRON HAZARDOUS SUBSTANCE FREE SPECIFICATION
 - HALOGEN FREE PRODUCT IDENTIFICATION LOGO ON PACKAGING: 
 - PACKAGE: SEE "2UB1783-CW1111F" PACKAGE.
 - FOR REFLOW SOLDERING LEAD-FREE PROCESS.

PART NO.
2UB1783-CW1111F

- 1: WITH O-RING
- SUFFIX: HALOGEN FREE
 - PACKAGE: 1: TAPE & REEL
 - HOUSING COLOR: 1: BLACK
 - CONTACT PLATING

1: 1u"MIN. Au ON MATING AREA,
1u"MIN. Au ON SOLDER AREA
30u" MIN. NICKEL UNDER PLATING OVERALL

I	O-RING	1	EPOXY	BLACK
H	GLUE WATER	1	EPOXY	BLACK
G	SHELL-B	1	SUS304	40u"MIN.NICKEL
F	SHELL-A	1	SUS316	40u"MIN.NICKEL
E	GND PLATE	1	SUS304	40u"MIN.NICKEL
D	MID PLATE	1	SUS301	GOLD FLASH
C	TERMINAL-B	12	NKE012	SEE PART NO.
B	TERMINAL-A	12	NKE012	SEE PART NO.
A	HOUSING	1	PA-46 UL 94V-0	BLACK
NO	DESCRIPTION	QTY	MATERIAL	PLATING & COLOR

UNLESS OTHERWISE SPECIFIED TOLERANCES

 信音科技(香港)有限公司

DECIMALS:	ANGLES:	TITLE	USB TYPE C ,DIP TYPE(WATERPROOF)		
X :±0.5	X :±2°	DWN	EVEN 2021.03.03	PART NO. 2UB1783-CW1111F	
X.X :±0.3	X.X :±1°	CHKD		SCALE 1:1	UNIT: mm
X.XX :±0.2		APVD	WNGELA2021.03.03	SIZE: A3	SHEET:1 OF 3

CUSTOMER COPY

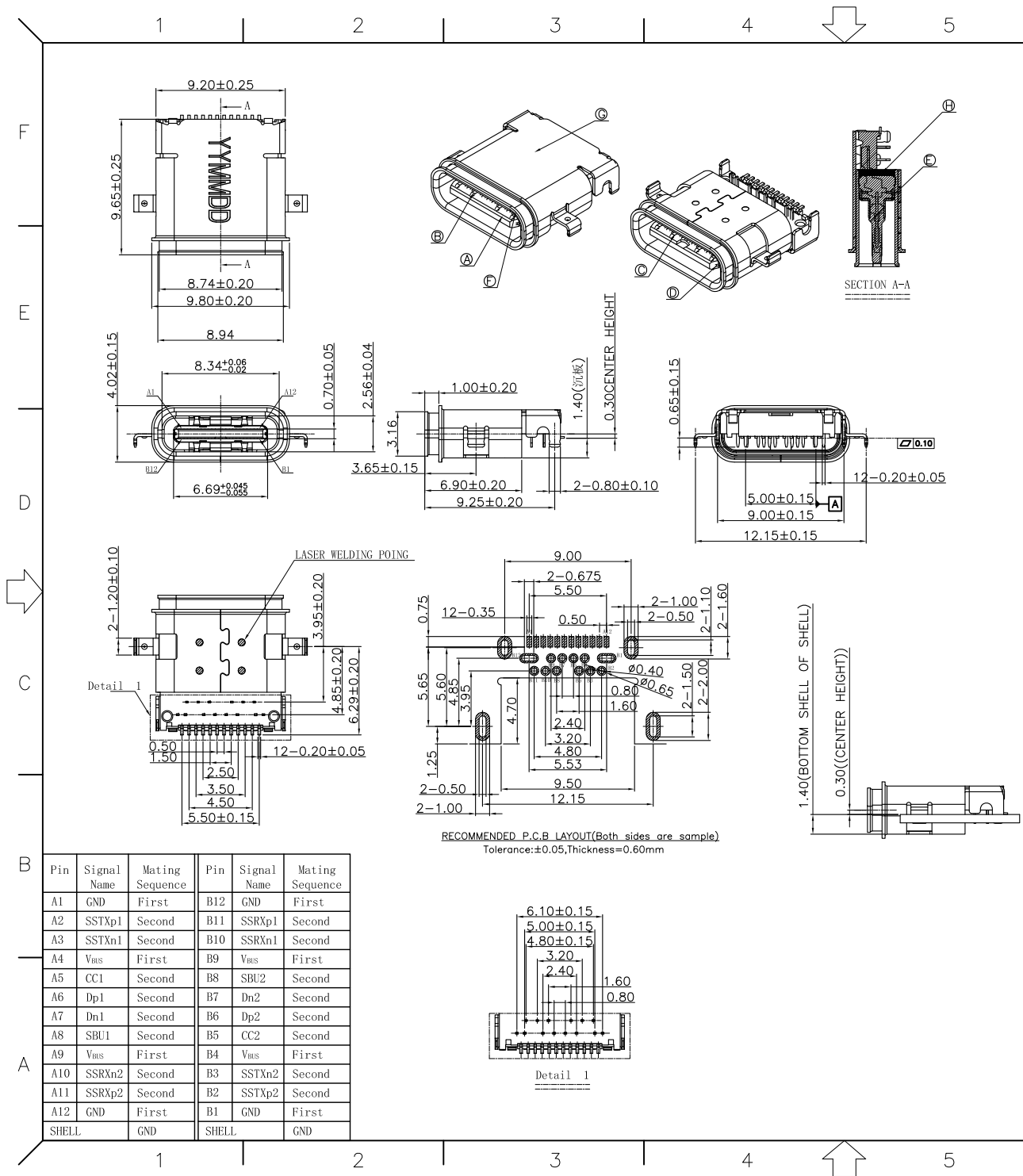

REV.	ECN NO OR DESCRIPTION	REVISED	DATE
A	PDR RELEASE	EVEN	2020.10.29
B	ECN NO.L202012-C07	EVEN	2021.03.03

The port of the Inner shell is rolled as 3.16*8.94 for seal purpose

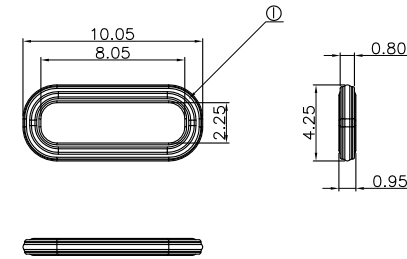
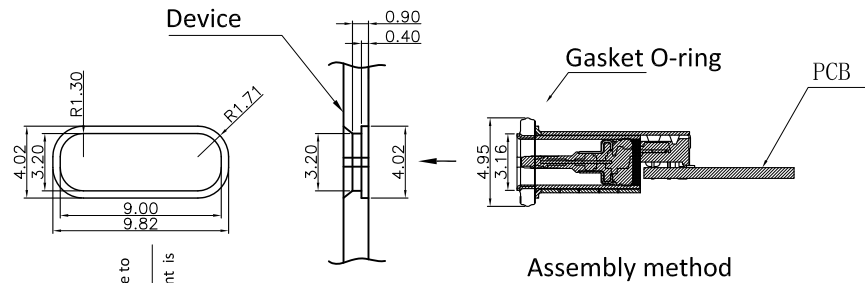

Specs of the O-ring we suggest is Silicon rubber
The O-ring dimension after compressed is 10.75*4.95

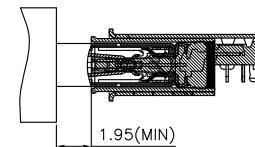
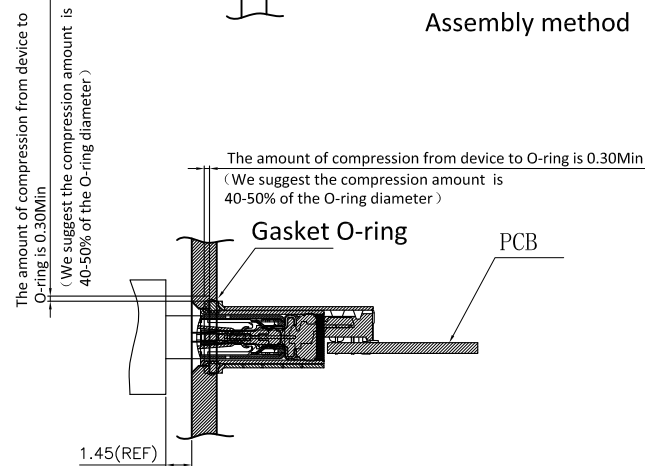

NO	DESCRIPTION	QTY	MATERIAL	PLATING & COLOR
UNLESS OTHERWISE SPECIFIED TOLERANCES		信音科技(香港)有限公司		
DECIMALS:	ANGLES:	TITLE	USB TYPE C ,DIP TYPE(WATERPROOF)	
X :±0.5	X :±2°	DWN	EVEN 2021.03.03	PART NO. 2UB1783-CW1111F
X.X :±0.3	X.X :±1°	CHKD	SCALE 1:1	UNIT: mm
X.XX :±0.2		APVD	ANGELA2021.03.03	SIZE: A3 SHEET:3 OF 3 REV: B
CUSTOMER COPY				

内壳翻边3.16*8.94密封方式

REV.	ECN NO OR DESCRIPTION	REVISED	DATE
A	PDR RELEASE	EVEN	2020.10.29
B	ECN NO.L202012-C07	EVEN	2021.03.03

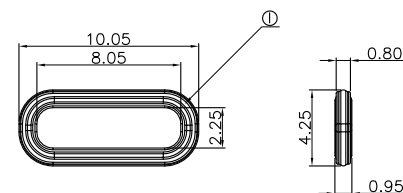
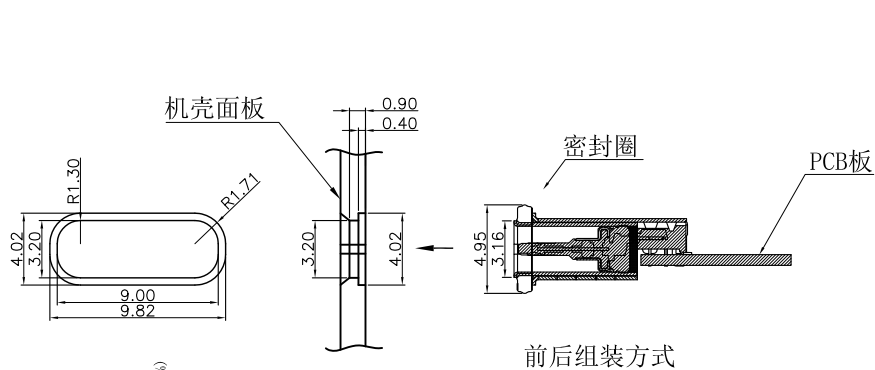

建议防水圈规格 (材质硅橡胶)
压缩后外形尺寸10.75*4.95

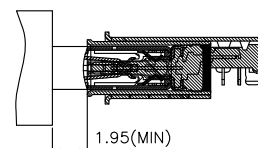
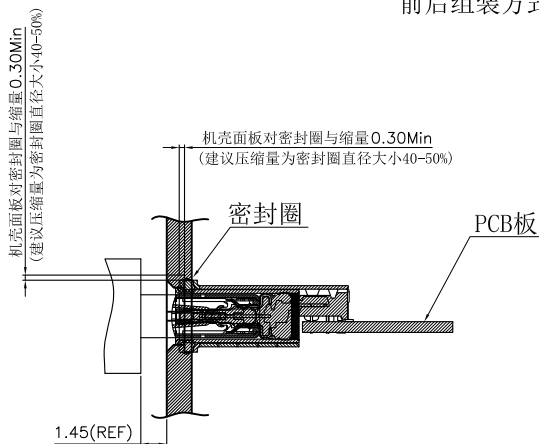

NO	DESCRIPTION	QTY	MATERIAL	PLATING & COLOR
UNLESS OTHERWISE SPECIFIED TOLERANCES		信音科技(香港)有限公司		
DECIMALS:	ANGLES:	TITLE	USB TYPE C ,DIP TYPE(WATERPROOF)	
X :±0.5	X :±2°	DWN	EVEN 2021.03.03	PART NO. 2UB1783-CW1111F
X.X :±0.3	X.X :±1°	CHKD	SCALE 1:1	UNIT: mm
X.XX :±0.2		APVD	ANGELA2021.03.03	SIZE: A3 SHEET:2 OF 3
CUSTOMER COPY				
REV: B				