

| REV. | ECN NO OR DESCRIPTION | REVISED | DATE |
|------|-----------------------|---------|------------|
| A | NEW RELEASE | ZW | 2012.11.22 |

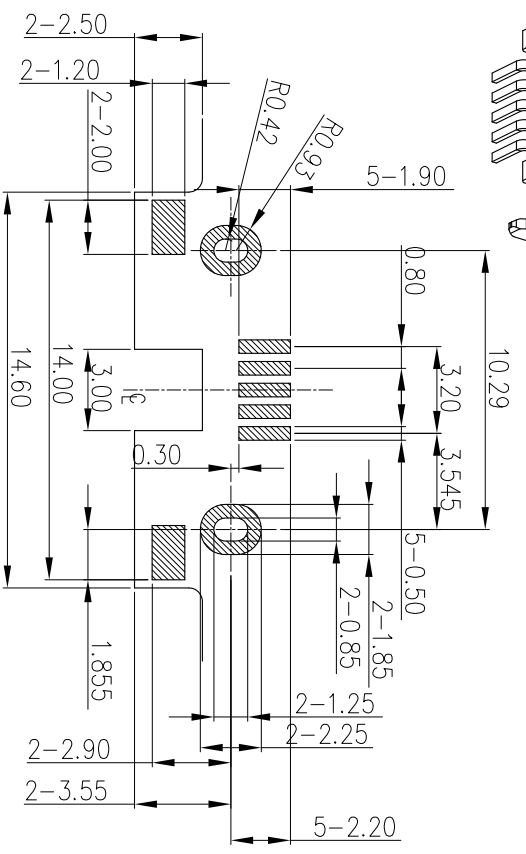

RECOMMENDED PCB LAYOUT(thickness 1.2mm)
 TOP VIEW(TOLERANCE ±0.05)

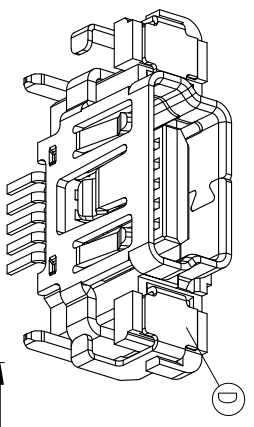
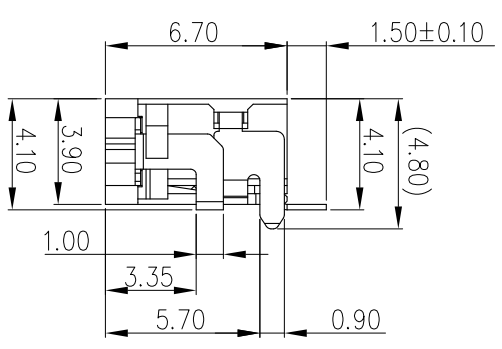
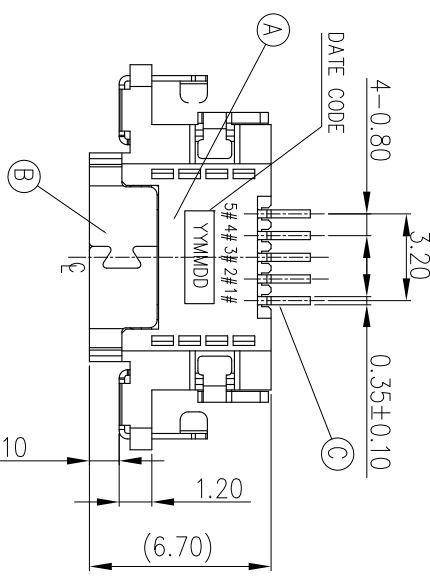
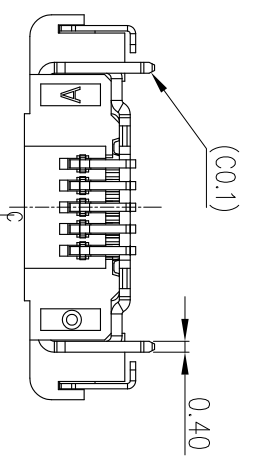
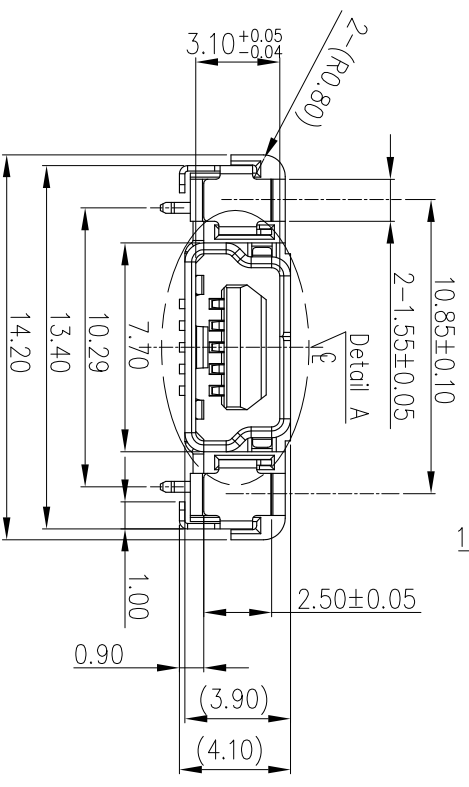

| UNLESS OTHERWISE SPECIFIED TOLERANCES | | SINGATRON ENTERPRISE CO., LTD. | |
|---------------------------------------|----------|--|--|
| DECIMALS: | ANGLES: | 信亨企業股份有限公司 | |
| X : ±0.5 | X : ±2° | MINI USB CONNECTOR PART NO. ZUB2025-000111F SCALEN/A UNIT: mm SHEET: 10F2 REV: A | |
| XX : ±0.3 | XX : ±1° | | |
| XXX : ±0.2 | | | |
| APVD SEAN | | CUSTOMER COPY | |

1 2 3 4 5 6 7 8

| REV. | ECN NO OR DESCRIPTION | REVISED | DATE |
|------|-----------------------|---------|------------|
| A | NEW RELEASE | ZW | 2012.11.22 |

NOTES:

- ELECTRICAL CHARACTERISTICS:
 - CURRENT RATING: 1.0A MAX
 - WORKING RATED VOLTAGE: 30V DC
 - CONTACT RESISTANCE: 50mΩ MAX
 - DIELECTRIC WITHSTANDING VOLTAGE: 100V AC FOR ONE MINUTE.
 - INSULATION RESISTANCE: 100MΩ MIN. MEASURED BY 100 VDC
- MECHANICAL CHARACTERISTICS:
 - INSERTION FORCE : 3.57 Kgf MAX
 - WITHDRAWAL FORCE : 0.7 Kgf MIN
 - AFTER LIFE TEST: 0.31 Kgf MIN
 - LIFE TEST: 5000 CYCLES MIN.
 - PACKING: TAPE&REEL
 - HALOGEN FREE PRODUCT IDENTIFICATION LABEL ON PACKAGING.
 - OTHER GENERAL SPEC. TO REFER "ZUB2025 SERIES SPEC".
 - PART NO. ZUB2025 - 0 0 0 1 1 1 F

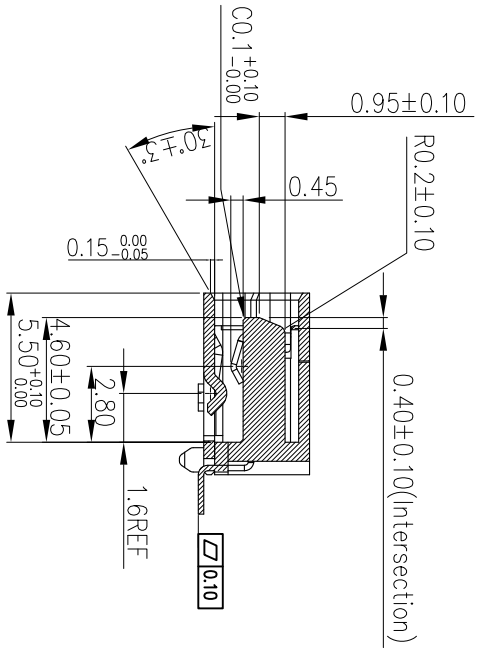
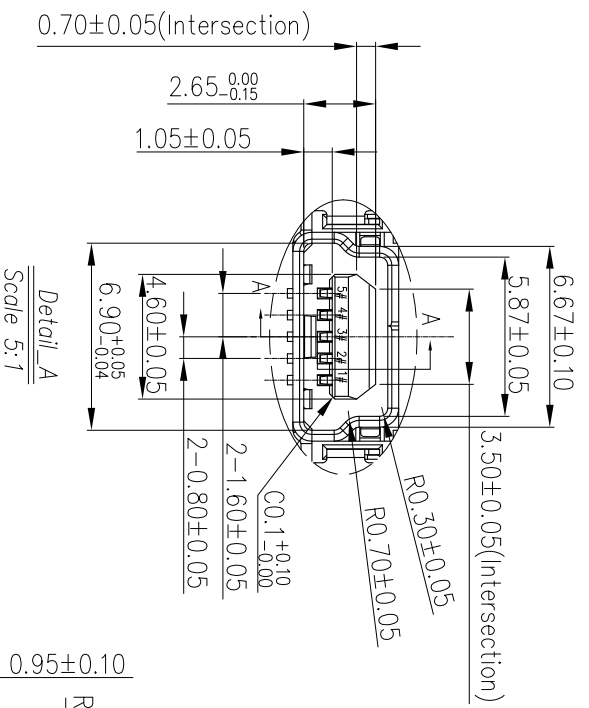
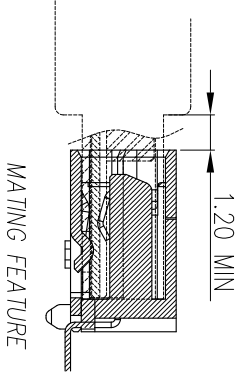

Section A-A
Scale 5:1

| | |
|---------|----------|
| 1 | VCC |
| 2 | -DATA |
| 3 | +DATA |
| 4 | ID |
| 5 | GROUND |
| PIN NO. | PIN NAME |

| | | | | |
|-----|-------------|-----|----------------------------|--|
| D | METAL EAR | 2 | COPPER ALLOY | GOLD FLASH OVER ALL |
| C | CONTACT | 5 | COPPER ALLOY | 50" MIN GOLD AND 250" MIN PGM PLATING ON CONTACT MATING AREA. GOLD FLASH PLATING ON SOLDER TAIL AND NICKEL UNDER PLATING |
| B | SHELL | 1 | COPPER ALLOY | NICKEL PLATING OVERALL |
| A | HOUSING | 1 | HIGH THERMOPLASTIC UL-94V0 | BLACK |
| NO. | DESCRIPTION | QTY | MATERIAL | PLATING & COLOR |

UNLESS OTHERWISE SPECIFIED TOLERANCES

DECIMALS: ANGLES:

X : ±0.5 X : ±2°
 XX : ±0.3 XX : ±1°
 XXX : ±0.2

Singatron Enterprise Co., Ltd.
 信亨企業股份有限公司

TITLE: MINI USB CONNECTOR

DWM ZW PART NO. ZUB2025-000111F
 CHKD KIM SCALE N/A UNIT: mm
 APVD SEAN SIZE: A3 SHEET: 20F2 REV: A

CUSTOMER COPY