

REV. ECN NO OR DESCRIPTION	REVISED	DATE
A PRODUCT RELEASE	Ares	2012.02.24

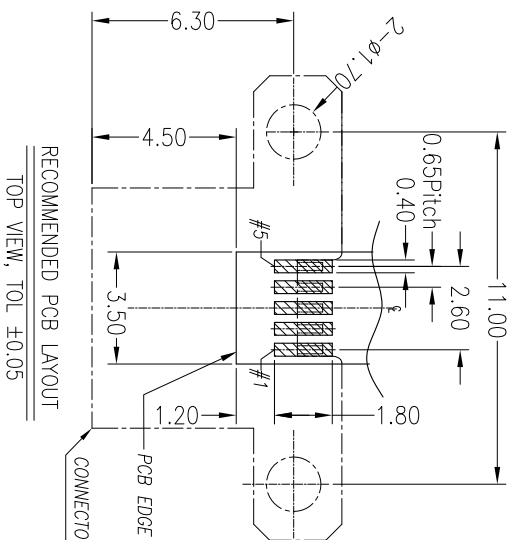

- SPECIFICATIONS:
- ELECTRICAL CHARACTERISTICS:
    - RATING: 2A (PIN1/5), 0.5A (PIN2/3/4)
    - CONTACT RESISTANCE: 30mΩ MAX (INITIAL) 40mΩ MAX (FINAL)
    - DIELECTRIC WITHSTANDING VOLTAGE: 500V AC FOR ONE MINUTE.
    - INSULATION RESISTANCE: 100M Ω·MIN. MEASURED BY 500 VDC
  - MECHANICAL CHARACTERISTICS:
    - INSERTION FORCE : 3.6 KGF (MAX)
    - WITHDRAWAL FORCE : 0.8 KGF (Reference)
    - LIFE TEST: 10,000 CYCLES.
    - AFTER DURABILITY, THE STRENGTH OF SHELL AND BODY ASSEMBLY SHALL LARGER THAN MAX INSERTION FORCE 3.6KGF.
    - TO CONFORM TO THE SINGATRON HSF SPEC.
    - HALOGEN FREE PRODUCT IDENTIFICATION MARK ON PRODUCT:
    - HALOGEN FREE PRODUCT IDENTIFICATION LABEL ON PACKAGING:
    - FOR REFLOW SOLDERING LEAD-FREE PROCESS.
    - PLUG INTERFACE DIMENSIONS CONFORM TO USB2.0 SPEC.
    - PACKAGING: TAPE & REEL.

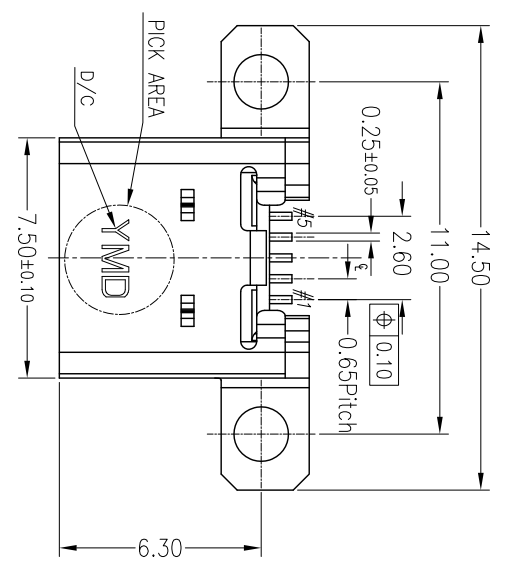
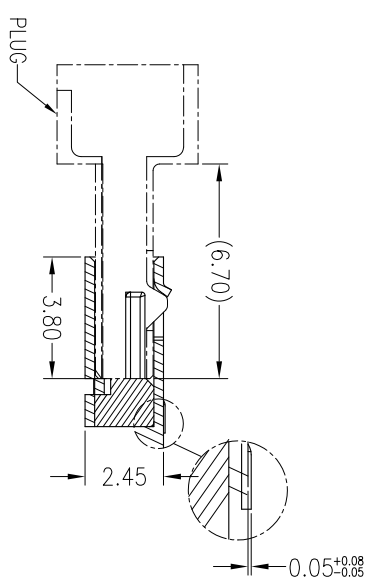
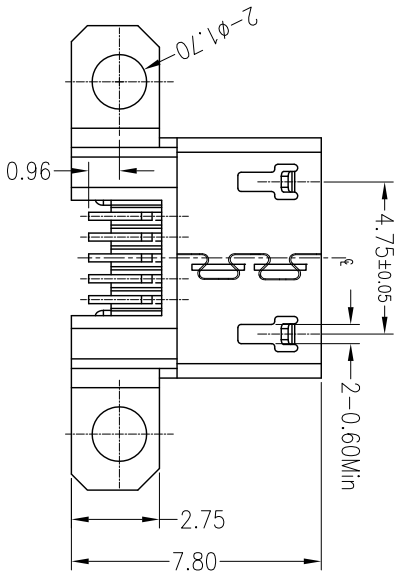
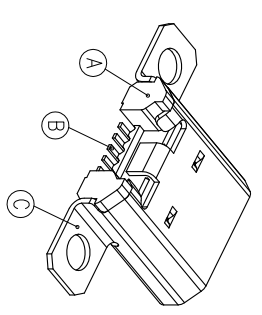
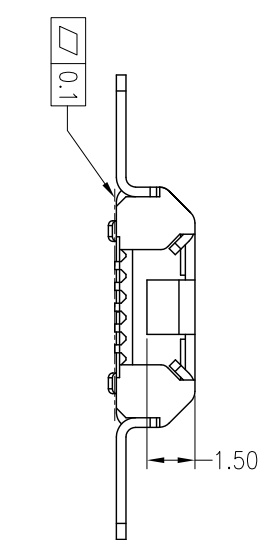
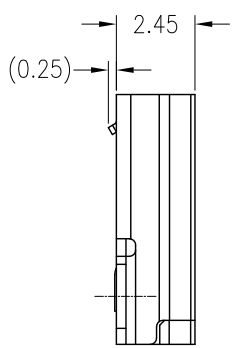
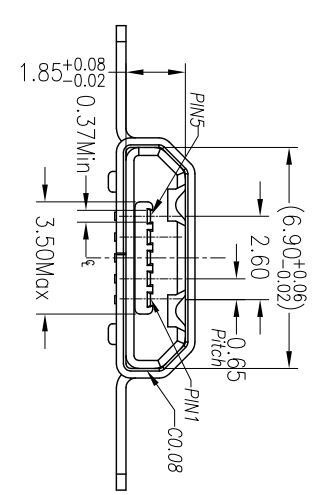

C	SHELL	1	STAINLESS STEEL 0.30T	Matt Tin
B	CONTACT	5	COPPER ALLOY	Au 30u" ON CONTACT AREA GOLD FLASH ON SOLDER AREA
A	BODY	1	HI-TEMP. THERMO-PLASTIC UL94V-0	BLACK
NO	DESCRIPTION	QTY	MATERIAL	PLATING & COLOR

UNLESS OTHERWISE SPECIFIED TOLERANCES

Singatron Enterprise Co., Ltd.  
信晉企業股份有限公司

DECIMALS:	ANGLES:	TITLE	MICRO USB B TYPE REVERSE RECEPTACLE
X : ±0.50	X : ±2°	DWN	Ares 2012/02/24
X.X : ±0.30	X.X : ±1°	CHKD	Wahon 2012/02/24
X.XX : ±0.20		APVD	Liao 2012/02/24

PART NO. 2UB2105-000111F  
SCALE 5:1 UNIT: mm  
SIZE: A3 SHEET: 1 OF 1 REV: A  
CUSTOMER COPY