

(CH=1.225REF)

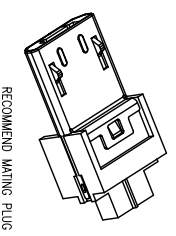
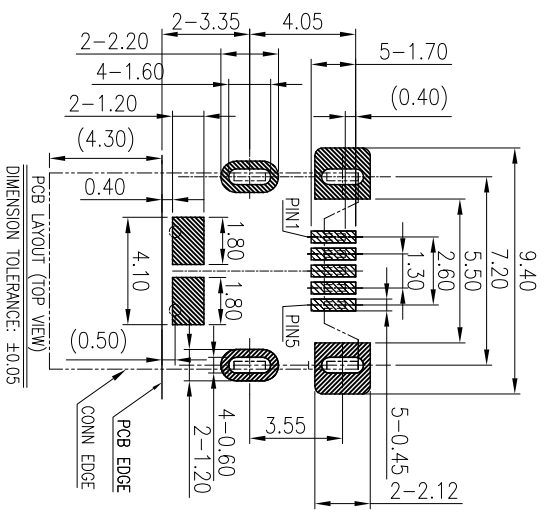
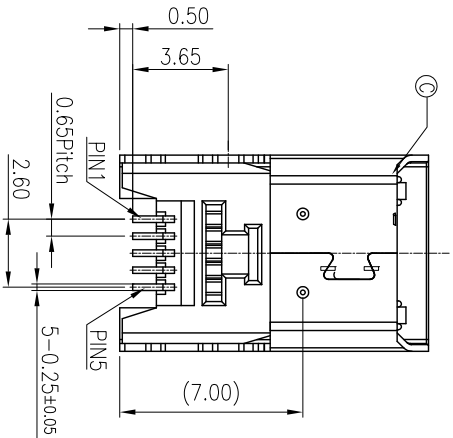
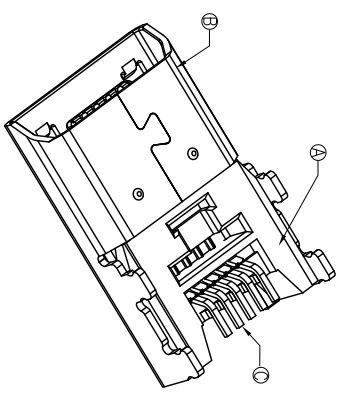
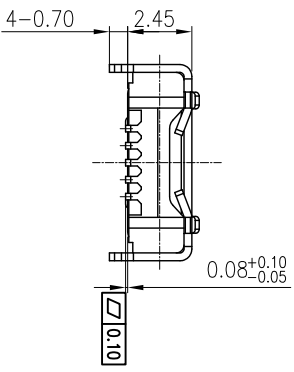
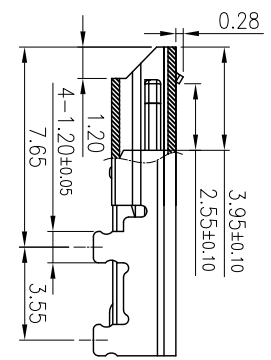

RECOMMEND MATING PLUG

- SPECIFICATIONS:
- ELECTRICAL CHARACTERISTICS:
 - RATING: 1.8A (PIN1/5), 0.5A (PIN2/3/4)
 - CONTACT RESISTANCE: 30mΩ MAX.(INITIAL) 40mΩ MAX.(FINAL)
 - DIELECTRIC WITHSTANDING VOLTAGE: 100V AC FOR ONE MINUTE.
 - INSULATION RESISTANCE: 100MΩ MIN.
 - MECHANICAL CHARACTERISTICS:
 - INSERTION FORCE: 3.6 KGF (MAX.)
 - WITHDRAWAL FORCE: 0.8 KGF(Reference)
 - LIFE TEST: 10,000 CYCLES.
 - TO CONFORM TO THE SINGATRON HSF SPEC.
 - HALOGEN FREE PRODUCT IDENTIFICATION MARK ON PRODUCT.
 - HALOGEN FREE PRODUCT IDENTIFICATION LABEL ON PACKAGING.
 - FOR REFLOW SOLDERING: LEAD-FREE PROCESS.
 - SOLDER HEAT RESISTANCE REFLOW SOLDERING: 260°C, 10SECS.
 - PLUG INTERFACE DIMENSIONS CONFORM TO USB2.0 SPEC.
 - PACKAGING: TAPE & REEL.

Micro Usb Pin Assignments:

Contact Number	Signal Name
1	VBUS
2	D-
3	D+
4	ID
5	GND
	Shield

NO	DESCRIPTION	QTY	MATERIAL	PLATING & COLOR
C	SHELL	1	STAINLESS STEEL,0.30T	NICKEL PLATED
B	CONTACT	5	COPPER ALLOY,0.20T	30u" Au ON CONTACT AREA AND GOLD FLASH ON SOLDER AREA ALL OVER NICKEL PLATED
A	BODY	1	HIGH TEMP. THERMOPLASTIC UL 94V-0	BLACK

UNLESS OTHERWISE SPECIFIED TOLERANCES

DECIMALS:	ANGLES:
X : ±0.5	X : ±2°
X.X : ±0.3	X.X : ±1'
X.XX : ±0.2	

Singatron Enterprise Co., Ltd.
 信音企業股份有限公司
MICRO-USB B TYPE RECEPTACLE
 PART NO. 2UB2124-020111F
 DWN REX 15/06/05 SCALE 5:1 UNIT: mm
 CHKD WZJ 15/06/05 SIZE: A3 SHEET: 1 OF 1 REV: A
 APVD ZLZ 15/06/05
CUSTOMER COPY

REV./ECN	NO OR DESCRIPTION	REVISED	DATE
A	PRODUCT RELEASE	REX	2015.06.02