

REV	ECN NO OR DESCRIPTION	REVISED	DATE
A	PRODUCT RELEASE	REX	2014.06.26

- SPECIFICATIONS:**
- ELECTRICAL CHARACTERISTICS:**
 - 1-1. RATING: 1.8A (PIN1/5), 0.5A (PIN2/3/4)
 - 1-2. CONTACT RESISTANCE: 30mΩ MAX.(INITIAL) 40mΩ MAX.(FINAL)
 - 1-3. DIELECTRIC WITHSTANDING VOLTAGE: 100V AC FOR ONE MINUTE.
 - 1-4. INSULATION RESISTANCE: 100M ΩMIN. MEASURED BY 500 VDC
 - MECHANICAL CHARACTERISTICS:**
 - 2-1. INSERTION FORCE: 3.6 KGf (MAX)
 - 2-2. WITHDRAWAL FORCE: 0.8 KGf(Reference)
 - LIFE TEST: 10,000 CYCLES.
 - TO CONFORM TO THE SINGATRON HSF SPEC.
 - HALOGEN FREE PRODUCT IDENTIFICATION MARK ON PRODUCT:
 - HALOGEN FREE PRODUCT IDENTIFICATION LABEL ON PACKAGING:
 - FOR REFLOW SOLDERING LEAD-FREE PROCESS.
 - SOLDER HEAT RESISTANCE REFLOW SOLDERING 260°C. 10SECS.
 - PLUG INTERFACE DIMENSIONS CONFORM TO USB2.0 SPEC.
 - PACKAGING: TAPE & REEL.

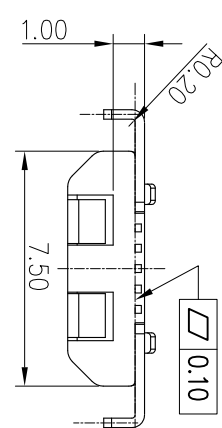
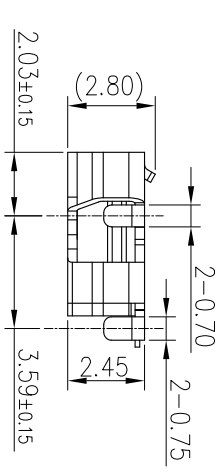
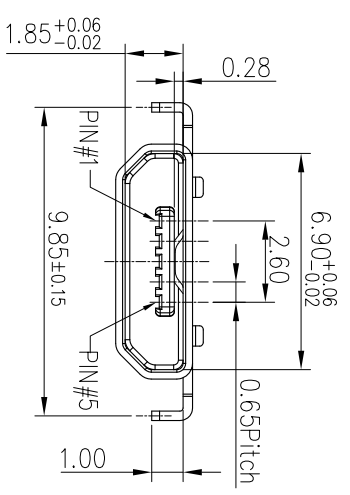
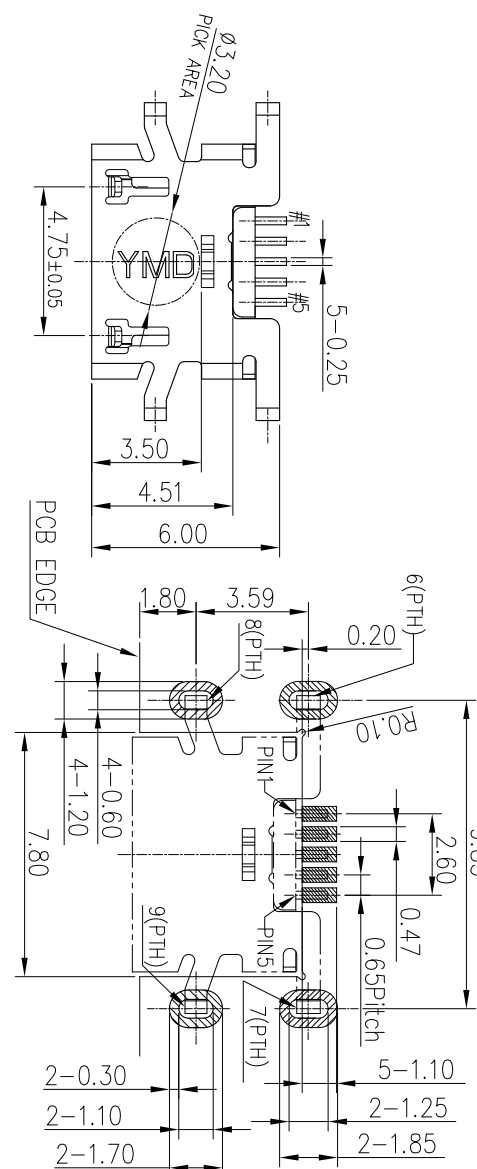

Micro Usb Pin Assignments:

Contact Number	Signal Name
1	VBUS
2	D-
3	D+
4	ID
5	GND
	Shield

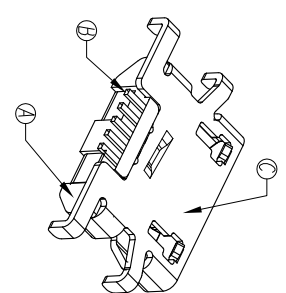
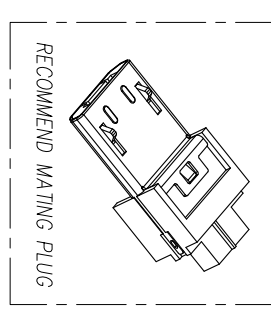
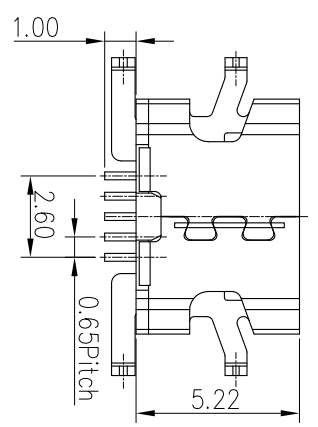

C	SHELL	1	STAINLESS STEEL 0.30T	NI PLATED
B	CONTACT	5	COPPER ALLOY 0.20T	30μ Au ON CONTACT AREA GOLD FLASH ON SOLDER AREA All Over Nickel Plated
A	HOUSING	1	HI-TEMP. THERMO-PLASTIC UL94V-0	BLACK
NO	DESCRIPTION	QTY	MATERIAL	PLATING & COLOR
UNLESS OTHERWISE SPECIFIED TOLERANCES				
Singaton Enterprise Co., Ltd. 信音企業股份有限公司				
DECIMALS: ANGLES:				
X	:±0.5	X	:±2°	
X.X	:±0.3	X.X	:±1°	
X.XX	:±0.2			
TITLE MICRO USB B TYPE RECEPTACLE				
DWN	REV 2014.06.27	PART NO.	2UB2133-000112F	
CHKD	WZJ 2014.06.27	SCALE	5:1	UNIT: mm
APVD	Luo 2014.06.27	SIZE:	A3	SHEET: 1 OF 1
REV: A				
CUSTOMER COPY				