

REV.	ECN NO OR DESCRIPTION	REVISED	DATE
A	PRODUCT RELEASE	Junkang	2015.06.08

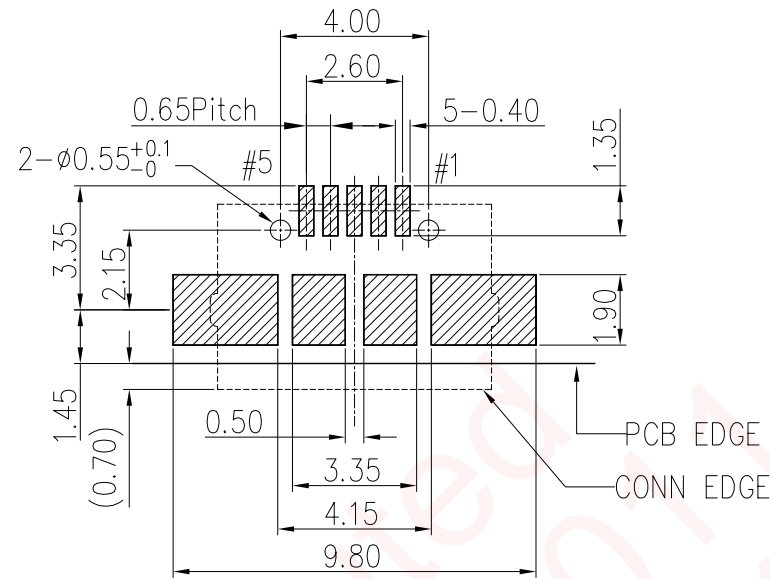

RECOMMEND PCB LAYOUT 0.80T
TOP VIEW (TOL.±0.05mm)

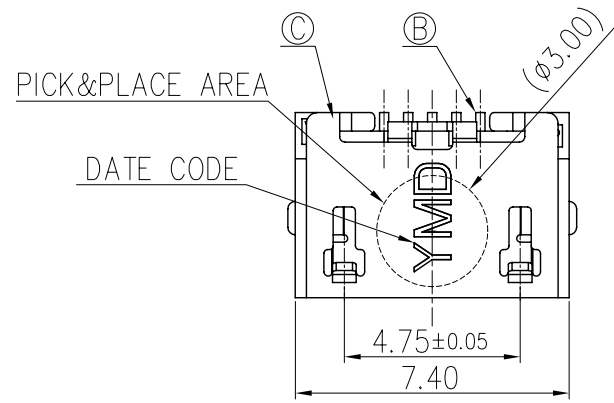
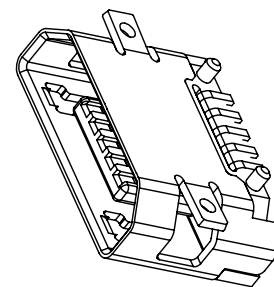
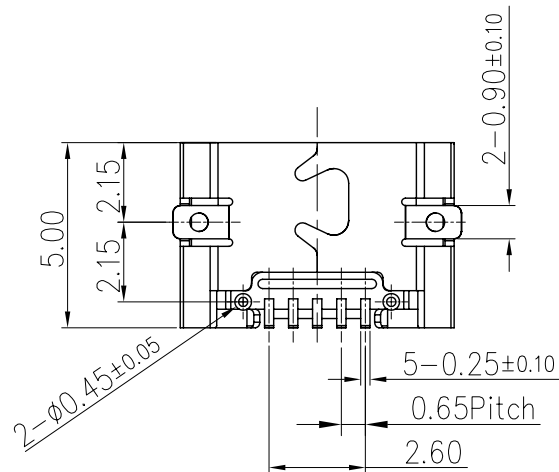
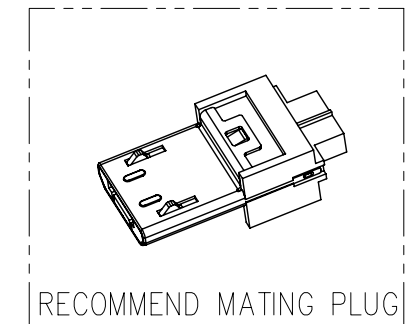
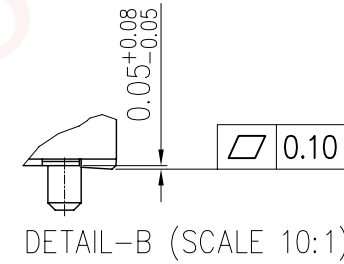
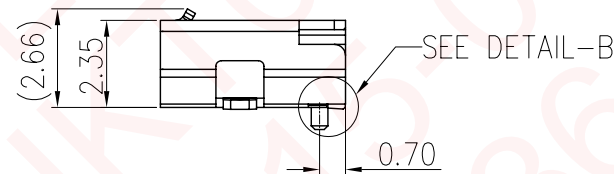
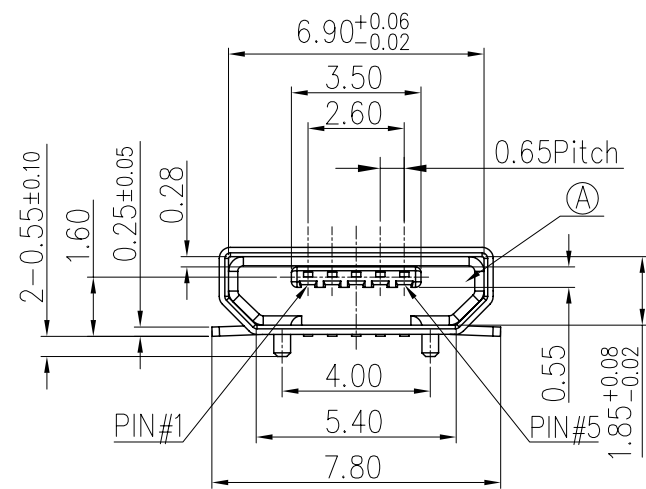

Micro Usb Pin Assignments:

Contact Number	Signal Name
1	VBUS
2	D-
3	D+
4	ID
5	GND
SHELL	Shield

SPECIFICATIONS:

- ELECTRICAL CHARACTERISTICS:
 - RATING: 1.8A (PIN1/5), 0.5A (PIN2/3/4)
 - CONTACT RESISTANCE: 30mΩ MAX.(INITIAL)40mΩ MAX.(FINAL)
 - DIELECTRIC WITHSTANDING VOLTAGE: 100V AC FOR ONE MINUTE.
 - INSULATION RESISTANCE: 100MΩ MIN.
- MECHANICAL CHARACTERISTICS:
 - INSERTION FORCE: 3.6 KGF (MAX.)
 - WITHDRAWAL FORCE: 0.8 KGF(Reference)
- LIFE TEST: 10,000 CYCLES.
- TO CONFORM TO THE SINGATRON HSF SPEC.
- HALOGEN FREE PRODUCT IDENTIFICATION MARK ON PRODUCT:
- HALOGEN FREE PRODUCT IDENTIFICATION LABEL ON PACKAGING:
- FOR REFLOW SOLDERING LEAD-FREE PROCESS.
- SOLDER HEAT RESISTANCE REFLOW SOLDERING 260°C 10SECS.
- PLUG INTERFACE DIMENSIONS COMFORM TO USB2.0 SPEC.
- PACKAGING: TAPE & REEL.

C	SHELL	1	SUS 301 0.25T	Ni60u"Min
B	CONTACT	5	C2680-H 0.15T	Gold Flash ON CONTACT AREA And Solder AREA, All Over Nickel Plated
A	HOUSING	1	LCP+30%GF UL94V-0	BLACK
NO	DESCRIPTION	QTY	MATERIAL	PLATING & COLOR

UNLESS OTHERWISE SPECIFIED TOLERANCES		Singatron Enterprise Co., Ltd. 信音企業股份有限公司		
TITLE	MICRO USB B TYPE RECEPTACLE			
DWN	Nanlin-Chen 15/6/18	PART NO.	2UB2141-000131F	
CHKD	Qicai-Hu 15/6/18	SCALE 5:1	UNIT: mm	
APVD	Zij-Zhou 15/6/18	SIZE: A3	SHEET: 10F1	REV: A
CUSTOMER COPY				