

TOP VIEW, TOL ±0.05  
RECOMMENDED PCB LAYOUT T=1.20mm

- SPECIFICATIONS:
- ELECTRICAL CHARACTERISTICS:
    - RATING: 3A (PIN1/5), 1A (PIN2/3/4)
    - CONTACT RESISTANCE: 30mΩ MAX.(INITIAL) 50mΩ MAX.(FINAL)
    - DIELECTRIC WITHSTANDING VOLTAGE: 100V AC FOR ONE MINUTE.
    - INSULATION RESISTANCE:100MΩ/MIN.MEASURED BY 500VDC FOR FINISH.
  - MECHANICAL CHARACTERISTICS:
    - INSERTION FORCE : 3.6 KGF (MAX)
    - WITHDRAWAL FORCE : 0.8 KGf(Reference)
    - LIFE TEST: 10,000 CYCLES .
    - OTHER GENERAL SPEC TO REFER "2UB2141-002111F SPEC".
    - HALOGEN FREE PRODUCT IDENTIFICATION MARK ON PRODUCT:
    - HALOGEN FREE PRODUCT IDENTIFICATION LABEL ON PACKAGING:
    - FOR REFLOW SOLDERING LEAD-FREE PROCESS.
    - PLUG INTERFACE DIMENSIONS CONFORM TO USB2.0 SPEC.
    - PACKAGING: TAPE & REEL.

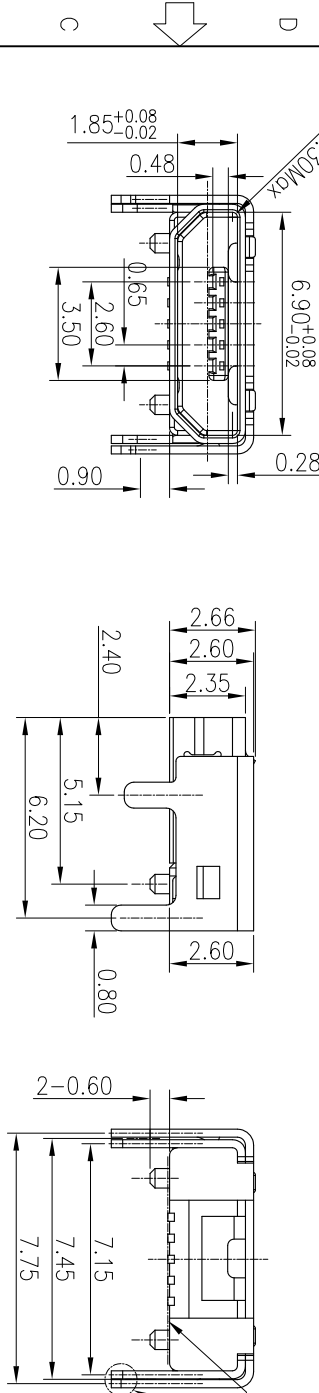

DETAIL A  
SCALE 8:1

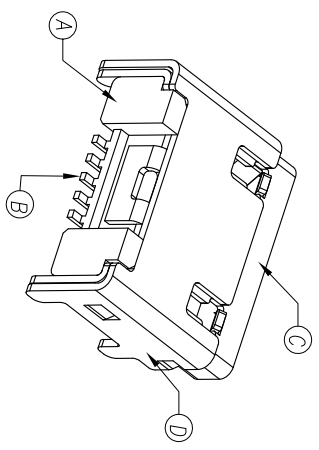
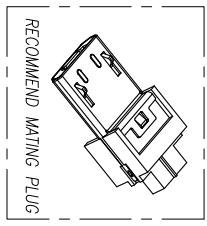
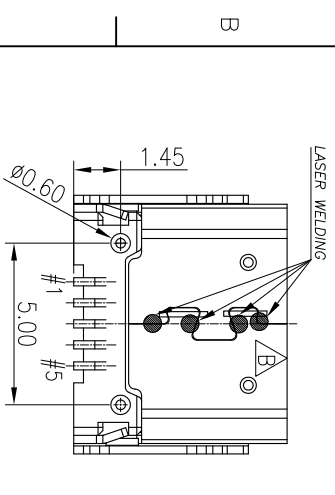
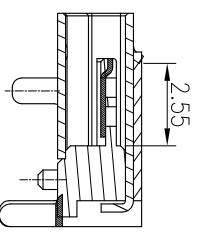

NO	DESCRIPTION	QTY	MATERIAL	PLATING & COLOR
D	COVER	1	STAINLESS STEEL 0.25T	GOLD FLASH ON SOLDER AREA ALL OVER 60μm NICKEL PLATED
C	SHELL	1	STAINLESS STEEL 0.25T	GOLD FLASH ON SOLDER AREA ALL OVER 60μm NICKEL PLATED
B	CONTACT	5	COPPER ALLOY 0.20T	30μm ON CONTACT AREA GOLD FLASH ON SOLDER AREA ALL OVER NICKEL PLATED
A	HOUSING	1	LCP E130I 30%GF UL94V-0	BLACK

UNLESS OTHERWISE SPECIFIED TOLERANCES

DECIMALS: ANGLES: X : ±2°  
X.X : ±0.3 X.X : ±1°  
X.XX : ±0.2

TITLE: MICRO USB B TYPE RECEPTACLE  
PART NO. 2UB2141-002111F

Singatron Enterprise Co., Ltd.  
信晉企業股份有限公司

APVD LMO 14/8/25 SIZE: A3 SHEET: 1 OF 1 REV: B

CUSTOMER COPY