

REV.	ECN NO OR DESCRIPTION	REVISED	DATE
A	PRODUCTED RELEASED	Junkang	2014.09.01
B	ECN NO.:C190203 UPDATE PCB LAYOUT DIMENSION	Cheney	2019.02.26

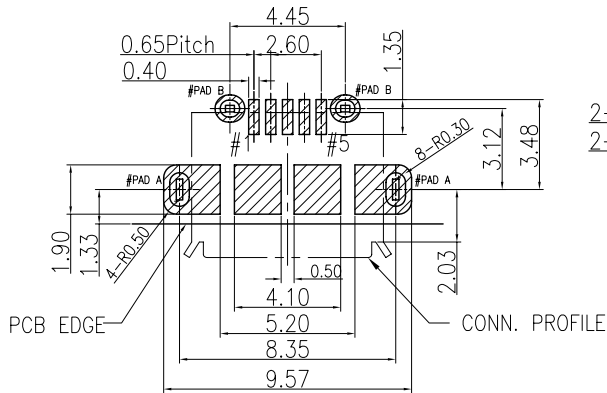

RECOMMENDED PCB LAYOUT T=1.20mm
TOP VIEW, TOL ±0.05

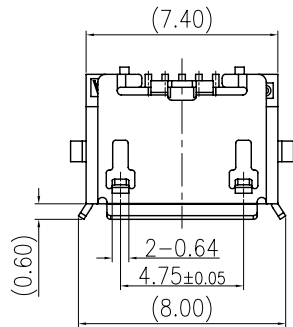
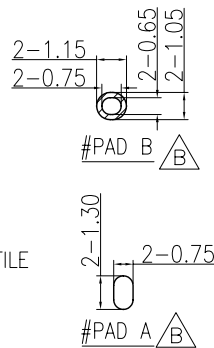

SPECIFICATIONS:

- ELECTRICAL CHARACTERISTICS:
 - RATING: 1.8A (PIN1/5), 1.0A (PIN2/3/4)
 - CONTACT RESISTANCE: 30mΩMAX.(INITIAL),40mΩMAX.(FINAL)
 - DIELECTRIC WITHSTANDING VOLTAGE: 100VAC FOR ONE MINUTE.
 - INSULATION RESISTANCE: 100MΩ MIN.(Finish). MEASURED BY 500VDC.
- MECHANICAL CHARACTERISTICS:
 - INSERTION FORCE : 3.6 KGF (MAX.)
 - WITHDRAWAL FORCE : 0.8 KGF(Reference)
- LIFE TEST: 10,000 CYCLES.
- TO CONFORM TO THE SINGATRON HSF SPEC.
- OTHER GENERAL SPEC TO REFER "2UB2162-003111F SPEC".
- HALOGEN FREE PRODUCT IDENTIFICATION MARK ON PRODUCT:
- HALOGEN FREE PRODUCT IDENTIFICATION LABEL ON PACKAGING:
- FOR REFLOW SOLDERING LEAD-FREE PROCESS.
- PLUG INTERFACE DIMENSIONS COMFORM TO USB2.0 SPEC.
- PACKAGING: TAPE & REEL.

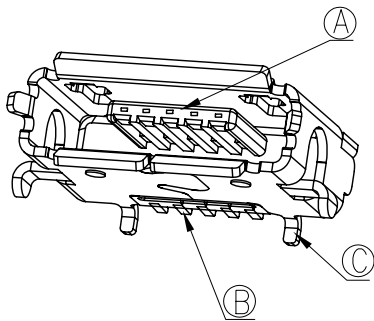
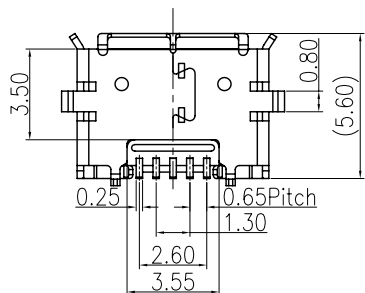
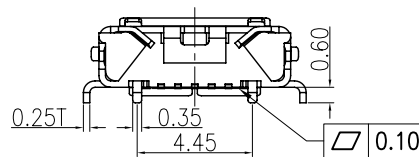
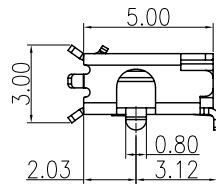
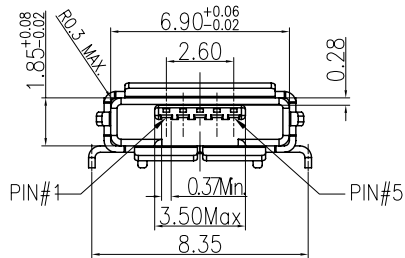

C	SHELL	1	STAINLESS 0.25T	TIN
B	CONTACT	5	COPPER ALLOY 0.15T	Au30u"Min on Contact Area and Au 1u" Min on Solder Area,Ni 50u" Min under plated
A	HOUSING	1	LCP+30%GF E130i UL94V-0	BLACK
NO	DESCRIPTION	QTY	MATERIAL	PLATING & COLOR
UNLESS OTHERWISE SPECIFIED TOLERANCES		Singatron Enterprise Co., Ltd. 信音企業股份有限公司		
DECIMALS: ANGLES:		TITLE: MICRO USB AB TYPE RECEPTACLE		
X	:±0.50	X	:±2°	DWN <small>Nanlin-Chen 19/03/07</small> PART NO. 2UB2162-003111F
X.X	:±0.30	X.X	:±1°	CHKD <small>Qicai-Hu 19/03/07</small> SCALE 5:1 UNIT: mm
X.XX	:±0.20	APVD <small>clint-lin 19/03/07</small>	SIZE: A3	SHEET:1 OF 1 REV: B
CUSTOMER COPY				