





REV.	ECN NO OR DESCRIPTION	REVISED	DATE
A	PDR NO: S230306-1A	Zwei Wu	2023.05.16

- SPECIFICATIONS:
- ELECTRICAL CHARACTERISTICS:
 - RATING: 1.8A (PIN1/5), 1.0A (PIN2/3/4)
 - CONTACT RESISTANCE: 30mΩMAX.(INITIAL), 40mΩMAX.(FINAL)
 - DILECTRIC WITHSTANDING VOLTAGE: 100VAC FOR ONE MINUTE.
 - INSULATION RESISTANCE: 100MΩ MIN.(Finish). MEASURED BY 500VDC.
 - MECHANICAL CHARACTERISTICS:
 - INSERTION FORCE : 3.6 KGf (MAX)
 - WITHDRAWAL FORCE : 0.8 KGf(Reference)
 - LIFE TEST: 10,000 CYCLES.
 - TO CONFORM TO THE SINGATRON HSF SPEC.
 - OTHER GENERAL SPEC TO REFER "2UB2162-003111F SPEC".
 - HALOGEN FREE PRODUCT IDENTIFICATION MARK ON PRODUCT: 
 - HALOGEN FREE PRODUCT IDENTIFICATION LABEL ON PACKAGING: 
 - FOR REFLOW SOLDERING LEAD-FREE PROCESS.
 - PLUG INTERFACE DIMENSIONS CONFORM TO USB2.0 SPEC.
 - PACKAGING: TAPE & REEL.

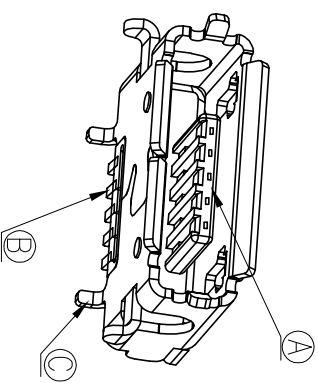
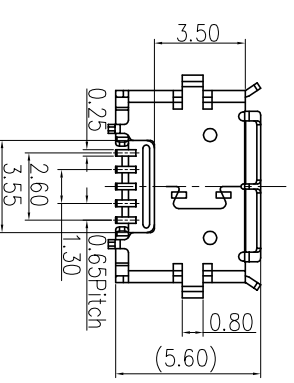
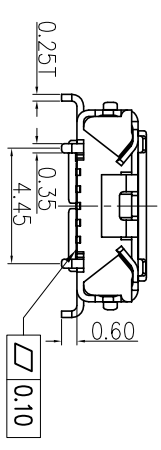
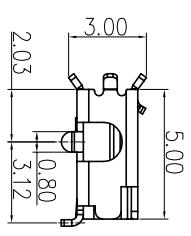
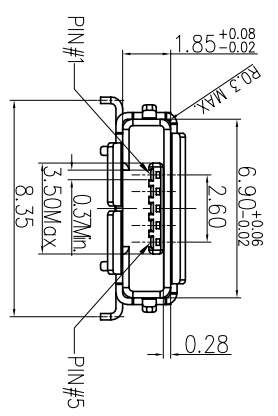
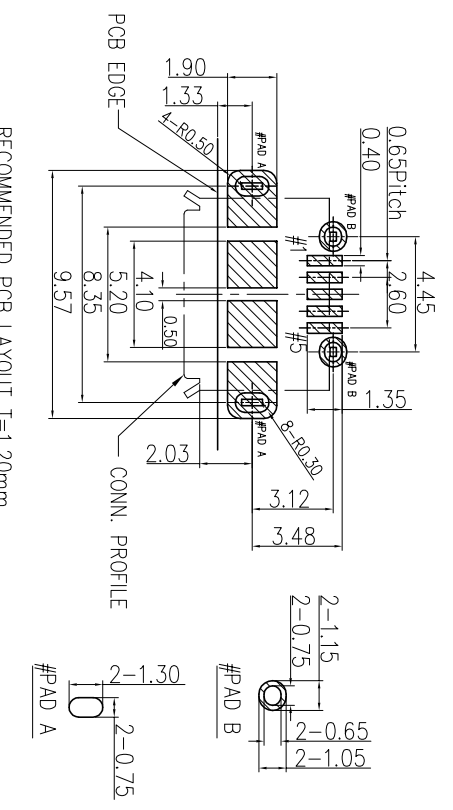

C	SHELL	1	STAINLESS 0.25T	TIN
B	CONTACT	5	COPPER ALLOY 0.15T	Au30u"Min on Contact Area and Au 1u" Min on Solder Area, Ni 50u" Min under plated
A	HOUSING	1	LCP+30%GF E130I UL94V-0	BLACK
UNLESS OTHERWISE SPECIFIED TOLERANCES				
 Singatron Enterprise Co., Ltd. 信音企業股份有限公司				
TITLE MICRO USB AB TYPE RECEPTACLE				
DWG Zwei Wu PART NO. 2UB2162-013111F				
CHKD Qicai Hu SCALE 5:1 UNIT: mm				
APVD Jim Deng SIZE: A3 SHEET: 1 OF 1 REV: A				
CUSTOMER COPY				

DECIMALS:	ANGLES:
X : ±0.50 X : ±2	
XX : ±0.30 X.X : ±1	
XXX : ±0.20	