

REV.	ECN NO OR DESCRIPTION	REVISED	DATE
A	PDR NO.:T211015-3A	XIAO	2022.03.17

SPECIFICATIONS:

1. ELECTRICAL CHARACTERISTICS:

- 1-1. CURRENT RATING: 1.8A (PIN1,4) ; OTHER CONTACTS 0.25A
- 1-2. CONTACT RESISTANCE: 30mΩ MAX.
- 1-3. DIELECTRIC WITHSTANDING VOLTAGE: 100V AC FOR 1 MINUTE
- 1-4. INSULATION RESISTANCE: 100MΩ MIN

2. MECHANICAL CHARACTERISTICS:

- 2-1. INSERTION FORCE : 35N MAX. INITIAL.
- 2-2. WITHDRAWAL FORCE : 10N MIN. INITIAL, 8N MIN. FOR AFTER TEST.

3. DURABILITY: 5,000 CYCLES,

4. OTHER SPEC TO REFER USB 3.0 SPEC.

5. TO CONFORM TO SINGATRON HAZARDOUS SUBSTANCE FREE SPEC.

6. HALOGEN FREE PRODUCT IDENTIFICATION MARK : Ⓞ

7. HALOGEN FREE PRODUCT IDENTIFICATION LABEL ON PACKAGING: 

8. FOR REFLOW SOLDERING LEAD-FREE PROCESS.

9. PACKAGING : TAPE & REEL.

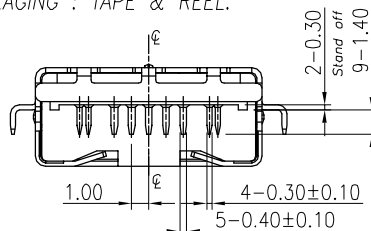
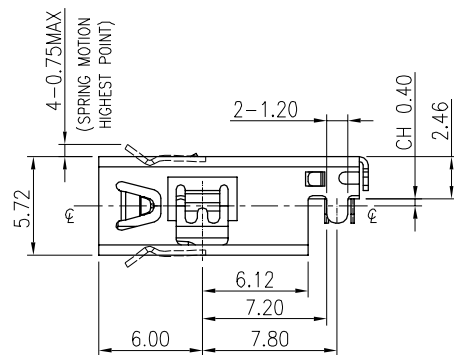
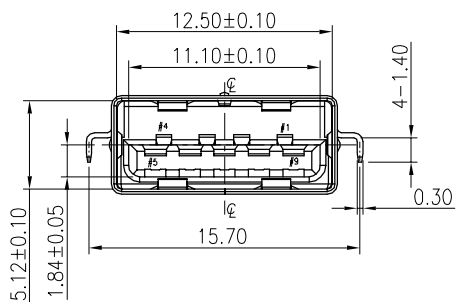
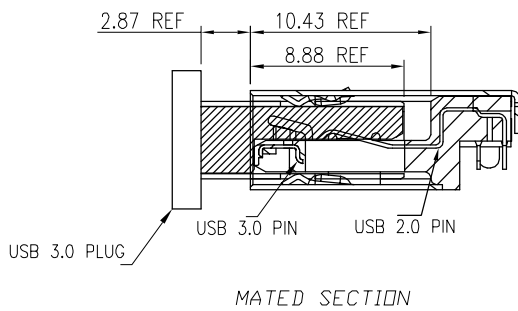
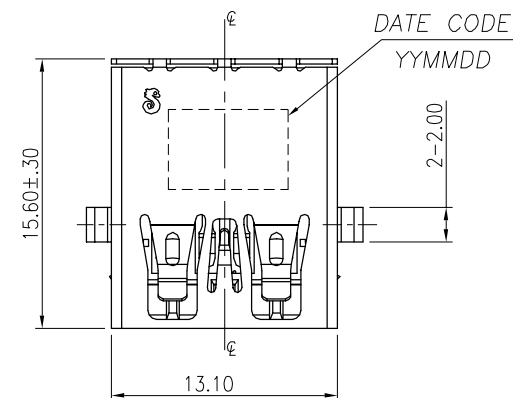

Pin NO.	Signal Assignment
# 1	VBUS
# 2	D-
# 3	D+
# 4	PGND
# 5	SSRX-
# 6	SSRX+
# 7	GND
# 8	SSTX-
# 9	SSTX+

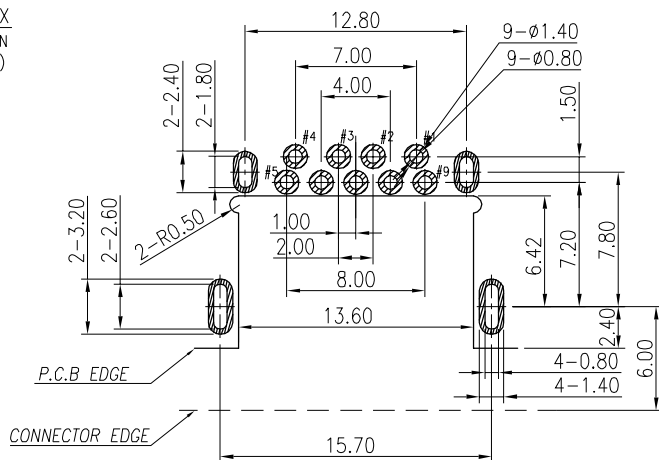
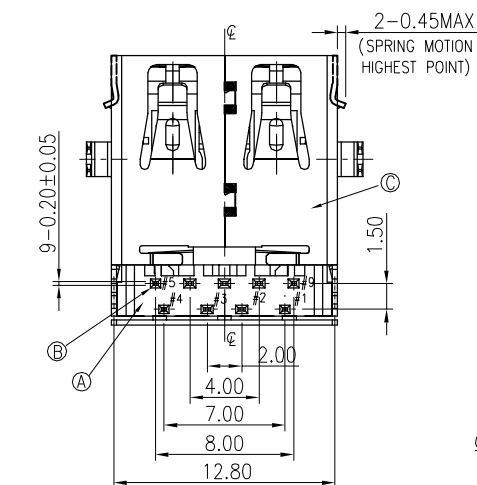

Gen 2 10G

C	SHELL	1	STEEL 0.3T	60µin Min. Solderable Nickel plating.
B	TERMINAL	9	COPPER ALLOY 0.2T	10µin Min. Gold plating on contact area, 40-80µin Min. Matte tin plating on solder tail area, 60µin Min. Nickel under plating.
A	HOUSING	1	HIGH TEMPERATURE THERMOPLASTIC UL94V-0	BLACK

NO	DESCRIPTION	QTY	MATERIAL	PLATING & COLOR
UNLESS OTHERWISE SPECIFIED TOLERANCES				
			Singatron Enterprise Co., Ltd. 信音企業股份有限公司	
DECIMALS:		ANGLES:		
TITLE		USB3.0 CONNECTOR		
DWN	xiao	PART NO. 2UB2308-000431F		
CHKD	allen	SCALE 1:1	UNIT: mm	Ⓞ
APVD	boye	SIZE: A3	SHEET: 10F1	REV: A
CUSTOMER COPY				