

- SPECIFICATIONS:
1. ELECTRICAL CHARACTERISTICS:
- 1-1. CURRENT RATING: 1.8A (PIN1-4) ; OTHER CONTACTS 0.25A
 - 1-2. CONTACT RESISTANCE: 30mΩ MAX.
 - 1-3. DIELECTRIC WITHSTANDING VOLTAGE: 100V AC FOR 1 MINUTE
 - 1-4. INSULATION RESISTANCE: 100MΩ MIN
2. MECHANICAL CHARACTERISTICS:
- 2-1. INSERTION FORCE : 3.5 kgf MAX
 - 2-2. WITHDRAWAL FORCE : 1.0 kgf MIN
- 3. DURABILITY: 5,000 CYCLES.
 - 4. OTHER SPEC TO REFER USB 3.0 SPEC.
 - 5. TO CONFORM TO SINGATRON HAZARDOUS SUBSTANCE FREE SPEC.
 - 6. HALOGEN FREE PRODUCT IDENTIFICATION MARK : ☉
 - 7. HALOGEN FREE PRODUCT IDENTIFICATION LABEL ON PACKAGING:
 - 8. FOR REFLOW SOLDERING LEAD-FREE PROCESS.
 - 9. PACKAGING : TAPE & REEL.

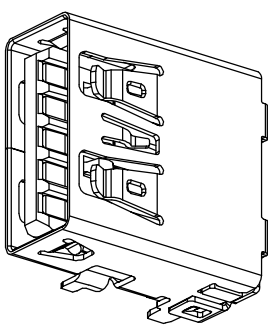

(SPRING MOTION HIGHEST POINT)
0.30 Max
2PLC

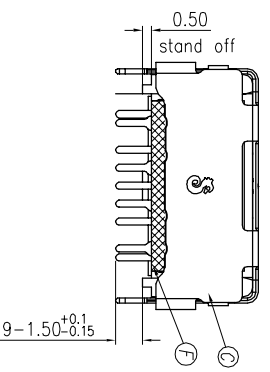
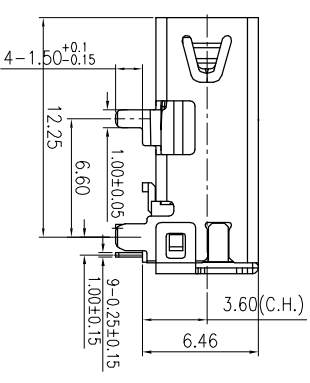
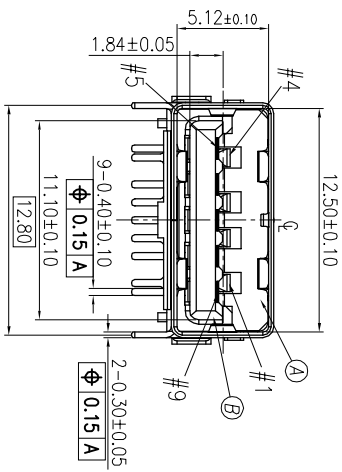
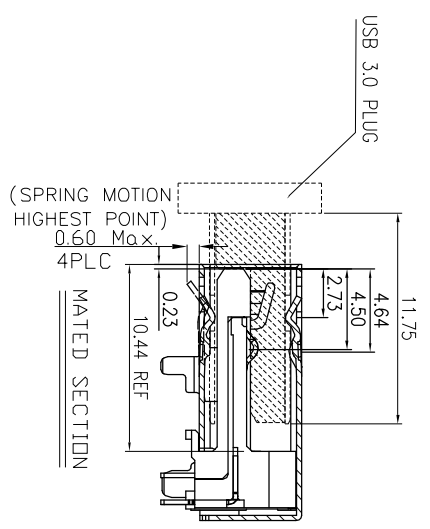
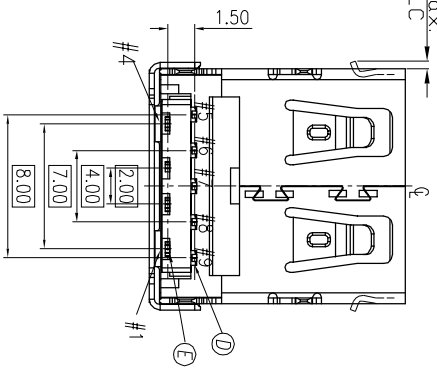

Pin NO.	Signal Assignment
# 1	VBUS
# 2	D-
# 3	D+
# 4	PGND
# 5	SSRX-
# 6	SSRX+
# 7	GND
# 8	SSTX-
# 9	SSTX+

F	MYLAR	1	MYLAR 0.075t	YELLOW
E	4P TERMINAL	4	PHOSPHOR BRONZE 0.25t	24V~49V/NSD* PLATED ON MATING AREA Note Sn 100% PLATED ON SOLDERING 50% NICKEL UNDER PLATING OVERALL
D	5P TERMINAL	5	PHOSPHOR BRONZE 0.25t	
C	SHELL	1	SUS304-1/2H 0.3t	NICKEL 60μ" MIN
B	HOUSING	1	PA9T+45%GF UL94V-0	YELLOW 810C
A	BASE	1	PA9T+45%GF UL94V-0	YELLOW 810C
NO	DESCRIPTION	QTY	MATERIAL	PLATING & COLOR

UNLESS OTHERWISE SPECIFIED TOLERANCES

Singatron Enterprise Co., Ltd.
信音企業股份有限公司

DECIMALS:	ANGLES:
X :±0.5	X :±2°
X.X :±0.3	X.X :±1°
X.XX :±0.2	
TITLE	USB3.1 REVERSE CONNECTOR
DWN	Edi-zhou PART NO. ZUB2310-015111F
CHKD	James SCALE 1:1 UNIT: mm
APVD	Boye SIZE: A3 SHEET: 10F1 REV: A

CUSTOMER COPY

