

REV.	ECN NO OR DESCRIPTION	REVISED	DATE
A	PRODUCT RELEASE	Stone	2017/05/25
D	ECN NO. S180301-R	Chensong	2018/03/08
E	ECN NO.S190914-C	ERIC	2020/04/27
F	ECN NO.S202007-C21	HAOLAN	2020/08/04

- ELECTRICAL CHARACTERISTICS:
 - 1-LLCR:
 - VBUS & GND PINS:40mΩ/PIN MAX.
 - OTHER PINS:40mΩ/PIN MAX.
 - LLCR MAX. CHANGE OF ALL PINS:10mΩ.
 - 2-CURRENT RATING:5.0A MAX.
 - 3-VOLTAGE RATING:20.0V
 - 4-INSULATION RESISTANCE:100MΩ MIN. BY 500V DC.
 - 5-ENVIRONMENTAL PERFORMANCE:
 - OPERATING TEMPERATURE:-55°C~+85°C
- MECHANICAL CHARACTERISTICS:
 - 2-1.INSERTION FORCE:0.5~2.0kg.
 - 2-2.WITHDRAWAL FORCE:0.8~2.0kg (INITIAL 10,000 CYCLES)0.6~2.0kg (AFTER LIFE TEST)
- DURABILITY:10,000CYCLES
- TO CONFORM TO THE SINGATRON HAZARDOUS SUBSTANCE FREE SPEC.
- HALOGEN FREE PRODUCT IDENTIFICATION LABEL ON PACKAGING:
- PACKAGE:SEE"2UB2C02-007111F"PACKAGE.
- FOR REFLOW SOLDERING LEAD-FREE PROCESS
- OTHER GENERAL SPEC.TO REFER"2UB2C02 SPEC."

PIN ASSIGNMENTS:

PIN No.	SIGNAL NAME	PIN NUMBER
A1	GND	B12
A2	SSTXp1	B11
A3	SSTXn1	B10
A4	Vbus	B9
A5	CC1/CC2	B8
A6	Dp1/Dp2	B7
A7	Dn1/Dn2	B6
A8	RFU1/RFU2	B5
A9	Vbus	B4
A10	SSRXn2	B3
A11	SSRXp2	B2
A12	GND	B1

F	GND RING	1	SUS301 3/4H T=0.20	
E	GND PLATE	1	SUS301 1/2H T=0.20	
D	COVER	1	SUS304 1/2H T=0.20	NICKEL 60u" Min PLATING
C	SHELL	1	SUS304 1/2H T=0.20	NICKEL 60u" Min PLATING
B	TERMINAL	24	C7035 T=0.12	AU 30u"ON CONTACT AREA MATT TIN 75u"Min ON SOLDER AREA ALL OVER NICKEL 80u"Min PLATING
A	HOUSING	1	LCP E130I UL 94V-0	BLACK

NO.	DESCRIPTION	QTY	MATERIAL	PLATING & COLOR
UNLESS OTHERWISE SPECIFIED TOLERANCES				
Singatron Enterprise Co., Ltd. 				
DECIMALS:		ANGLES:		TITLE
X	:±0.5	X	:±2°	CONN USB3.1CONN USB3.1C 24P CH=2.4
X.X	:±0.3	X.X	:±1°	DWN HAOLAN PART NO.: 2UB2C02-007111F
X.XX	:±0.2	CHKD boye SCALE 1:1 UNIT: mm		
APVD liao			SIZE: A3	SHEET: 1 OF2 REV: F
CUSTOMER COPY				

REV.	ECN NO OR DESCRIPTION	REVISED	DATE
A	PRODUCT RELEASE	Stone	2017/05/25
D	ECN NO. S180301-R	Chensong	2018/03/08
E	ECN NO.S190914-C	ERIC	2020/04/27
F	ECN NO.S202007-C21	HAOLAN	2020/08/04

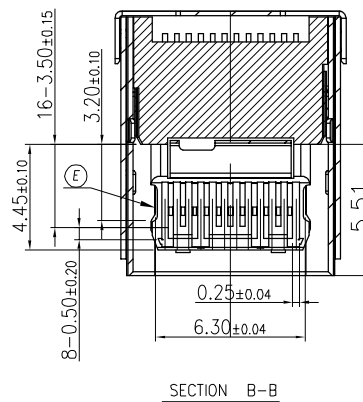
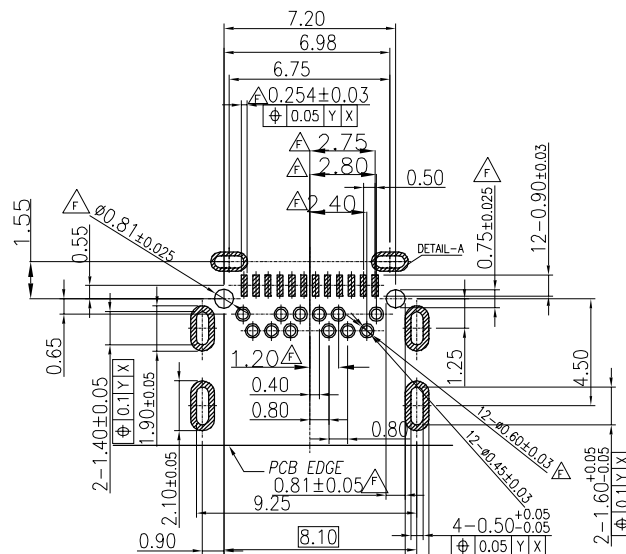

PIN ASSIGNMENTS:

PIN No.	SIGNAL NAME	PIN NUMBER
A1	GND	B12
A2	SSTXp1	B11
A3	SSTXn1	B10
A4	Vbus	B9
A5	CC1/CC2	B8
A6	Dp1/Dp2	B7
A7	Dn1/Dn2	B6
A8	RFU1/RFU2	B5
A9	Vbus	B4
A10	SSRXn2	B3
A11	SSRXp2	B2
A12	GND	B1

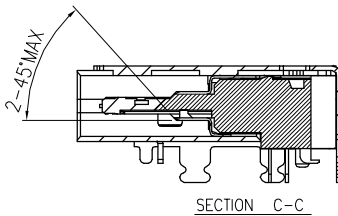
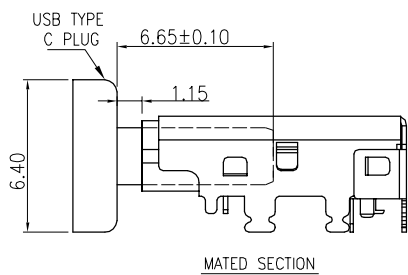

F	GND RING	1	SUS301 3/4H T=0.20	
E	GND PLATE	1	SUS301 1/2H T=0.20	
D	COVER	1	SUS304 1/2H T=0.20	NICKEL 60u" Min PLATING
C	SHELL	1	SUS304 1/2H T=0.20	NICKEL 60u" Min PLATING
B	TERMINAL	24	C7035 T=0.12	AU 30u"ON CONTACT AREA MATT TIN 75u"Min ON SOLDER AREA ALL OVER NICKEL 80u"Min PLATING
A	HOUSING	1	LCP E130I UL 94V-0	BLACK

NO.	DESCRIPTION	QTY	MATERIAL	PLATING & COLOR
UNLESS OTHERWISE SPECIFIED TOLERANCES				
		Singatron Enterprise Co., Ltd. 信音企業股份有限公司		
DECIMALS:		TITLE		
ANGLES:		CONN USB3.1CONN USB3.1C 24P CH=2.4		
X : ±0.5	X : ±2°	DWN	HAOLAN	PART NO.: 2UB2C02-00711F
X.X : ±0.3	X.X : ±1°	CHKD	boye	SCALE 1:1 UNIT: mm
X.XX : ±0.2		APVD	liao	SIZE: A3 SHEET: 2 OF 2 REV: F
CUSTOMER COPY				