

STANDOFF OFF, NO TRACE IN THE AREA
 RECOMMENDED P.C.B. LAYOUT
 TOLERANCE (TOP VIEW) ±0.05mm

SPECIFICATIONS:

- ELECTRICAL CHARACTERISTICS:
 - CURRENT RATING: 2.0A (PIN1,4) ; OTHER CONTACTS 0.25A
 - CONTACT RESISTANCE: 30mΩ MAX.(INITIAL),40mΩ(AFTER LIFE TEST)
 - DIELECTRIC WITHSTANDING VOLTAGE: 500V AC FOR 1 MINUTE
 - INSULATION RESISTANCE: 100MΩ MIN. MEASURED BY 500 VDC.
- MECHANICAL CHARACTERISTICS:
 - INSERTION FORCE : 35N MAX. INITIAL.
 - WITHDRAWAL FORCE : 9.8N MIN INITIAL, 8N MIN, FOR AFTER TEST.
- LIFE TEST: 5000 CYCLES
- OPERATING TEMPERATURE:-55~+85C
- OTHER GENERAL SPEC TO REFER "2UB2Y11-310211F_SPEC"
- TO CONFORM TO SINGATRON HAZARDOUS SUBSTANCE FREE SPEC.
- HALOGEN FREE PRODUCT IDENTIFICATION MARK : Ⓞ
- HALOGEN FREE PRODUCT IDENTIFICATION LABEL ON PACKAGING:
- FOR IR REFLOW ROFILE,PEAK TEMPERATURE:260°C MAX.;10SECS.
- PACKAGING : TRAY.

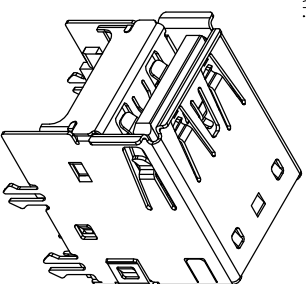
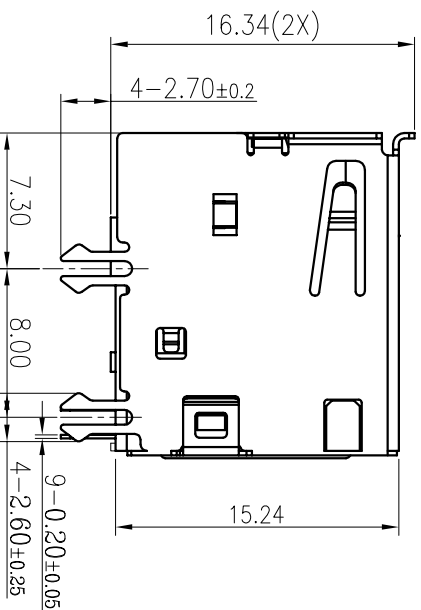
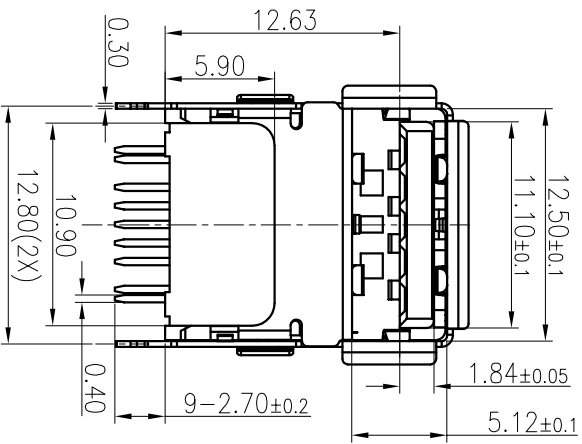

F	BACK SHELL	1	SUS	CLEANING
E	FRONT SHELL	1	SUS	WAVE TIN ON SOLDER TAIL GAL OVER NICKEL PLATING
C	USB2.0 CONTACT	4	C5191	
B	USB3.0 CONTACT	5	C2680	Has 15.2 mm ON CONTACT AREA WAVE TIN 500 MIN. ON SOLDER TAIL NICKEL 500 MIN. UNDER PLATED
A	I/M HOUSING	1	PA66 UL94V-0	BLUE 300C
A	HOUSING	1	PA66 UL94V-0	BLUE 300C
NO	DESCRIPTION	QTY	MATERIAL	PLATING & COLOR
UNLESS OTHERWISE SPECIFIED TOLERANCES				
TITLE		USB3.1 CONNECTOR		
DWN		Ye Wei		
CHKD		Jim-Deng		
APVD		Jim-Deng		

Singatron Enterprise Co., Ltd.
信晉企業股份有限公司

DECIMALS:	ANGLES:	TITLE		USB3.1 CONNECTOR	
X : ±0.5	X : ±2°	DWN		Ye Wei	
X.X : ±0.3	X.X : ±1°	CHKD		Jim-Deng	
X.XX : ±0.2		APVD		Jim-Deng	
		SCALE	1:1	UNIT:	mm
		SIZE:	A3	SHEET:	10F1
		REV:	A		

CUSTOMER COPY