

REV.	ECN NO OR DESCRIPTION	REVISED	DATE
A	PRODUCED RELEASED	Robin He	2011.03.17

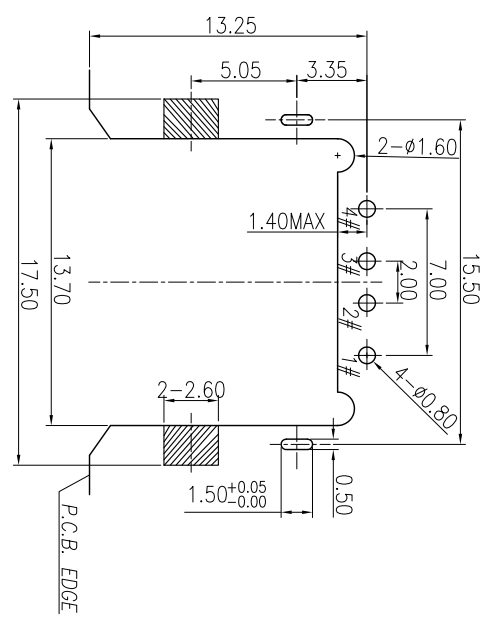

RECOMMENDED P.C.B. LAYOUT (Component Side)
TOP VIEW (TOLERANCE: ±0.05)

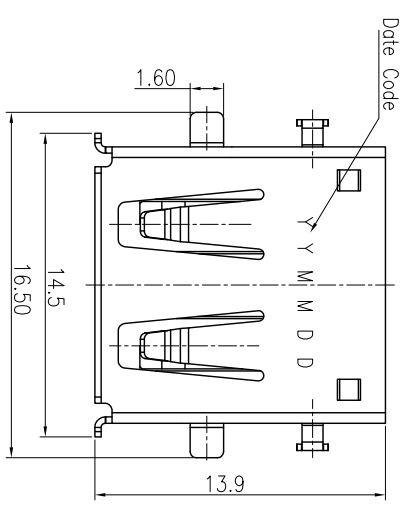
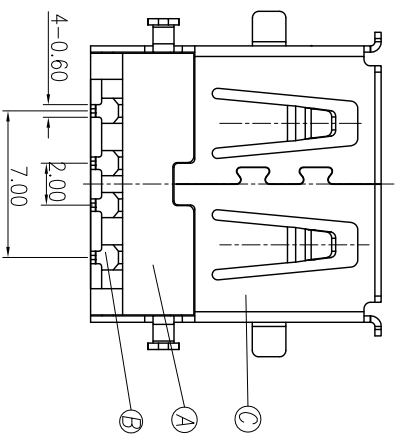
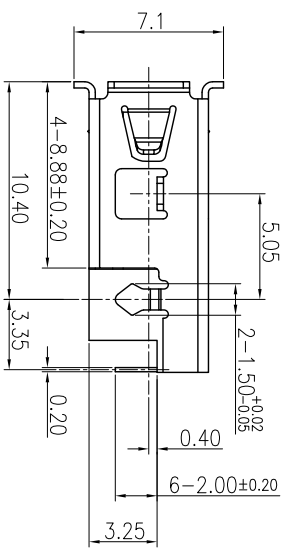
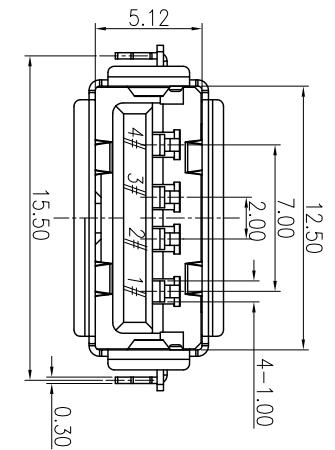

- SPECIFICATION**
- 1. ELECTRICAL CHARACTERISTICS:**
- 1-1. VOLTAGE & CURRENT RATING: DC 30V MAX & 1.5A
 - 1-2. CONTACT RESISTANCE: 30mΩ MAX.
 - 1-3. INSULATION RESISTANCE: 1000MΩ MIN.
 - 1-4. DIELECTRIC WITHSTAND: 500V AC for 1 MINUTE
 - 1-5. OPERATING TEMPERATURE: -55°C ~ +85°C
- 2. MECHANICAL CHARACTERISTICS:**
- 2-1. INSERT FORCE: 35N MAX.
 - 2-2. WITHDRAW FORCE: 8N MIN.
- 3. LIFE TEST: 5000 CYCLES**
- 4. OTHER GENERAL SPEC. TO REFER "2UB2Y** SERIES SPEC"**
- 5. PACKING: TAPE & REEL**
- 6. HALOGEN FREE PRODUCT IDENTIFICATION LABEL ON PACKAGING:**
- 7. PRODUCT NO:**

2UB2Y31-0 0 0 1 1 1 F

HOUSING MATERIAL
0 = HIGH TEMP

CONTACT PLATING
00 = G/F

DURABILITY
1 = 5000 CYCLES

HALOGEN CODE
F = HALOGEN FREE

PACKAGE TYPE
1 = TAPE & REEL

REAR SHELL TYPE
1 = W/O REAR SHELL

C	SHELL	1	STEEL 0.30t	PLATING NICKEL
B	CONTACT	4	COPPER ALLOY 0.2t	GOLD FLASH
A	Housing	1	HIGH TEMP-THERMOPLASTIC	BLACK
NO	DESCRIPTION	QTY	MATERIAL	PLATING & COLOR
UNLESS OTHERWISE SPECIFIED TOLERANCES				
Singatton Enterprise Co., Ltd. 信音企業股份有限公司				
TITLE		USB A/F DIP 90°DEEP TYPE(H=0.40)		
DWN	RobIn	PART NO.	2UB2Y31-000111F	
CHKD	Tony	SCALE	4:1	UNIT: mm
APVD	Seon-L	SIZE:	A3	SHEET: 1 OF 1
DECIMALS:		ANGLES:		
X	:±0.5	X	:±2°	
X.X	:±0.3	X.X	:±1'	
X.XX	:±0.2			

CUSTOMER COPY