

Hosiden Corporation NO:
WMS1421-010011

REV.	ECN NO OR DESCRIPTION	REVISED	DATE
A	PRODUCT RELEASE	LONGJIANG	2017.05.09

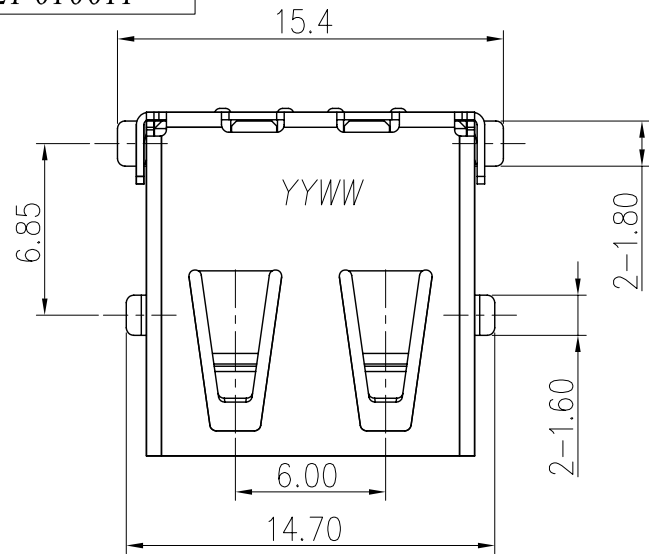

YYWW
Year
Week

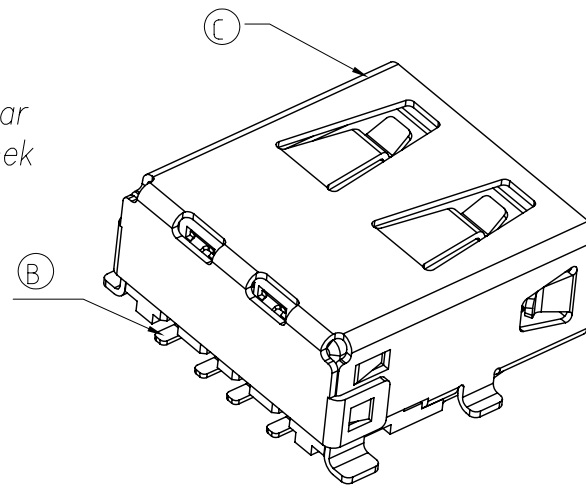

SPECIFICATION

- ELECTRICAL CHARACTERISTICS:
 - VOLTAGE & CURRENT RATING: DC 30V MAX. & 1.5A
 - CONTACT RESISTANCE: 30mΩ MAX.
 - INSULATION RESISTANCE: 1,000MΩ MIN. BY 500V DC.
 - DIELECTRIC WITHSTAND: 500V AC FOR 1 MINUTE.
- MECHANICAL CHARACTERISTICS:
 - INSERT FORCE: 35N MAX.
 - WITHDRAW FORCE: 10N MIN.
 - LIFE TEST : 5,000 CYCLES
- OTHER GENERAL SPEC. TO REFER "2UB2Y64 SERIES SPEC"
- HALOGEN FREE PRODUCT IDENTIFICATION MARK ON PRODUCT: Ⓢ
- HALOGEN FREE PRODUCT IDENTIFICATION LABEL ON PACKAGING: Ⓢ
- FOR REFLOW SOLDERING LEAD-FREE PROCESS
- PACKING: TAPE & REEL.

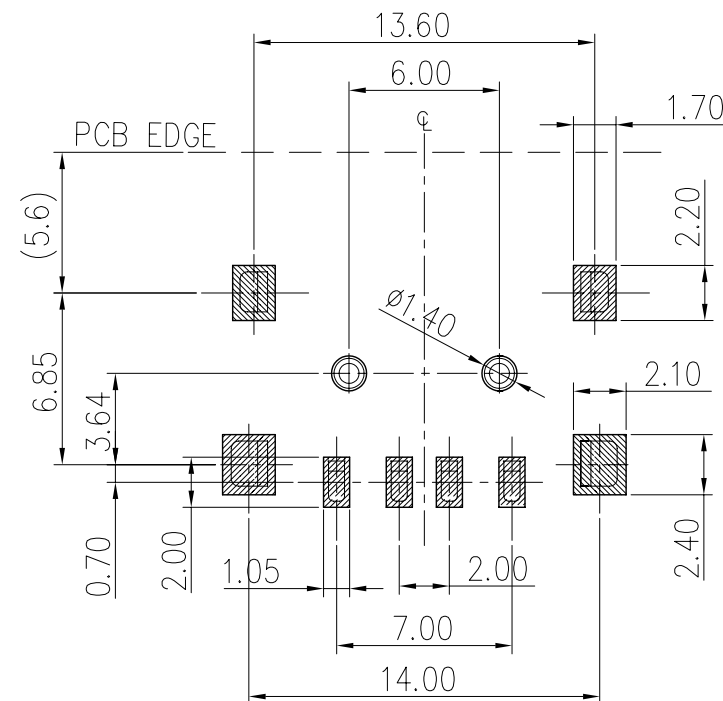
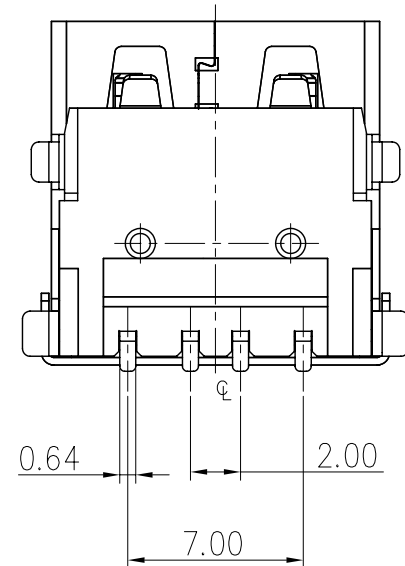
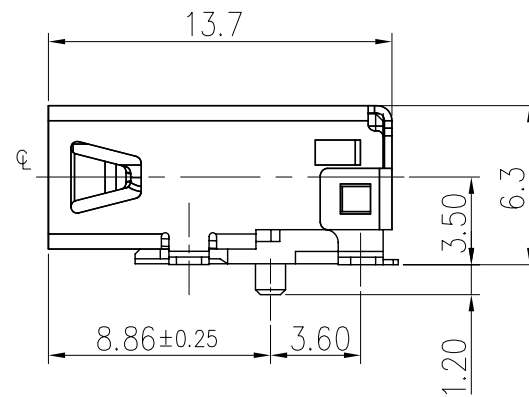
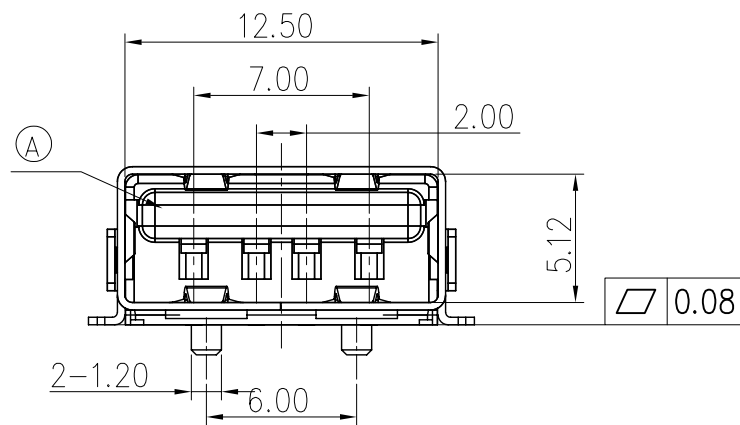

RECOMMENDED P.C.B. LAYOUT
TOP VIEW (TOLRANCE: ±0.05)

NO	DESCRIPTION	QTY	MATERIAL	PLATING & COLOR
C	SHELL	1	STAINLESS STEEL 0.30T	GOLD FLASH ON SOLDER TAIL ALL OVER NICKEL PLATING.
B	CONTACT	4	COPPER ALLOY 0.20T	GOLD FLASH ON CONTACT AREA, AND 120u" TIN ON SOLDER TAIL ALL OVER 60u" MIN. PLATING.
A	HOUSING	1	HIGH TEMP. THERMOPLASTIC UL 94V-0	BLACK

UNLESS OTHERWISE
SPECIFIED TOLERANCES

Singatron Enterprise Co., Ltd.
信音企業股份有限公司

DECIMALS: ANGLES:
X : ±0.5 X : ±2°
X.X : ±0.3 X.X : ±1°
X.XX : ±0.2

TITLE	USB 2.0 AF SMT TYPE		
DWN	Longjiang-Cao 17/05/11	PART NO. 2UB2Y64-003111F	
CHKD	Justin-Kuo 17/05/11	SCALE : 1	UNIT: mm
APVD	Max-Mai 17/05/11	SIZE: A3	SHEET: 1 OF 1

CUSTOMER COPY