

REV	ECON NO	OR DESCRIPTION	REVISED	DATE
A	PRODUCT	RELEASE	LONGJIANG	2014.12.11

1. ELECTRICAL CHARACTERISTICS:
- CURRENT RATING: 1.5A  
WORKING RATED VOLTAGE: 30V DC
  - CONTACT RESISTANCE: 30mΩ MAX INITIAL.
  - DIELECTRIC WITHSTANDING VOLTAGE: 500V AC FOR ONE MINUTE.
  - INSULATION RESISTANCE: 1000MΩ MIN. MEASURED BY 500 VDC
2. MECHANICAL CHARACTERISTICS:
- INSERTION FORCE : 35N MAX.
  - WITHDRAWAL FORCE : 10N MIN.
  - LIFE TEST: 5000 CYCLES MIN.
  - PACKING: TAPE & REEL
  - OTHER GENERAL SPEC. TO REFER "2UB2Y73 SERIES SPEC".
  - HALOGEN FREE PRODUCT IDENTIFICATION LABEL ON PACKAGING: 

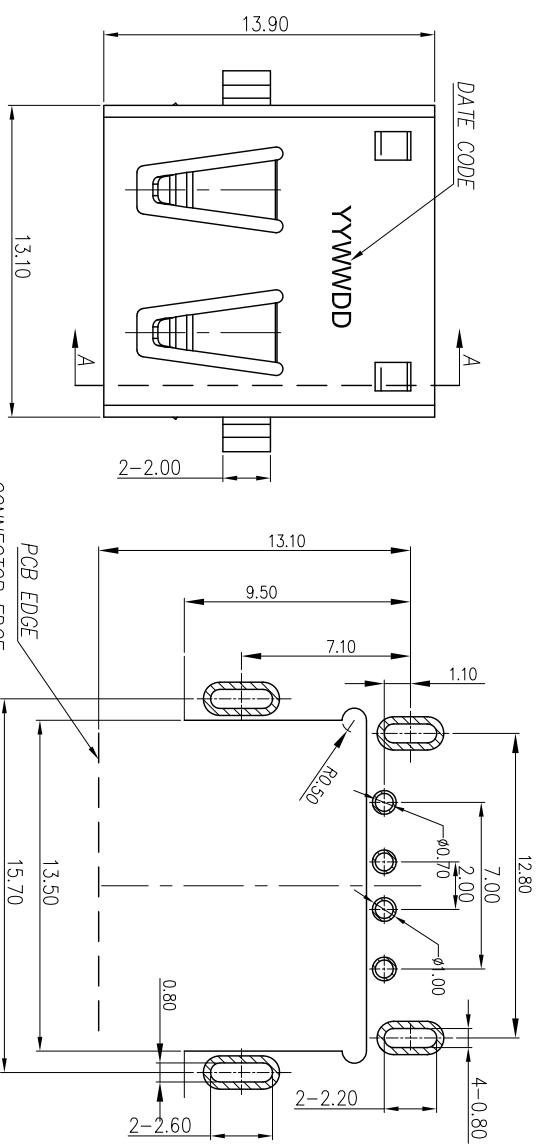

Recommend PCB Layout (Top View)  
Tolerance: ±0.05mm Thickness: 1.2mm

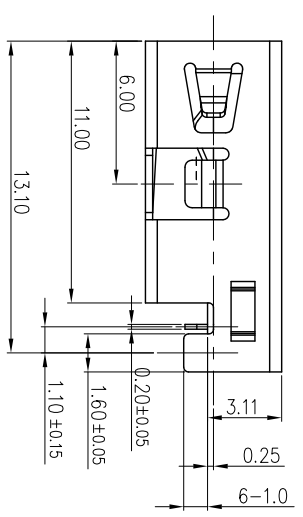
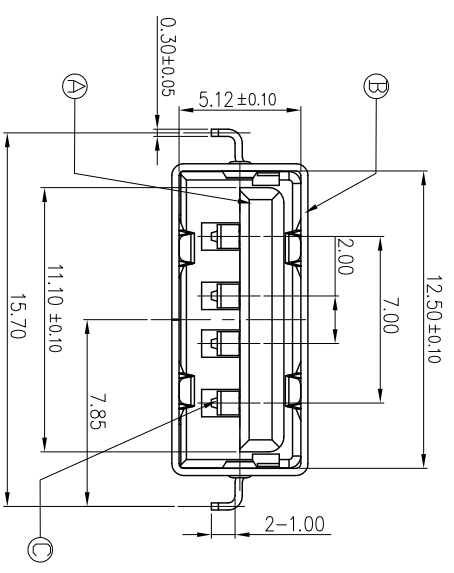
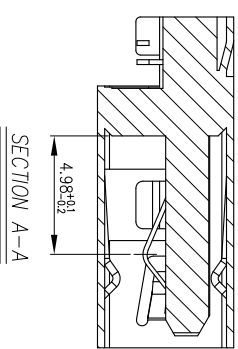

C	CONTACT	4	COPPER ALLOY	Au 30μ" PLATED ON CONTACT AREA SW PLATED ON SOLDER TAIL ALL OVER NI PLATED
B	SHELL	1	STEEL	PLATING NI
A	HOUSING	1	HIGH THERMOPLASTIC UL 94V-0	BLACK
NO	DESCRIPTION	QTY	MATERIAL	PLATING & COLOR

UNLESS OTHERWISE SPECIFIED TOLERANCES

 Singtong Enterprise Co., Ltd.  
信亨企業股份有限公司

TITLE	USB 2.0 AF CONNECTOR
DWG	songling 14/12/15
CHKD	tz 14/12/15
APVD	max 14/12/15
SCALE	N/A
UNIT	mm
SIZE	A3
SHEET	10F1
REV.	A

DECIMALS: ANGLES: X : ±0.5 X : ±2°  
X X : ±0.3 X X : ±1°  
X XX : ±0.2

CUSTOMER COPY

