

REV.	ECN NO OR DESCRIPTION	REVISED	DATE
A	PRODUCT RELEASE	Longjiang	2016/5/26

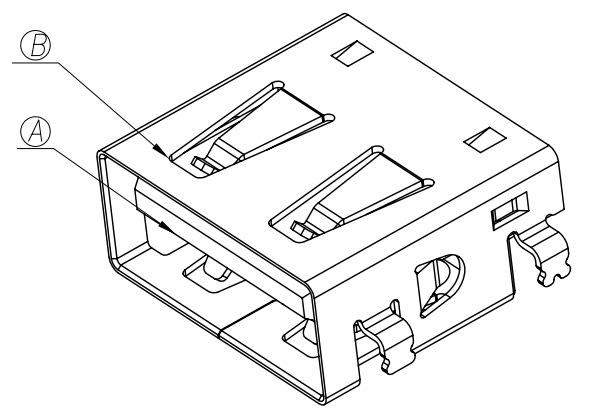

SPECIFICATION

- ELECTRICAL CHARACTERISTICS:**
 - CONTACT RESISTANCE: 30mΩ MAX.
 - VOLTAGE & CURRENT RATING: DC 30V MAX. & 1.5A
 - INSULATION RESISTANCE: 1,000 MEGOHMS BY 500V DC.
 - DIELECTRIC WITHSTAND: 500V AC for 1 MINUTE
 - OPERATING TEMPERATURE: -55°C~+85°C
- MECHANICAL CHARACTERISTICS:**
 - INSERT FORCE: 35N MAX.
 - WITHDRAW FORCE: 10N MIN.
 - LIFE TEST :1,500 CYCLES
- OTHER GENERAL SPEC. TO REFER "2UB2Y73-005211F SPEC."
- HALOGEN FREE PRODUCT IDENTIFICATION MARK :⊙
- HALOGEN FREE PRODUCT IDENTIFICATION LABEL ON PACKAGING:
- FOR REFLOW SOLDERING LEAD-FREE PROCESS
- PACKING: TAPE & REEL

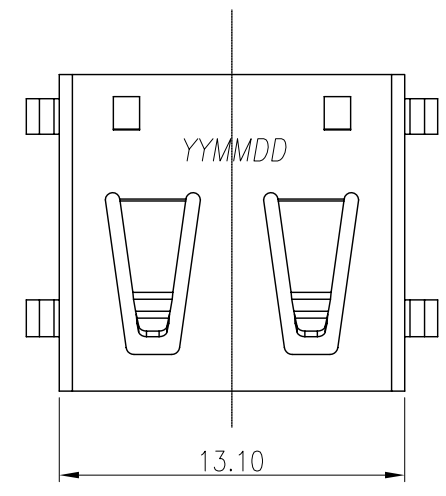
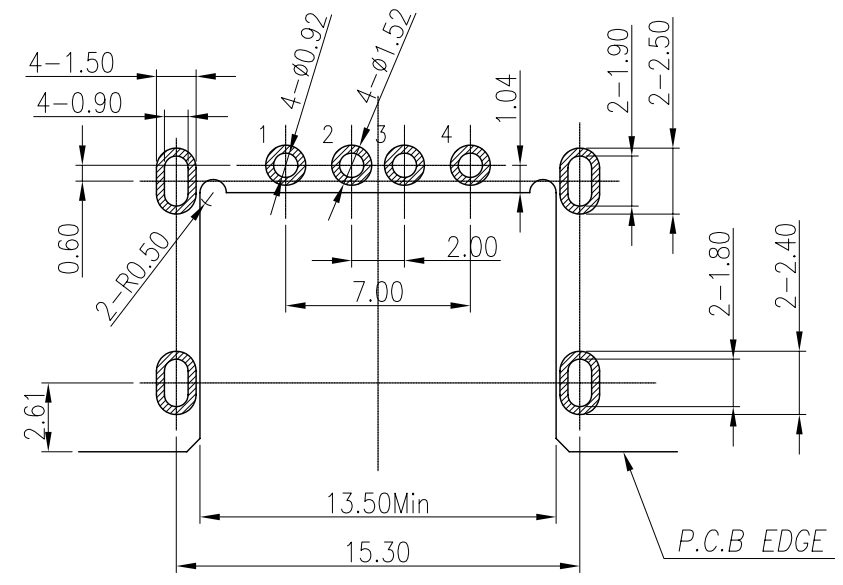
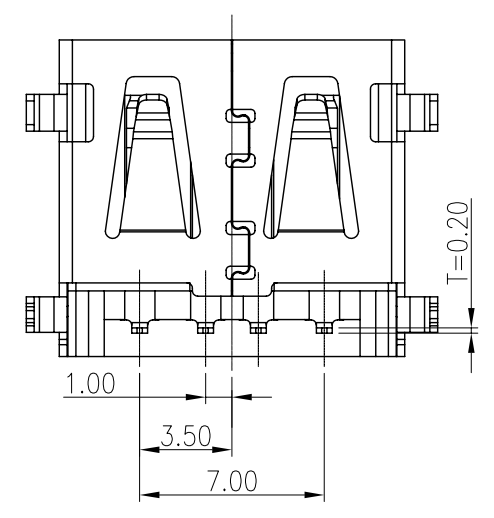
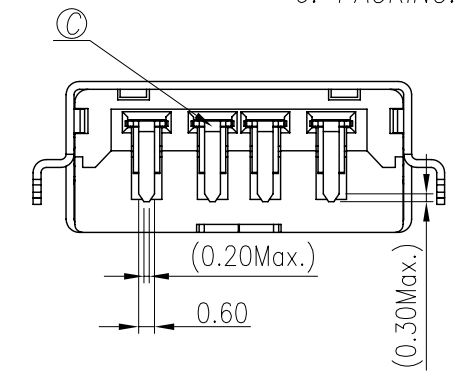
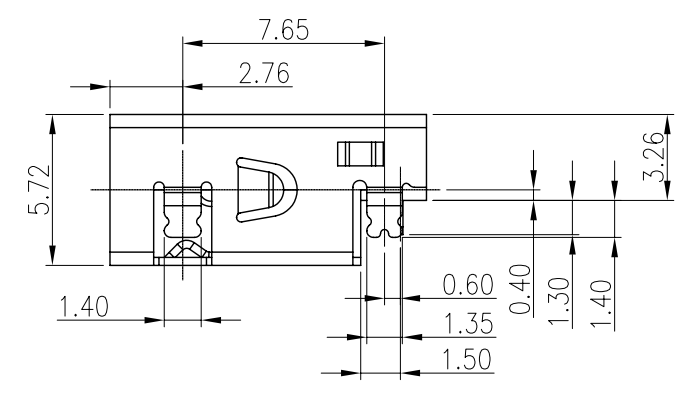
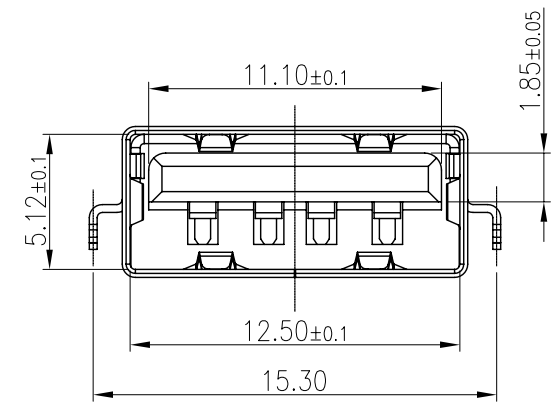

RECOMMENDED P.C.B. LAYOUT
TOLERANCE (TOP VIEW) ±0.05mm

C	CONTACT	4	COPPER ALLOY	G/F+30u"P/d NI ON CONTACT AREA AND TIN ON SOLDER TAIL, ALL OVER NICKEL PLATING
B	SHELL	1	STAINLESS STEEL	NICKEL PLATING
A	HOUSING	1	HIGH TEMP. THERMOPLASTIC UL 94V-0	BLACK
NO	DESCRIPTION	QTY	MATERIAL	PLATING & COLOR

UNLESS OTHERWISE SPECIFIED TOLERANCES		Singatron Enterprise Co., Ltd. 信音企業股份有限公司		
DECIMALS:	ANGLES:	TITLE	USB A/F DIP 90° TYPE	
X :±0.5	X :±2°	DWN	Longjiang-Cao 16/05/30	PART NO.2UB2Y73-005211F
X.X :±0.3	X.X :±1°	CHKD	Yan-Zhang 16/05/30	SCALE 4:1 UNIT: mm
X.XX :±0.2		APVD	Justin-Kuo 16/05/30	SIZE: A3 SHEET: 10F1 REV: A
CUSTOMER COPY				