

REV.	ECON NO	OR DESCRIPTION	REVISED	DATE
A	NEW	RELEASE	ZW	2012.11.20

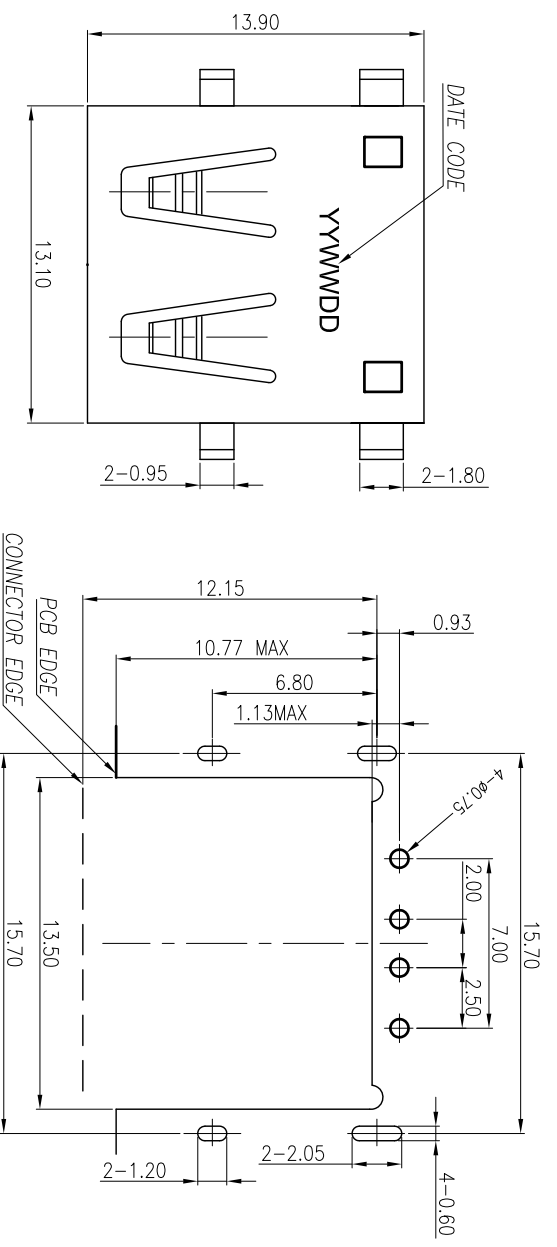

Recommend PCB Layout (Top View)
Tolerance: ±0.05mm Thickness: 1.2mm

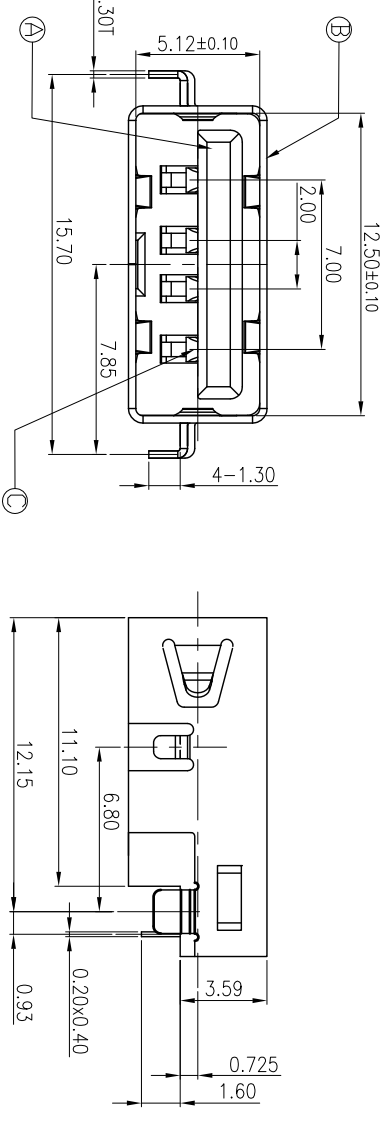

1. ELECTRICAL CHARACTERISTICS:
- CURRENT RATING: 1.5A
WORKING RATED VOLTAGE: 30V DC
 - CONTACT RESISTANCE: 30mΩ MAX INITIAL
 - DIELECTRIC WITHSTANDING VOLTAGE: 500V AC FOR ONE MINUTE.
 - INSULATION RESISTANCE: 1000MΩ MIN. MEASURED BY 500 VDC
2. MECHANICAL CHARACTERISTICS:
- INSERTION FORCE : 35N MAX
 - WITHDRAWAL FORCE : 10N MIN
 - LIFE TEST: 5000 CYCLES MIN.
 - PACKING: TAPE REEL
 - OTHER GENERAL SPEC. TO REFER "2UB2Y73 SERIES SPEC."
 - HALOGEN FREE PRODUCT IDENTIFICATION LABEL ON PACKAGING:
 - PRODUCT NO: 2UB2Y73-2 0 0 2 1 1 F

USB TYPE _____ HALOGEN CODE _____
 2=USB 2.0 _____ F=HALOGEN FREE
 CONTACT PLATING _____ PACKAGE TYPE _____
 00=GOLD FLASH _____ 1=TAPE REEL
 SHELL TYPE _____ HOUSING MATERIAL _____
 2=WITHOUT BACK SHELL _____ 1=HIGH TEMP PLASTIC

NO	DESCRIPTION	QTY	MATERIAL	PLATING & COLOR
C	CONTACT	4	COPPER ALLOY	G/PLATED ON CONTACT AREA S/N PLATED ON SOLDER TAIL ALLOYER N/PLATED
B	SHELL	1	STEEL	PLATING NIL
A	HOUSING	1	HIGH THERMOPLASTIC U95A-0	BLACK

UNLESS OTHERWISE SPECIFIED TOLERANCES

Singaton Enterprise Co., Ltd.
信晉企業股份有限公司

DECIMALS:	ANGLES:	TITLE	USB 2.0 AF CONNECTOR
X : ±0.5	X : ±2°	DWN	ZW
X.X : ±0.3	X.X : ±1°	CHKD	KIM
X.XX : ±0.2		APVD	SEAN

PART NO. 2UB2Y73-200211F
SCALE N/A UNIT: mm
SIZE: A3 SHEET: 10F1 REV: A