

REV.	ECN NO OR DESCRIPTION	REVISED	DATE
A	PRODUCT RELEASE	Ted	2018/12/18

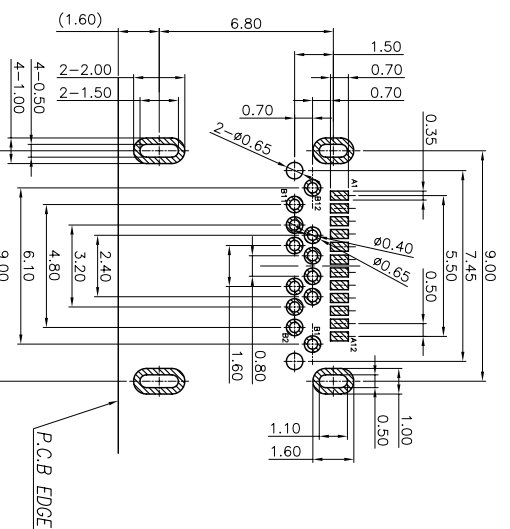
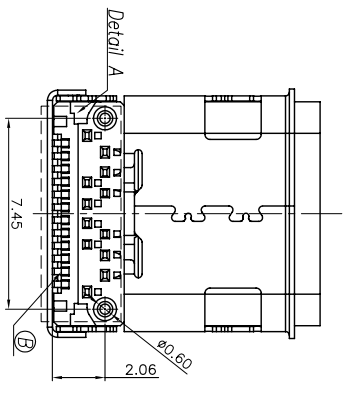
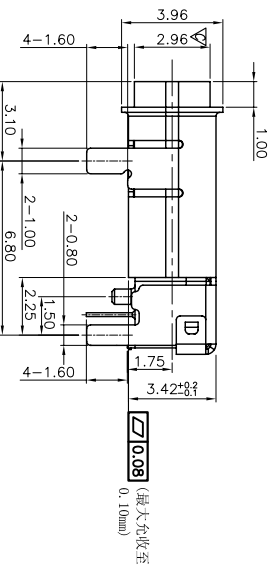
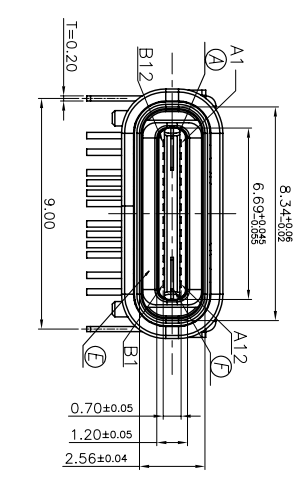
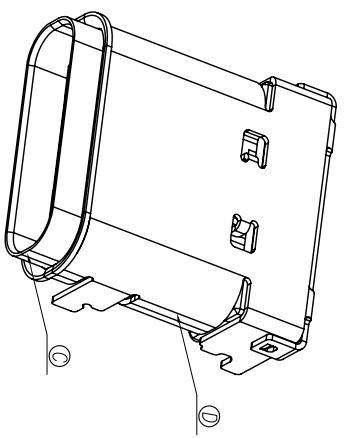
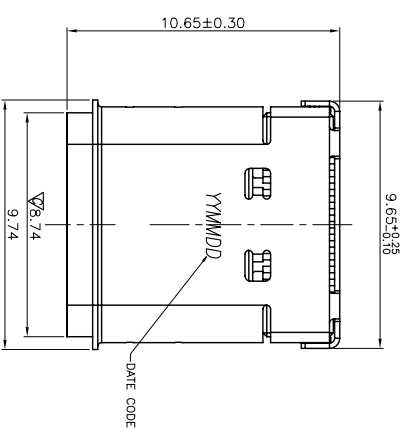

- SPECIFICATIONS:**
- 1. ELECTRICAL CHARACTERISTICS:**
- 1-1. RATING: 5A FOR VBUS, 1.25A FOR GND, PIN.0, 25A FOR OTHER PIN.
 - 1-2. CONTACT RESISTANCE: 40mΩ MAX.
 - 1-3. INSULATION RESISTANCE: 100 MEGAΩHMS MIN. BY 100V DC.
 - 1-4. DIELECTRIC WITHSTANDING VOLTAGE: 100V AC FOR 1 MINUTE.
- 2. MECHANICAL CHARACTERISTICS:**
- 2-1. INSERTION FORCE: 5~20N
 - 2-2. WITHDRAWAL FORCE: 8N~20N (INITIAL); 6~20N (AFTER LIFE TEST)
- 3. LIFE TEST: 10,000 CYCLES.**
- 4. OTHER GENERAL SPEC. TO REFER "2UB2Y08-C00111F SPEC".**
- 5. TO CONFORM TO SINGATRON HAZARDOUS SUBSTANCE FREE SPEC.**
- 6. HALOGEN FREE PRODUCT IDENTIFICATION MARK ON PRODUCT:**
- 7. HALOGEN FREE PRODUCT IDENTIFICATION LABEL ON PACKAGING:**
- 8. WATER PROOF: FOR IPX7**
- 9. FOR REFLOW SOLDERING LEAD-FREE PROCESS. & THE O-RING CAN NOT GO THROUGH THE IR PROCESS WITH WATERPROOF CONNECTOR TOGETHER.**

G	O-RING	1	BLACK
F	GND RING	1	STAINLESS STEEL
E	GND PLATE	1	STAINLESS STEEL
D	COVER	1	NICKEL PLATING
C	SHELL	1	STAINLESS STEEL
B	TERMINAL	24	COPPER ALLOY
A	HOUSING	1	HIGH TEMP. THERMOPLASTIC
NO	DESCRIPTION	QTY	MATERIAL
UNLESS OTHERWISE SPECIFIED TOLERANCES			
TITLE: USB TYPE-C CONNECTOR			
DWN: 18/12/26			
CHKD: 18/12/26			
APVD: 18/12/26			
PART NO. 2UB2Y80-C00111F			
SCALE 3:1			
UNIT: mm			
SHEET: 10F2			
REV: A			
CUSTOMER COPY			

Singatron Enterprise Co., Ltd.

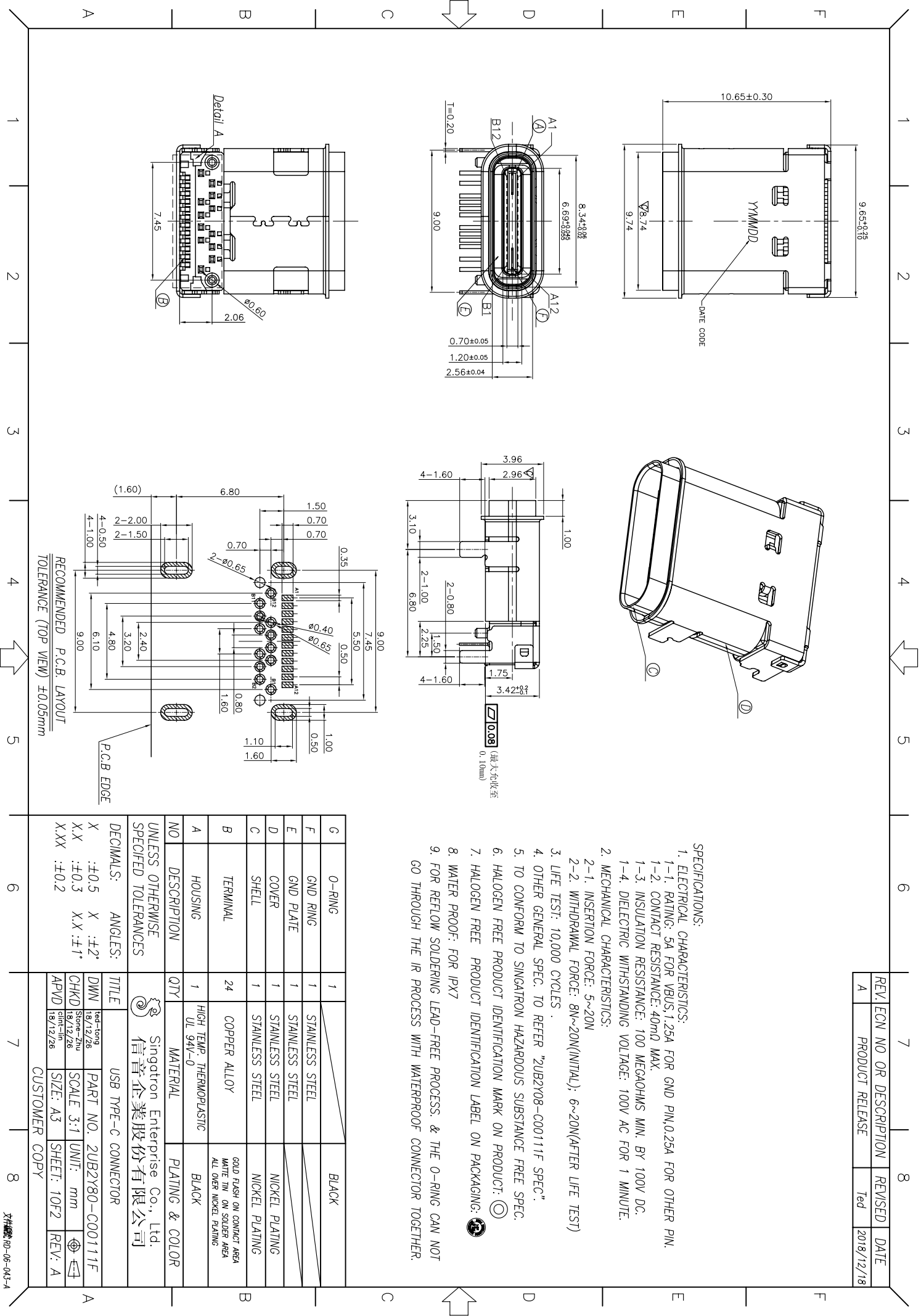

REV. ECN NO. OR DESCRIPTION	REVISED	DATE
A PRODUCT RELEASE	Ted	2018/12/18

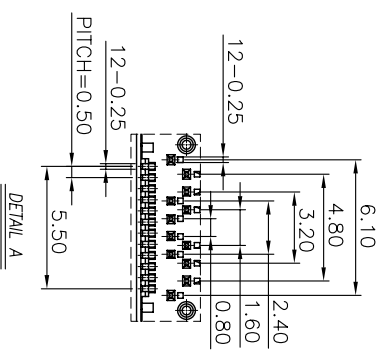
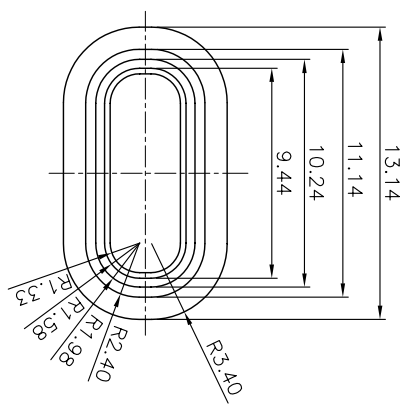
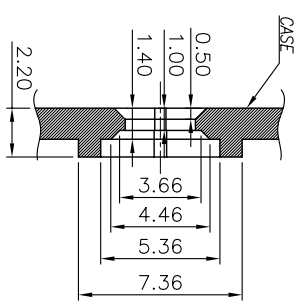
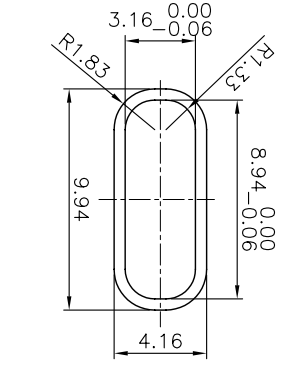
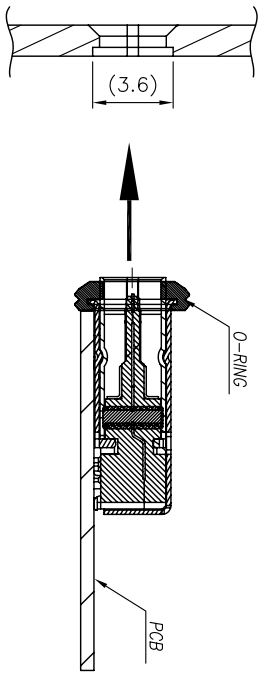

THE COMPRESSION BETWEEN COVER AND SEALING RING IS 0.3mm MIN.
SUGGESTED COMPRESSION:35-45% OF SEALING RING'S DIAMETER

THE COMPRESSION BETWEEN COVER AND SEALING RING IS 0.3mm MIN.
SUGGESTED COMPRESSION:35-45% OF SEALING RING'S DIAMETER

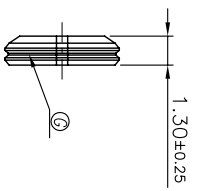
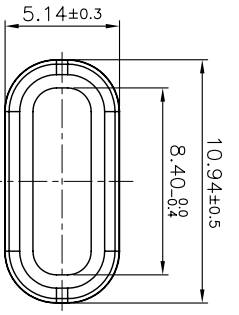
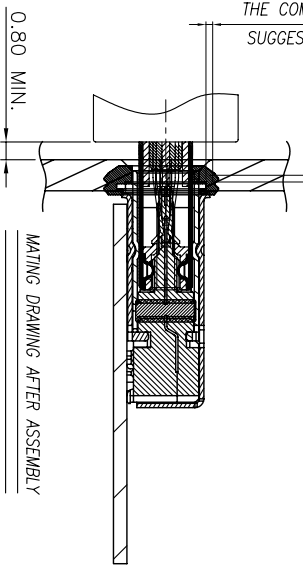

O-RING

RECOMMENDED OPEN DIMENSION OF CASE
TOLERANCE:±0.03mm
MATTING AREA WITH SEALING RING

PIN ASSIGNMENTS:

PIN No.	SIGNAL NAME	PIN NUMBER
A1	GND	B12
A2	SSTxp1	B11
A3	SSTxn1	B10
A4	Vbus	B9
A5	CC1/SBU2	B8
A6	Dp1/Dp2	B7
A7	Dn1/Dn2	B6
A8	SBU1/CC2	B5
A9	Vbus	B4
A10	SSRxp2	B3
A11	SSRxp2	B2
A12	GND	B12

NO	DESCRIPTION	QTY	MATERIAL	PLATING & COLOR
UNLESS OTHERWISE SPECIFIED TOLERANCES				
DECIMALS: ANGLES:				
X	±0.5	X	±2°	
X.X	±0.3	X.X	±1°	
X.XX	±0.2			
TITLE	USB TYPE-C CONNECTOR			
DWN	18/12/26	PART NO.	2UB2Y80-C00111F	
CHKD	18/12/26	SCALE	3:1	
APVD	18/12/26	SIZE:	A3	
		SHEET:	20F2	
		REV:	A	

CUSTOMER COPY