

REV.	ECN NO OR DESCRIPTION	REVISED	DATE
A	PRODUCT RELEASE	Longjiang	17.05.09
B	ECN NO.:C190310 客户需求加严尺寸管控	Cheney	19.04.19

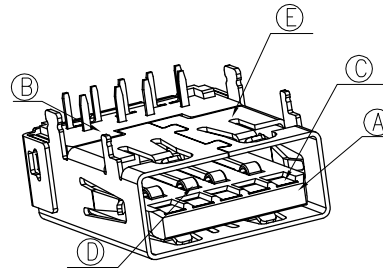

SPECIFICATIONS:

- ELECTRICAL CHARACTERISTICS:
 - CURRENT RATING: 1.8A (PIN1,4) ; OTHER CONTACTS 0.25A
 - CONTACT RESISTANCE: 30mΩ (INITIAL)MAX.
 - DIELECTRIC WITHSTANDING VOLTAGE: 500V AC FOR 1 MINUTE
 - INSULATION RESISTANCE: 100MΩ MIN. MEASURED BY 500 VDC.
- MECHANICAL CHARACTERISTICS:
 - INSERTION FORCE : 35N MAX. INITIAL.
 - WITHDRAWAL FORCE : 9.8N MIN. INITIAL, 8N MIN. FOR AFTER TEST.
- LIFE TEST: 5,000 CYCLES
- OTHER GENERAL SPEC TO REFER "2UB2Y90 SERIES SPEC"
- TO CONFORM TO SINGATRON HAZARDOUS SUBSTANCE FREE SPEC.
- HALOGEN FREE PRODUCT IDENTIFICATION MARK : ☉
- HALOGEN FREE PRODUCT IDENTIFICATION LABEL ON PACKAGING:
- FOR IR REFLOW ROFILE, PEAK TEMPERATURE: 260°C MAX. 10SECS.
- PACKAGING : TAPE & REEL.

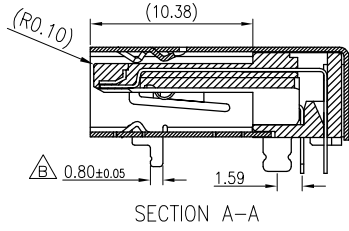
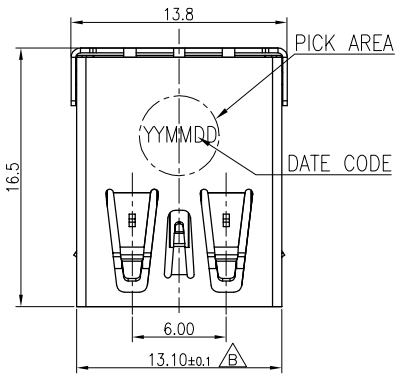
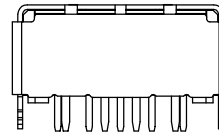
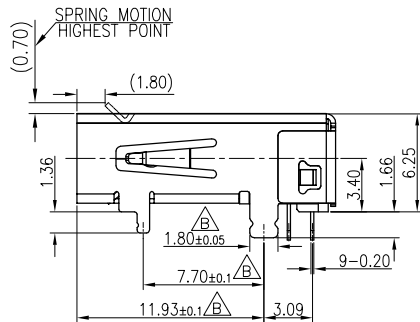
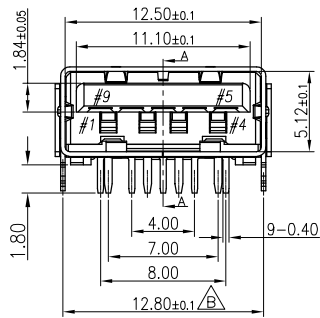
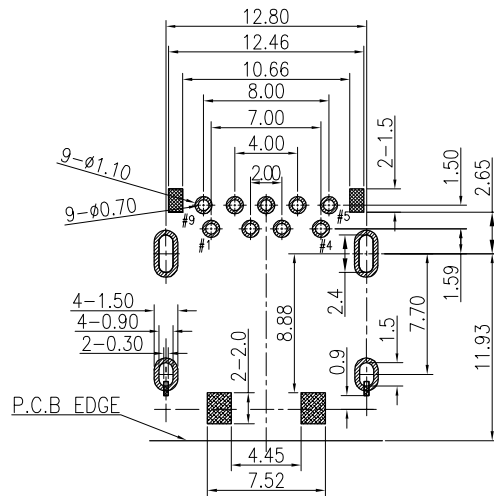

TABLE:

NO	P/N	COLOR	PLATING
1	2UB2Y90-330111F	BLACK	Au 30u" ON CONTACT AREA AND MATTE SN 100u"MIN. ON SOLDER TAIL ALL OVER NICKEL PLATING
2	2UB2Y90-315111F	BLACK	Au 15u" ON CONTACT AREA AND MATTE SN 100u"MIN. ON SOLDER TAIL ALL OVER NICKEL PLATING
3	2UB2Y90-300121F	BLACK	Au 5u"+Pd/Ni 30u" ON CONTACT AREA AND MATTE SN 100u"MIN. ON SOLDER TAIL ALL OVER NICKEL PLATING
4	2UB2Y90-300111F	BLUE(300C)	

E	SHELL	1	STAINLESS STEEL T=0.30	NICKEL PLATING
D	4P TERMINAL	4	COPPER ALLOY T=0.20	SEE TABLE
C	5P TERMINAL	5	COPPER ALLOY T=0.20	SEE TABLE
B	BLOCK	1	HIGH TEMPERATURE PLASTIC	SEE TABLE
A	HOUSING	1	UL94V-0	SEE TABLE
NO	DESCRIPTION	QTY	MATERIAL	PLATING & COLOR

UNLESS OTHERWISE SPECIFIED TOLERANCES		Singatron Enterprise Co., Ltd. 信音企業股份有限公司						
DECIMALS:		TITLE						
X	:±0.5	USB 3.0 CONNECTOR						
X.X	:±0.3	DWN	<table border="1"> <tr> <td>Nanlin-Chen</td> <td>19/04/22</td> <td>PART NO.2UB2Y90-3XX1X1F</td> </tr> </table>	Nanlin-Chen	19/04/22	PART NO.2UB2Y90-3XX1X1F		
Nanlin-Chen	19/04/22	PART NO.2UB2Y90-3XX1X1F						
X.XX	:±0.2	CHKD	<table border="1"> <tr> <td>Dicai-Hu</td> <td>19/04/22</td> <td>SCALE 1:1</td> <td>UNIT: mm</td> <td></td> </tr> </table>	Dicai-Hu	19/04/22	SCALE 1:1	UNIT: mm	
Dicai-Hu	19/04/22	SCALE 1:1	UNIT: mm					
		APVD	<table border="1"> <tr> <td>clint-in</td> <td>19/04/22</td> <td>SIZE: A3</td> <td>SHEET: 10F1</td> <td>REV: B</td> </tr> </table>	clint-in	19/04/22	SIZE: A3	SHEET: 10F1	REV: B
clint-in	19/04/22	SIZE: A3	SHEET: 10F1	REV: B				
CUSTOMER COPY								



STAND OFF RECOMMENDED P.C.B. LAYOUT
 SPRING TIP AREA(HOLE) TOLERANCE (TOP VIEW) ±0.05mm
 PAD