

REV.	ECN NO OR DESCRIPTION	REVISED	DATE
A	PDR NO.:1090522-3A	Steve	2009.07.30

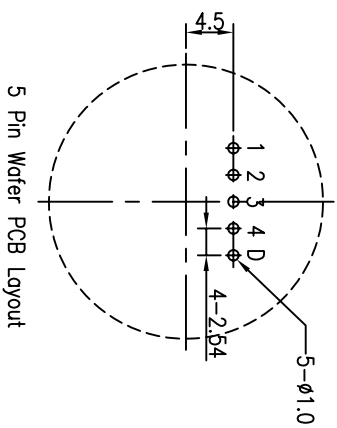

5 Pin Wafer PCB Layout

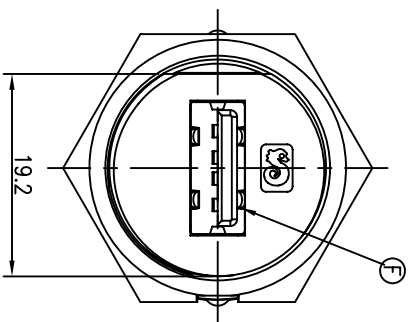
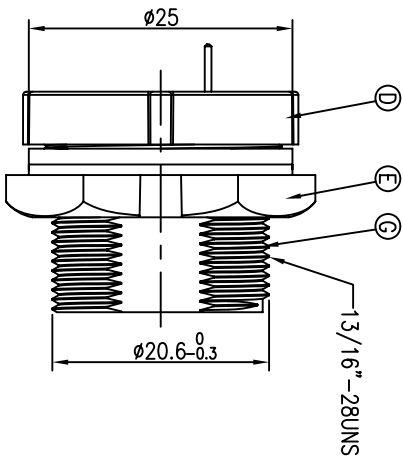
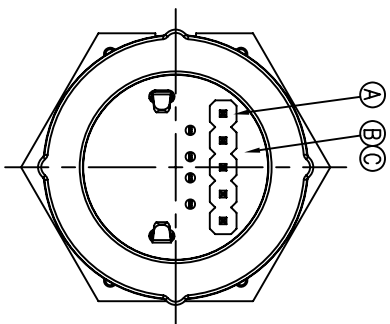

NOTES:

1. WATERPROOF RATE: IP67
IP67: IMMERSED IN 1M WATER FOR 30 MINUTES
2. ELECTRICAL CHARACTERISTICS:
 - 1-1. RATING:30V 1A
 - 1-2. CONTACT RESISTANCE: 30mΩ MAX.(INITIAL)
 - 1-3. DIELECTRIC WITHSTANDING VOLTAGE: 500V AC FOR ONE MINUTE
 - 1-4. INSULATION RESISTANCE: 100MΩ MIN. MEASURED BY 500 VDC
3. OTHER GENERAL SPEC. TO REFER "2UB1518 SERIES SPEC".
4. INSERTION FORCE: 3.5KGF MAX.
WITHDRAW FORCE: 0.5KGF MIN.
5. TO CONFORM TO SINGATRON HAZARDOUS SUBSTANCE FREE SPEC.
6. GREEN PRODUCT IDENTIFICATION LABEL ON PACKAGING: G.P. PASS
7. FOR PANEL THICKNESS MAX OF 4.0mm

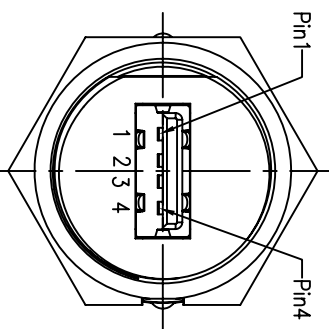

PIN ASSIGNMENTS
FRONT VIEW

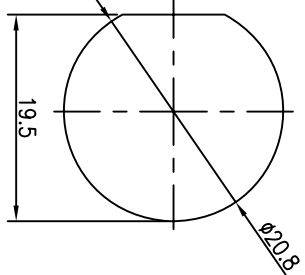

RECOMMENDED PANEL CUT-OUT

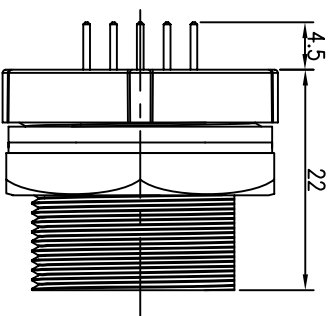
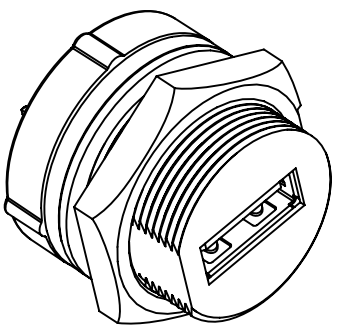

G	HOUSING	1	PPE	BLACK
F	USB A JACK	1	P/N:2UB1518-000111	N/A
E	SCREW NUT	1	PPE	BLACK
D	SEALING NUT	1	PPE	BLACK
C	O-RING	1	EPDM	BLACK
B	PCB	1	FR-4	GREEN
A	WAFER	1	5PIN 2.54PITCH	BLACK
NO	DESCRIPTION	QTY	MATERIAL	PLATING & COLOR
UNLESS OTHERWISE SPECIFIED TOLERANCES				
DECIMALS:	ANGLES:			
X :±0.5	X :±2°			
X.X :±0.3	X.X :±1°			
X.XX :±0.2				
Singatron Enterprise Co., Ltd. 信音企業股份有限公司				
TITLE WATERPROOF USB 2.0 JACK				
DWN	Steve	PART NO.2UB3001-W05100		
CHKD	Quan	SCALE 2:1	UNIT: mm	
APVD	Max	SIZE: A3	SHEET:1 OF 1	REV: A

CUSTOMER COPY