

| REV/ECN NO OR DESCRIPTION | REVISED | DATE |
|---------------------------|---------|------------|
| A PDR NO.:S101230-6A | Shown | 2011.01.08 |

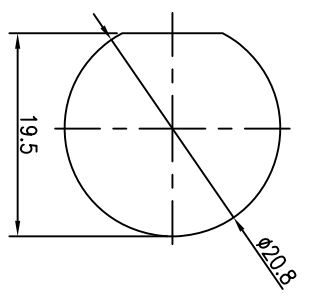

RECOMMENDED PANEL CUT-OUT

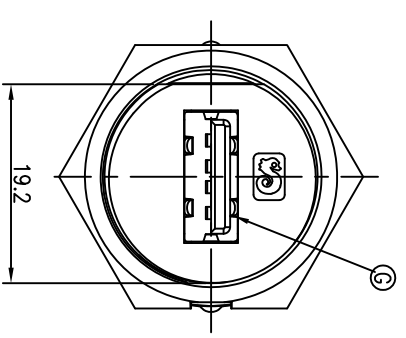
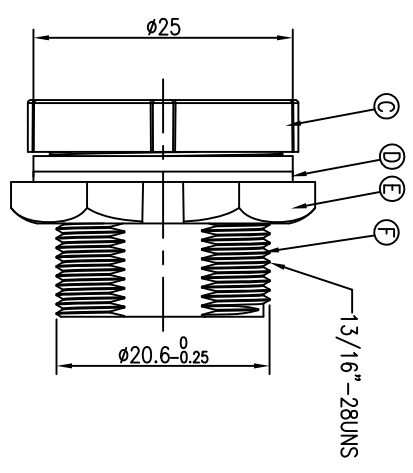
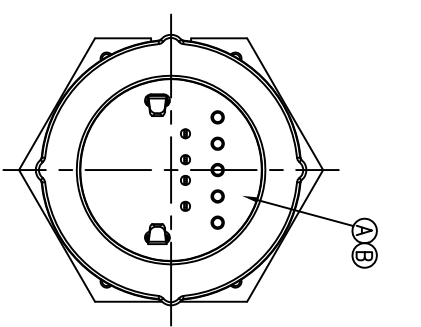
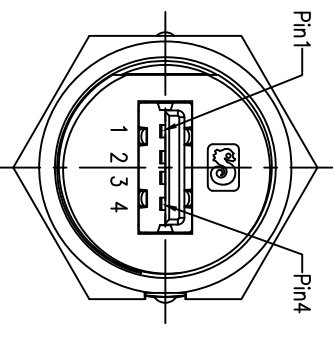

PIN ASSIGNMENTS
FRONT VIEW

- NOTES:
- ELECTRICAL CHARACTERISTICS:
 - RATING:30V 1A
 - CONTACT RESISTANCE: 30mΩ MAX.(INITIAL)
 - DIELECTRIC WITHSTANDING VOLTAGE: 500V AC FOR ONE MINUTE
 - INSULATION RESISTANCE: 100MΩ MIN. MEASURED BY 500 VDC
 - OTHER GENERAL SPEC. TO REFER "2UB1518 SERIES SPEC".
 - INSERTION FORCE: 3.5KGF MAX. WITHDRAW FORCE: 0.5KGF MIN.
 - TO CONFORM TO SINGATRON HAZARDOUS SUBSTANCE FREE SPEC.
 - GREEN PRODUCT IDENTIFICATION LABEL ON PACKAGING:
 - FOR PANEL THICKNESS MAX OF 4.0mm

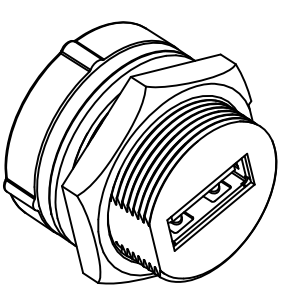
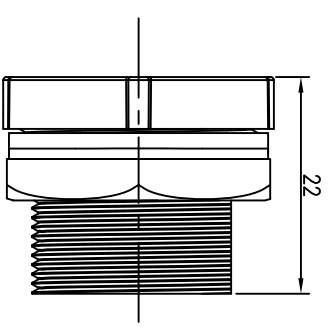

| | | | | |
|---------------------------------------|-------------|-----|--------------------|-----------------|
| G | USB A JACK | 1 | P/N:2UB1518-000111 | N/A |
| F | HOUSING | 1 | PPE | BLACK |
| E | SCREW NUT | 1 | PPE | BLACK |
| D | GASKET | 1 | EPDM | BLACK |
| C | SEALING NUT | 1 | PPE | BLACK |
| B | O-RING | 1 | EPDM | BLACK |
| A | PGB | 1 | FR-4 | GREEN |
| NO | DESCRIPTION | QTY | MATERIAL | PLATING & COLOR |
| UNLESS OTHERWISE SPECIFIED TOLERANCES | | | | |
| Singaton Enterprise Co., Ltd. | | | | |
| TITLE WATERPROOF USB 2.0 JACK | | | | |
| DECIMALS: | ANGLES: | | | |
| X :±0.5 | X :±2° | | | |
| XX :±0.3 | XX :±1° | | | |
| XXX :±0.2 | | | | |
| DWG Shown PART NO.2UB3001-W05111 | | | | |
| CHKD Steve SCALE 2:1 UNIT: mm | | | | |
| APVD Max SIZE: A3 SHEET:1 OF 1 REV: A | | | | |
| CUSTOMER COPY | | | | |