

REV.	ECN NO OR DESCRIPTION	REVISED	DATE
A	PDR NO.:S120104-5A	Shown	2012.01.13

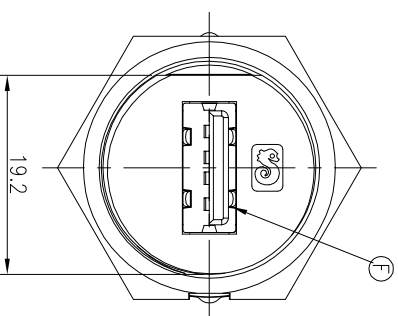

- NOTES:
1. WATERPROOF RATE: IP67
IP67: IMMersed IN 1M WATER FOR 30 MINUTES
 2. ELECTRICAL CHARACTERISTICS:
 - 1-1. RATING:30V 1A
 - 1-2. CONTACT RESISTANCE: 30mohm MAX.(INITIAL)
 - 1-3. DIELECTRIC WITHSTANDING VOLTAGE: 500V AC FOR ONE MINUTE
 - 1-4. INSULATION RESISTANCE: 100Mohm MIN. MEASURED BY 500 VDC
 3. OTHER GENERAL SPEC. TO REFER "ZUB1518 SERIES SPEC".
 4. INSERTION FORCE: 3.5KGF MAX.
WITHDRAW FORCE: 0.5KGF MIN.
 5. TO CONFORM TO SINGATRON HAZARDOUS SUBSTANCE FREE SPEC.
 6. GREEN PRODUCT IDENTIFICATION LABEL ON PACKAGING: **GR PASS**
 7. FOR PANEL THICKNESS MAX OF 4.0mm

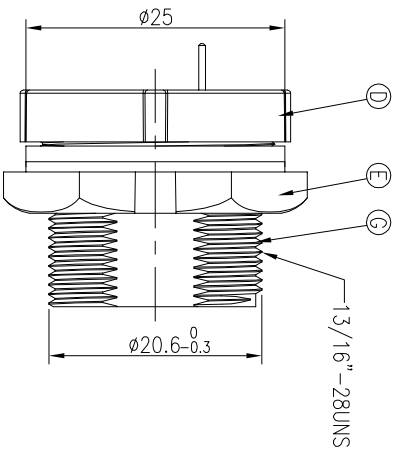
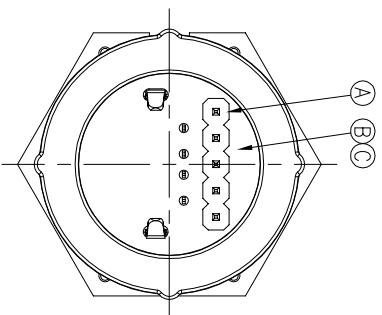
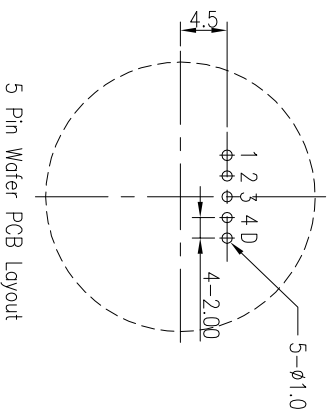
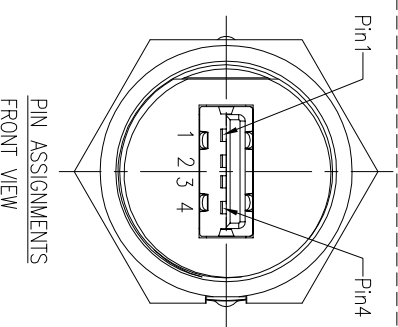
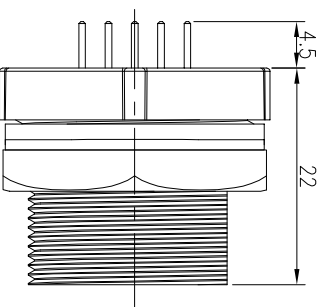

PIN ASSIGNMENTS
FRONT VIEW

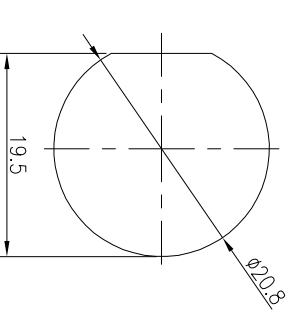

RECOMMENDED PANEL CUT-OUT

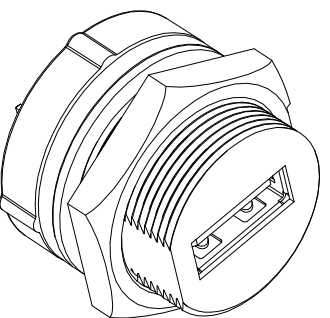

G	HOUSING	1	PPE	BLACK
F	USB A JACK	1	P/N:ZUB1518-000111	N/A
E	SCREW NUT	1	PPE	BLACK
D	SEALING NUT	1	PPE	BLACK
C	O-RING	1	EPDM	BLACK
B	PCB	1	FR-4	GREEN
A	WAFER	1	5PIN 2.0 PITCH	BLACK
NO	DESCRIPTION	QTY	MATERIAL	PLATING & COLOR

UNLESS OTHERWISE SPECIFIED TOLERANCES

DECIMALS: ANGLES:

X :±0.5 X :±2°
X.X :±0.3 X.X :±1°
X.XX :±0.2

Singatron Enterprise Co., Ltd.
信音企業股份有限公司

WATERPROOF USB 2.0 JACK

TITLE PART NO.ZUB3001-W05119H

DWN Shown
CHKD Harlen
APVD Tony

SCALE 2:1 UNIT: mm
SIZE: A3 SHEET:1 OF 1 REV: A
CUSTOMER COPY