

REV.	ECN NO. OR DESCRIPTION	REVISED	DATE
A	PDR NO.:S120224-9A	Shown	2012.04.11

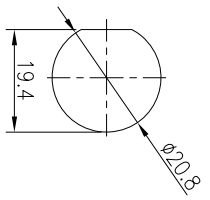
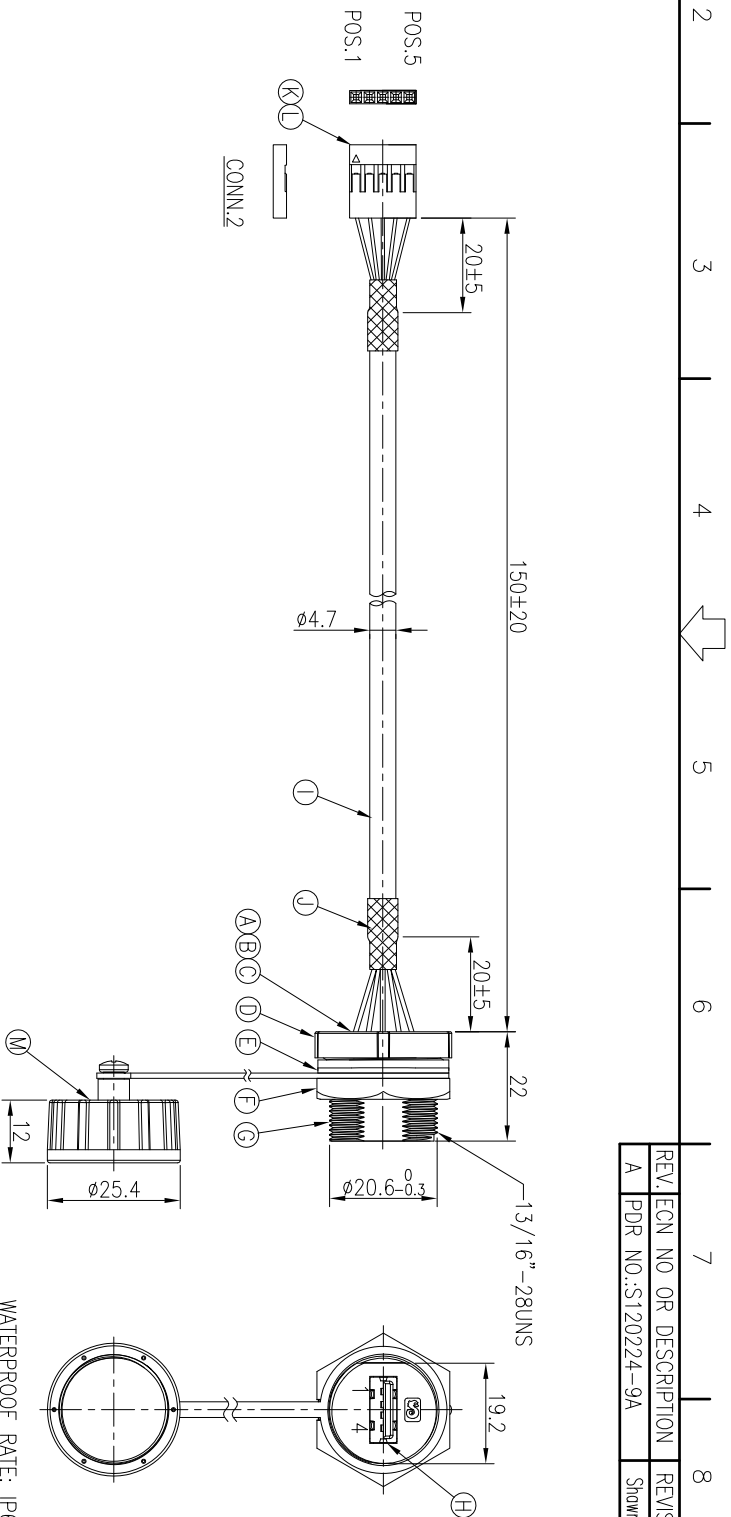

	DRAIN	SHIELD
5	BLACK(24AWG)	4
4	GREEN(28AWG)	3
3	WHITE (28AWG)	2
2	RED (24AWG)	1
1	WIRE COLOR	CONN.1

Twist

CONN.1

PIN 4

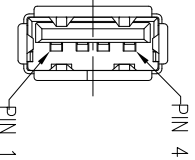

Pin Assignments  
Front View

- NOTES:
1. WATERPROOF RATE: IP67
  2. RATING: 30V 1A
  3. SPECIFICATIONS:SEE "USB SERIES SPECIFICATIONS".
  4. TO CONFORM TO SINGATRON HAZARDOUS SUBSTANCE FREE SPEC.
  5. GREEN PRODUCT IDENTIFICATION LABEL ON PACKAGING: **G.P. PASS**
  6. FOR PANEL THICKNESS MAX:2.5mm

WATERPROOF RATE: IP67  
Conn.1

M	WATERPROOF CAP	1	P/N:2UB3001-W0000W	N/A
L	TERMINAL	5	A2541T3P-2	TIN PLATED
K	HOUSING	1	A2541H02-05P	BLACK
J	SHRINK TUBE	2	φ5*15	BLACK
I	CABLE	1	USB2.0 28#*1P+24# *2C+ADB,UV RESISTANT	BLACK PVC JACKET
H	USB A JACK	1	P/N:2UB1518-000111	N/A
G	HOUSING	1	PPE 540Z	BLACK
F	SCREW NUT	1	PPE 540Z	BLACK
E	GASKET	1	EPDM	BLACK
D	SEALING NUT	1	PPE 540Z	BLACK
C	THERMAL GLUE	1	N/A	NATURAL
B	O-RING	1	EPDM	BLACK
A	PCB	1	FR-4	GREEN
NO	DESCRIPTION	QTY	MATERIAL	PLATING & COLOR

UNLESS OTHERWISE SPECIFIED TOLERANCES

DECIMALS:	ANGLES:
X :±0.5	X :±2°
X.X :±0.3	X.X :±1°
X.XX :±0.2	

TITLE	WATERPROOF USB2.0 JACK
DWN	Shown
CHKD	Horlen
APVD	Tony
PART NO.	2UB3001-W05121H
SCALE	1:1
UNIT:	mm
SIZE:	A3
SHEET:	1 OF 1
REV:	A

Singatron Enterprise Co., Ltd.  
信音企業股份有限公司  
CUSTOMER COPY

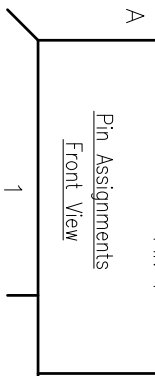

2

3

4

5

6

7

8