

REV.	ECN NO OR DESCRIPTION	REVISED	DATE
A	PDR NO:T120528-3A	Harlen	2012.7.16
B	ECN NO.:S121018	LILY	2012.12.17

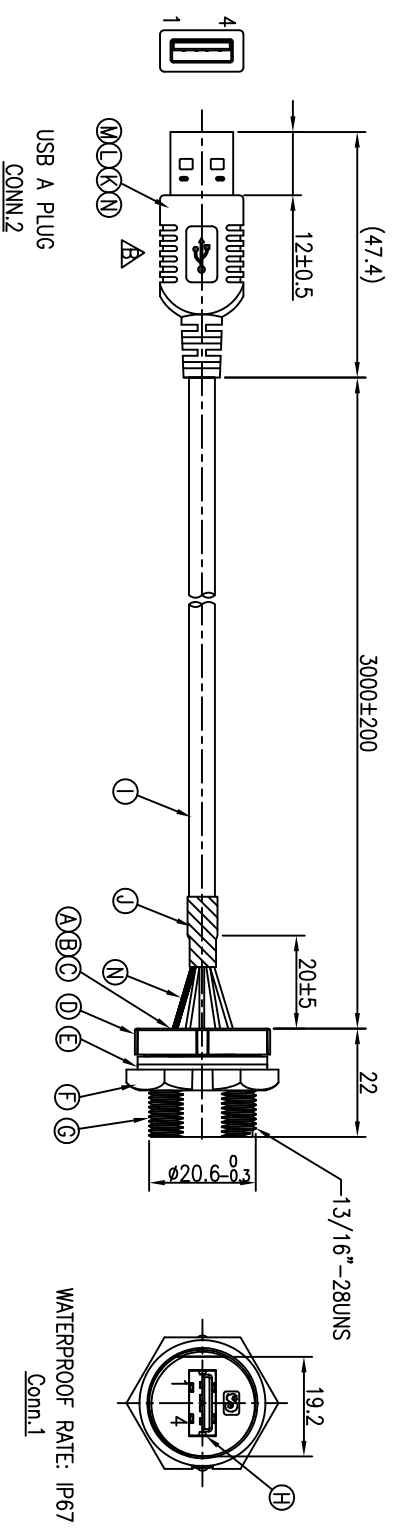
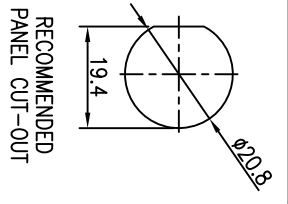

WATERPROOF RATE: IP67
Conn.1

SHIELD	DRAIN	SHIELD
4	BLACK(24AWG)	4
3	GREEN(28AWG)	3
2	WHITE (28AWG)	2
1	RED (24AWG)	1
CONN.2 WIRE COLOR		CONN.1
PIN OUT		

Twist

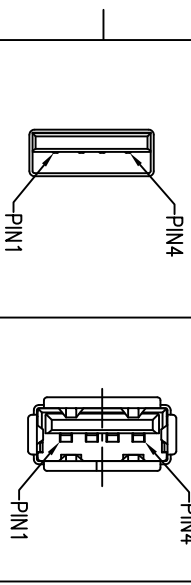
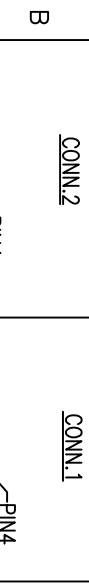

NOTES:

1. WATERPROOF RATE: IP67
2. RATING: 30V 1A
3. SPECIFICATIONS:SEE "USB SERIES SPECIFICATIONS".
4. TO CONFORM TO SINGATRON HAZARDOUS SUBSTANCE FREE SPEC.
5. GREEN PRODUCT IDENTIFICATION LABEL ON PACKAGING:
6. FOR PANEL THICKNESS MAX.:3.5mm

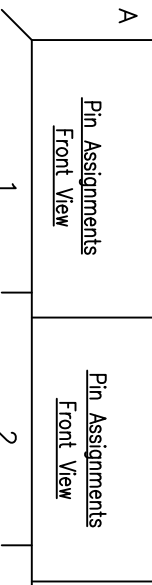

NO	DESCRIPTION	QTY	MATERIAL	PLATING & COLOR
N	INNER MOLD	1	LD-PE	N/A
M	HEAT SHRINK TUBE	2	DD1.0 125°C 300V	BLACK
L	USB PLUG	1	USB2.0 PLUG	N/A
K	OVER MOLD	1	PVC	BLACK
J	SHRINK TUBE	1	φ5*20	BLACK
I	CABLE	1	USB2.0 28#*1P+24#*2C+ADB,UV Resistant	BLACK (PVC JACKET)
H	USB A JACK	1	P/N:2UB1518-000111	N/A
G	HOUSING	1	PPE	BLACK
F	SCREW NUT	1	PPE	BLACK
E	GASKET	1	EPDM	BLACK
D	SEALING NUT	1	PPE	BLACK
C	THERMAL GLUE	1	φ7.0	NATURAL
B	O-RING	1	EPDM	BLACK
A	PGB	1	FR-4	GREEN

UNLESS OTHERWISE SPECIFIED TOLERANCES
 Singatron Enterprise Co., Ltd.
 信音企業股份有限公司

DECIMALS:	ANGLES:	TITLE	WATERPROOF	JACK TO USB PLUG
X :±0.5	X :±2°	DMW	LILY	PART NO.2UB3001-W05125H
XX :±0.3	XX :±1°	CHKD	Harlen	SCALE 1:1 UNIT: mm
XXX :±0.2		APVD	Steve	SIZE: A3 SHEET:1 OF 1 REV: B

CUSTOMER COPY