

REV.	ECN NO OR DESCRIPTION	REVISION	DATE
A	PDR NO:T141020-5A	YF	2015.01.22

2015/01/23  
10:11:06

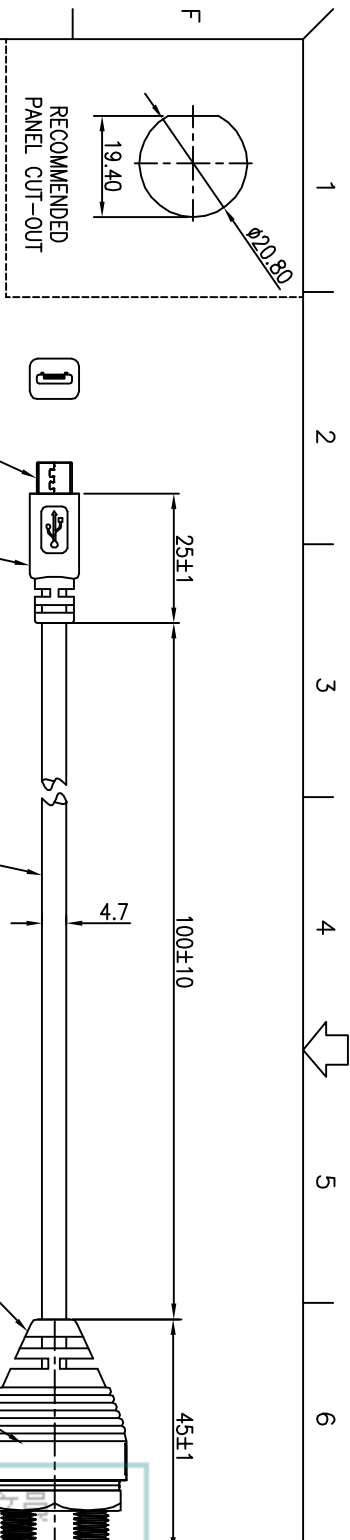

WATERPROOF RATE: IP67  
Conn.1

SHIELD	DRAIN	SHIELD
4+5	BLACK(24AWG)	4
3	GREEN(28AWG)	3
2	WHITE(28AWG)	2
1	RED(24AWG)	1
CONN.2	WIRE COLOR	CONN.1
	PIN OUT	

Twist

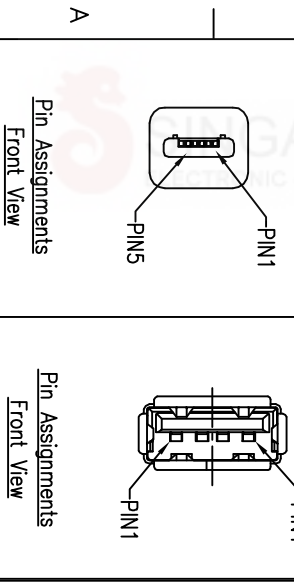
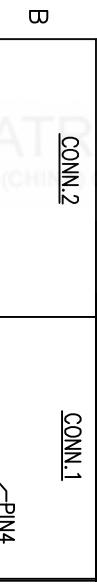

NOTES:

1. WATERPROOF RATE: IP67
2. RATING: 30V 1A
3. SPECIFICATIONS: SEE "USB SERIES SPECIFICATIONS".
4. TO CONFORM TO SINGATRON HAZARDOUS SUBSTANCE FREE SPEC.
5. GREEN PRODUCT IDENTIFICATION LABEL ON PACKAGING:
6. FOR PANEL THICKNESS MAX: 2.5mm
7. 螺母、螺圈及防護蓋以附件形式包裝出貨

O	OVER MOLD	1	TPU	BLACK
N	HEAT SHRINK TUBE	2	Ø1.0 125°C 300V L:10	BLACK
M	INNER MOLD	1	LD-PE	WHITE
L	WATERPROOF CAP	1	P/N:2UB3001-W0000W	N/A
K	USB PLUG	1	MICRO USB A SP PLUG	BLACK PLASTIC
I	OVER MOLD	1	PVC	BLACK
H	CABLE	1	UL2725 28AWG*1P+24 AWG*2C+AL+D+R(VV)	BLACK(PVC JACKET)
G	USB A JACK	1	P/N:2UB1518-000111	WHITE PLASTIC
F	HOUSING	1	PPE	BLACK
E	SCREW NUT	1	PPE	BLACK
D	GASKET	1	EPDM	BLACK
C	SEALING NUT	1	PPE	BLACK
B	O-RING	1	EPDM	BLACK
A	PCB	1	FR-4	GREEN
NO	DESCRIPTION	QTY	MATERIAL	PLATING & COLOR

UNLESS OTHERWISE SPECIFIED TOLERANCES

DECIMALS:	ANGLES:	TITLE	WATERPROOF	USB2.0 JACK TO MICRO USB PLUG
X :±0.5	X :±2°	DMN	YF	PART NO. 2UB3001-W05162H
XX :±0.3	XX :±1°	CHKD	Harlen	SCALE 1:1 UNIT: mm
XXX :±0.2		APVD	Steve	SIZE: A3 SHEET: 1 OF 1 REV: A

Singatron Enterprise Co., Ltd.  
信譽企業股份有限公司

**CUSTOMER COPY**