

REV.	ECN NO.	OR DESCRIPTION	REVISED	DATE
A	PDR NO.1150623-4A	Yong	2015.11.26	

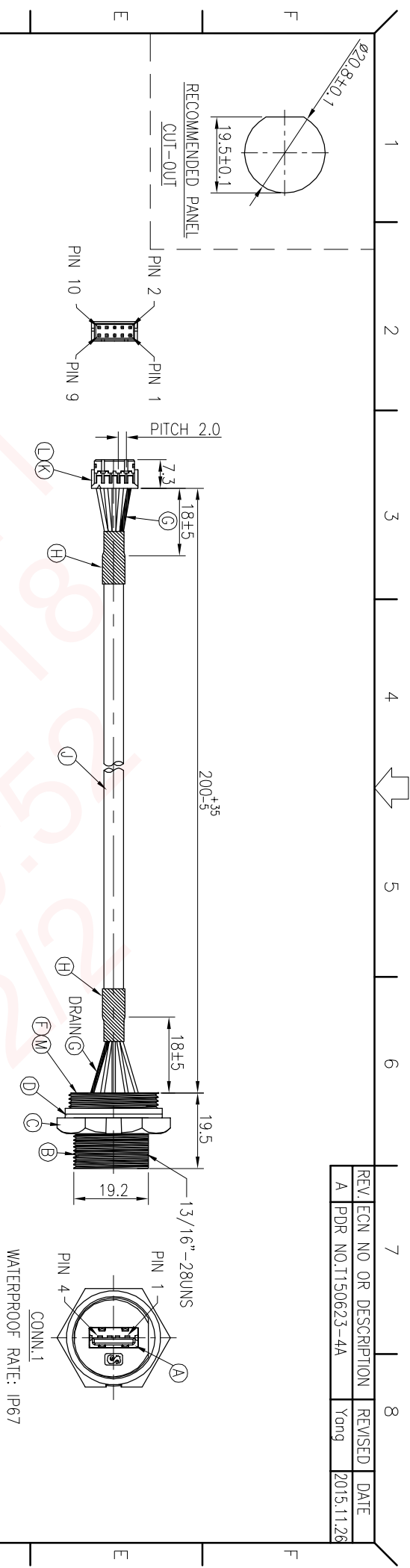

9	DRAIN	SHIELD	4
7	BLACK(24AWG)		
5	GREEN(28AWG)		
3	WHITE(28AWG)		
1	RED(24AWG)		
CONN.2		WIRE COLOR	CONN.1
PIN OUT			
CONN.2			
PIN 2			
PIN 1			
CONN.1			
PIN 4			

1	FRONT VIEW		
2	FRONT VIEW		
NOTES:			
1. WATERPROOF RATE: IP67			
IP67: IMMERSED IN 1M WATER FOR 30 MINUTES			
2. RATING: 30V 1A			
3. OPERATING TEMPERATURE: -40°C TO+95°C (PANEL).			
4. SPECIFICATIONS:SEE "USB SERIES SPECIFICATIONS".			
5. TO CONFORM TO SINGATRON HAZARDOUS SUBSTANCE FREE SPEC.			
6. GREEN PRODUCT IDENTIFICATION LABEL ON PACKAGING: G.P. PASS			
7. FOR PANEL THICKNESS MAX:4.0mm			
8. DEFINE PIN ASSIGNMENT BY CUSTOMER REQUIREMENT			
M	UV GLUE	1	N/A
L	TERMINAL	5	PHOSPHOR BRONZE
K	HOUSING	1	NYLON 66 UL 94V-0
J	CABLE	1	USB2.0 28#*1P+24#*2C+ADB,UV Resistant
H	HEAT SHRINK TUBE	2	125°C 300V
G	HEAT SHRINK TUBE	2	125°C 300V
F	LIQUID GLUE	1	N/A
E	PCB	1	FR-4
D	GASKET	1	EPDM
C	PANEL NUT	1	NYLON+GF
B	BODY	1	PPE
A	USB CONNECTOR	1	USB A JACK
NO	DESCRIPTION	QTY	MATERIAL
UNLESS OTHERWISE SPECIFIED TOLERANCES			
DECIMALS: ANGLES:			
X	:±0.5	X	:±2°
X.X	:±0.3	X.X	:±1°
X.XX	:±0.2		
TITLE WATERPROOF USB JACK TO CONNECTOR			
DWN	Yong	PART NO.201503001-W05173H	
CHKD	JF	SCALE 1:1	UNIT: mm
APVD	Horlen	SIZE: A3	SHEET: 1 OF 1
CUSTOMER COPY			