

REV.	ECN NO.	OR DESCRIPTION	REVISED	DATE
A	PDR NO.:S140519-8A		Vicky	2014.05.13
B	ECN NO.:S150412-C		Blues	2015.04.10
C	ECN NO.:S160629-C		Vicky	2016.06.20

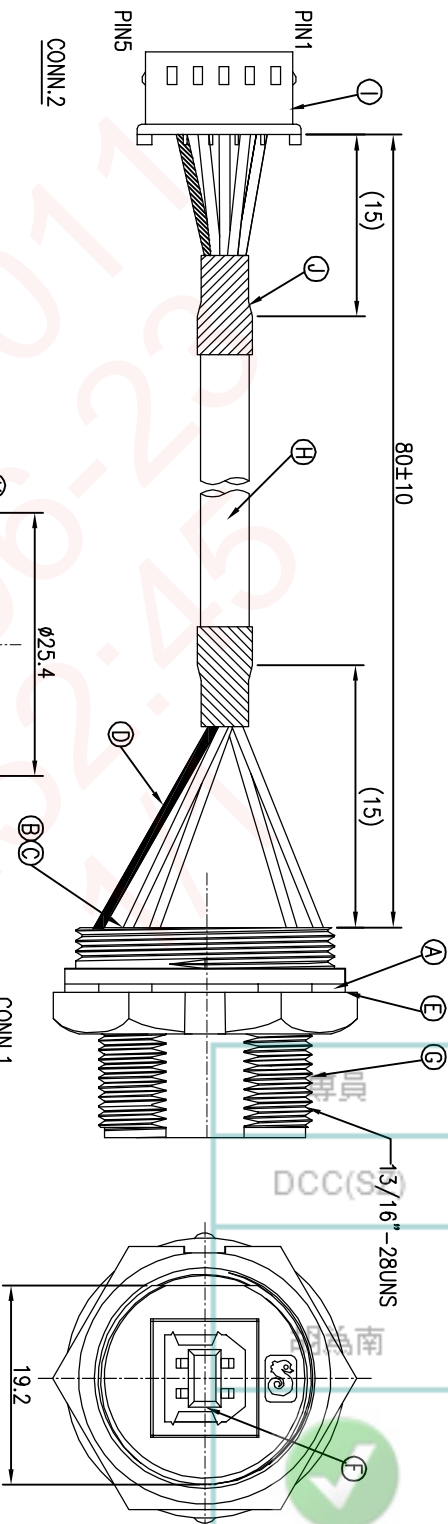

CONN.2	WIRE COLOR	CONN.1
1	RED	1
2	WHITE	2
3	GREEN	3
4	BLACK	4
5	DRAIN	SHIELD

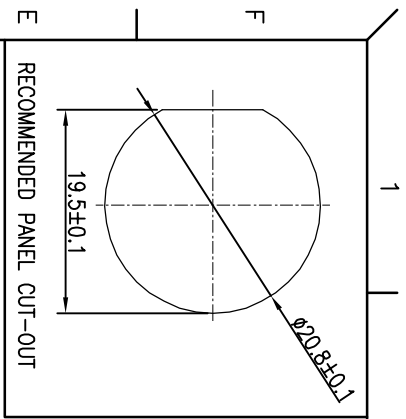
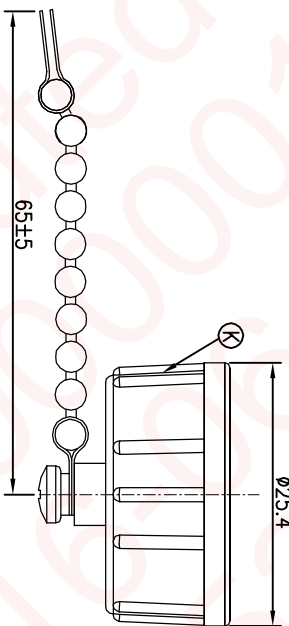

- NOTES:
- ELECTRICAL CHARACTERISTICS:
 - 1-1 CURRENT RATING: 1.0 AMPS.
 - 1-2 CONTACT RESISTANCE: 3 Ohm Max.
 - 1-3 INSULATION RESISTANCE: 30 Mohm Min. at 300VDC.
 - 1-4 BREAKDOWN VOLTAGE: 300 VAC PER MINUTE.
 - ENVIRONMENTAL:
 - 2-1 OPERATING TEMPERATURE: -40°C TO +80°C.
 - 2-2 SEALING REQUIREMENTS: IP67.
 - OTHER GENERAL SPEC. TO REFER "USB WPC SPEC."
 - FOR TECHNICAL DATA REFER TO YOUR LOCAL SINGATRON ELECTRONICS SALES OFFICE.
 - ALL DIMENSIONS ARE NOMINAL FOR REFERENCE ONLY UNLESS OTHERWISE STATED.
 - TO CONFORM TO SINGATRON HAZARDOUS SUBSTANCE FREE SPEC.
 - WATERPROOF CAP 以附件形式包裝出貨.
 - GREEN PRODUCT IDENTIFICATION LABEL ON PACKAGING:

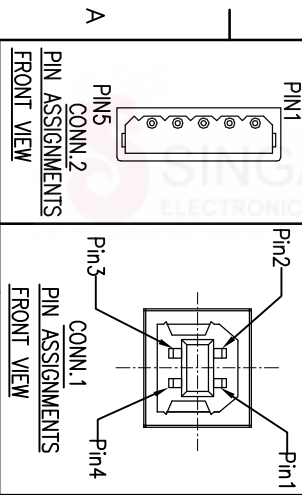

K	WATERPROOF CAP	1	2UB3001-W0005W	N/A
J	HEAT SHRINK TUBE	2	POLYUFIEN Ø5.0	BLACK
I	CONNECTOR	5	BRASS	TIN PLATING
		1	NYLON 66	MILKY YELLOW
H	CABLE	1	USB2.0 28#*1P+24#*2C+ADB,UV	BLACK
G	HOUSING	1	PPE	BLACK
F	USB B RECEPTACLE	1	USB B TYPE	N/A
E	SCREW NUT	1	PA66	BLACK
D	HEAT SHRINK TUBE	2	POLYUFIEN Ø1.0	BLACK
C	LIQUID GLUE	1	N/A	BLACK
B	PCB	1	FR-4	GREEN
A	GASKET	1	EPDM SHORE	BLACK
NO	DESCRIPTION	QTY	MATERIAL	PLATING & COLOR

UNLESS OTHERWISE SPECIFIED TOLERANCES

DECIMALS:	ANGLES:
X :±0.5	X :±2°
X.X :±0.3	X.X :±1°
X.XX :±0.2	

Singatron Enterprise Co., Ltd.
信亨企業股份有限公司

TITLE: WATERPROOF USB 2.0 RECEPTACLE

DWN Vicky PART NO. 2UB3003-W05108H

CHKD Harlen SCALE 2:1 UNIT: mm

APVD Steve SIZE: A3 SHEET: 1 OF 1 REV: C

CUSTOMER COPY