





SPECIFICATION

1. CONTACT CURRENT RATING 1.0A AT 250V AC
2. CONTACT RESISTANCE 40mOHMS
3. INSULATION RESISTANCE 100MOHMS
4. DIELECTRIC WITHSTANDING VOLTAGE 100V AC FOR 1 MINUTE
5. INSERTION FORCE 3.5Kgf Max
6. EXTRACTION FORCE 1.0Kgf MIN(INITIAL)
0.8Kgf MIN(12000 CYCLES)
7. DURABILITY 12000 INSERTION/EXTRACTION CYCLES
8. OPERATING TEMPERATURE -55°~85°
9. I.R FOLLOW CHART PEAK TEMPERATURE 250°±5 10SEC.
10. PACKAGE TAPE REEL
11. TO CONFORM TO SINGATRON HAZARDOUS SUBSTANCE FREE SPEC.
12. GREEN PRODUCT IDENTIFICATION MARK IN JACK:  **GP-PASS**
13. GREEN PRODUCT IDENTIFICATION LABEL IN PACKING:  **GP-PASS**
14. FOR WAVE SOLDERING LEAD-FREE PROCESS.
15. PRINTED DATE CODE **YYMMDD** ON TOP OF CONNECTOR.

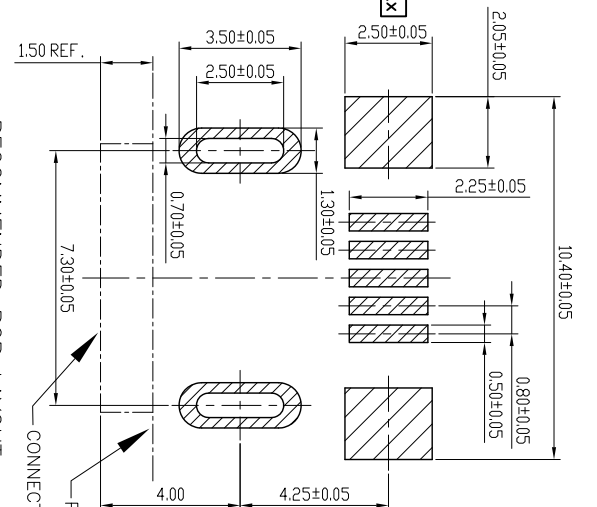
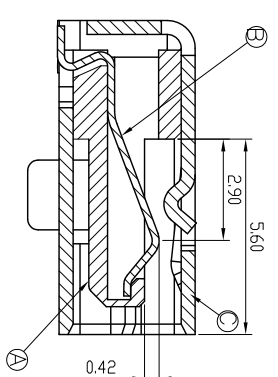
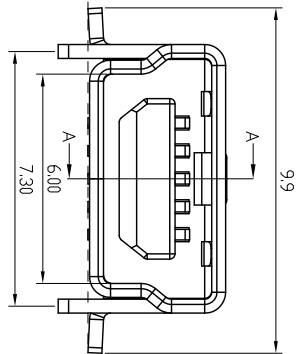
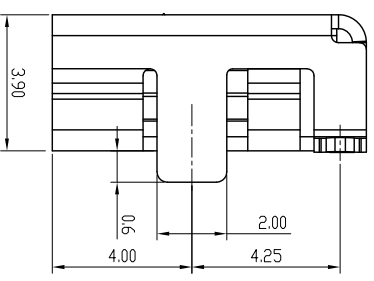
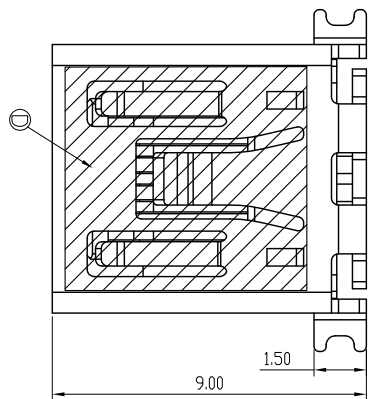

REV.	ECN NO. OR DESCRIPTION	REVISED	DATE
A	PDR RELEASE	LSS91	2002.8.30
B	ECN NO.:S120750	SEM	2012.02.31

D	MYLAR	1	KAPTON	YELLOW
C	SHELL	1	SUS304 0.4T	PLATED 60u" Ni(可焊接)
B	TERMINAL	5	PHOSPHOR BRONZE 0.2T	CONTACT 3u" Au ALL PLATED GOLD FLASH
A	BODY	1	NY9T 30% GF UL 94V-0	BLACK
NO	DESCRIPTION	QTY	MATERIAL	PLATING & COLOR
UNLESS OTHERWISE SPECIFIED TOLERANCES				
 Singaton Enterprise Co., Ltd. 信音企業股份有限公司				
DECIMALS:		ANGLES:		
X	:±0.50	X	:±2°	
X,X	:±0.30	X,X	:±1°	
X,XX	:±0.20			
TITLE		MINI USB B /DIP+SMT TYPE		
DWN	SEAN	PART NO. 2UB3031-000121		
CHKD	TOM	SCALE:1:1	UNIT: mm	
APVD	QUAN	SIZE: A3	SHEET: 1 OF 1	REV: B

CUSTOMER COPY