

REV.	ECN NO.	OR DESCRIPTION	REVISED	DATE
A	PDR NO.:	T191220-2A	JAY	2023.04.25

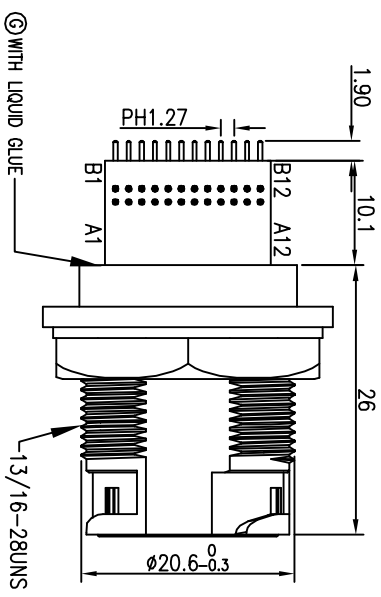

- NOTES:
1. WATERPROOF RATE: IP67  
IP67: IMMERSED IN 1M WATER FOR 30 MINUTES.
  2. RATING: 20V 5A
  3. TO CONFORM TO SINGATRON HAZARDOUS SUBSTANCE FREE SPEC.
  4. GREEN PRODUCT IDENTIFICATION LABEL ON PACKAGING: **G.P. PASS**
  5. Torque Force: 1.0 ~ 1.2 Nm
  6. Recommend Panel Thickness : 0.8 ~ 1.9mm
  7. LASE DATE CODE "YYMMDD" ON TOP OF CONN.  
DATE CODE: YYMMDD

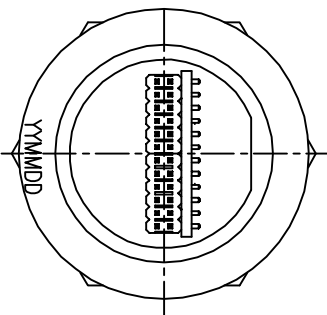
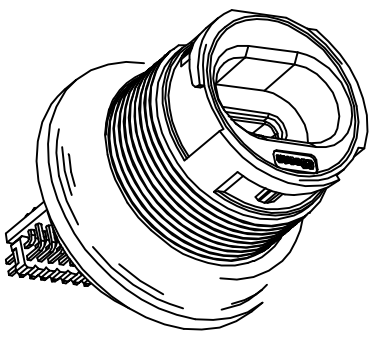
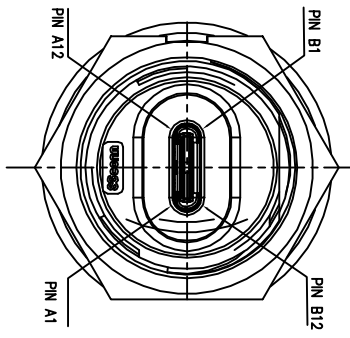
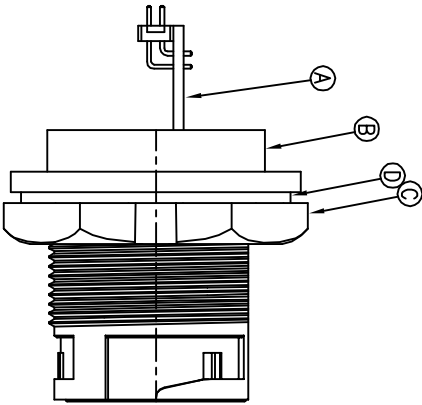
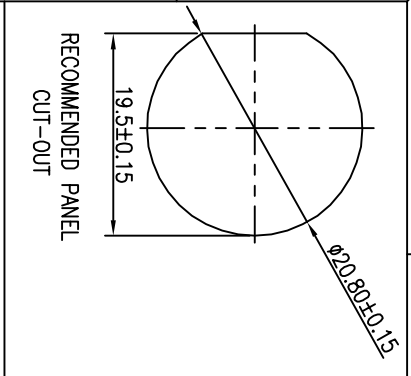
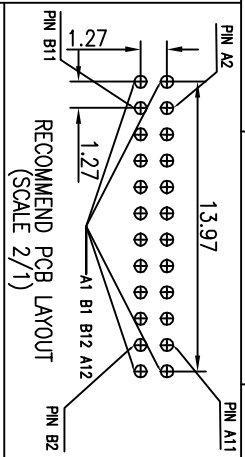
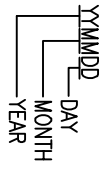

E	LIQUID GLUE	1	N/A	BLACK
D	GASKET	1	SILICONE	DARK GRAY
C	NUT	1	NYLON+GF	BLACK
B	HOUSING	1	NYLON+GF	BLACK
A	PCBA	1	TYPE-C USB3.1 PCH1.27MM	N/A
NO	DESCRIPTION	QTY	MATERIAL	PLATING & COLOR
UNLESS OTHERWISE SPECIFIED TOLERANCES				
Suzhou Singatron Auto Electronics CO.,LTD. 蘇州信晉汽車電子有限公司				
TITLE		WATERPROOF TYPE-C USB2.0 JACK		
DWN	JAY	PART NO.:	20VB3040-W24300H	
CHKD	JF	SCALE	2:1	UNIT: mm
APVD	Steve	SIZE:	A3	SHEET: 1 OF 1
REV: A				

CUSTOMER COPY