

REV.	ECN NO OR DESCRIPTION	REVISED	DATE
A	PDR RELEASE	EVEN	2024.01.31

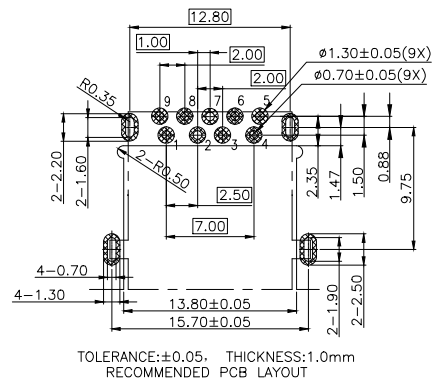

- SPECIFICATIONS:**
- ELECTRICAL CHARACTERISTICS:**
    - CURRENT RATING: 1.8A (PIN1,4) ; OTHER CONTACTS 0.25A
    - CONTACT RESISTANCE: 30mΩ MAX.
    - INSULATION RESISTANCE: 100MΩ MIN. @100V DC.
    - DIELECTRIC WITHSTANDING VOLTAGE: 300V AC FOR 1 MINUTE.
  - MECHANICAL CHARACTERISTICS:**
    - INSERTION FORCE: 1.02~2.25 Kgf FOR INITIAL, AND 0.816~2.25Kgf AFTER TEST.
    - WITHDRAWAL FORCE: 1.02~2.25 Kgf FOR INITIAL, AND 0.816~2.25Kgf AFTER TEST.
  - LIFE TEST: 5,000 CYCLES.
  - TO CONFORM TO THE SINGATRON HAZARDOUS SUBSTANCE FREE SPEC.
  - HALOGEN FREE PRODUCT IDENTIFICATION LABEL ON PACKAGING.
  - PACKAGE: SEE "2UB3912-020415F" PACKAGE.
  - FOR REFLOW SOLDERING LEAD-FREE PROCESS.
  - OTHER GENERAL SPEC. TO REFER "2UB3912-020415F SPEC".

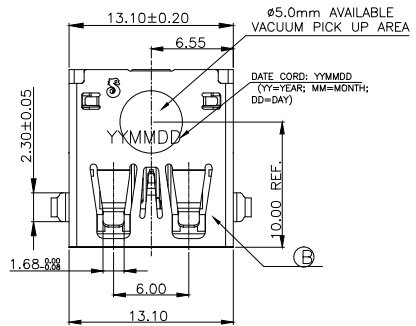
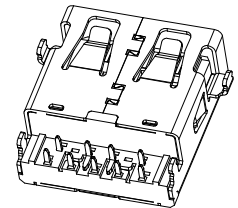
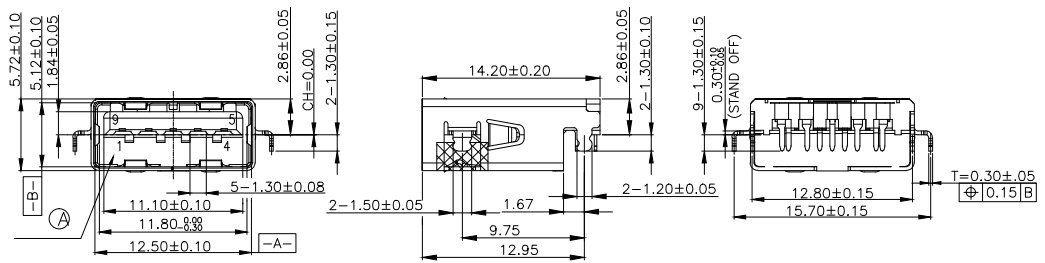

**PART NO.**  
**2UB3912-020415F**

TERMINAL & SHELL LEG LENGTH:  
2: 1.30mm

- SUFFIX: HALOGEN FREE
- PACKAGE: 5: TAPE & REEL
- HOUSING & BASE COLOR: 1: BLACK
- CONTACT PLATING: 4: 10u" GOLD ON CONTACT AREA, MATTE Sn 60u" MIN. ON SOLDERING AREA, 50u" MIN. NICKEL UNDER PLATING OVERALL

P/N	SIGNAL ASSIGNMENT
1#	VBUS
2#	D-
3#	D+
4#	PGND
5#	SSRX-
6#	SSRX+
7#	GND
8#	SSTX-
9#	SSTX+

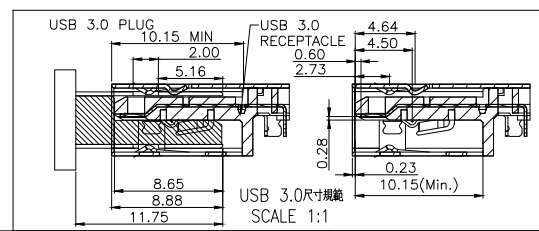
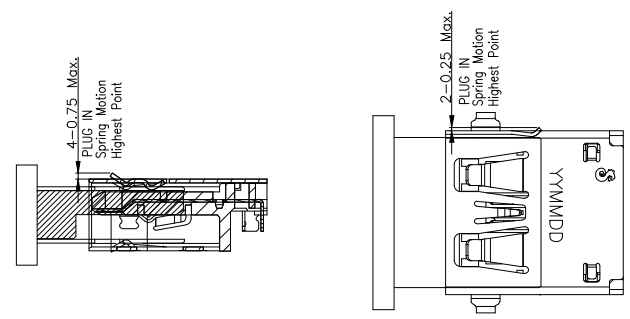
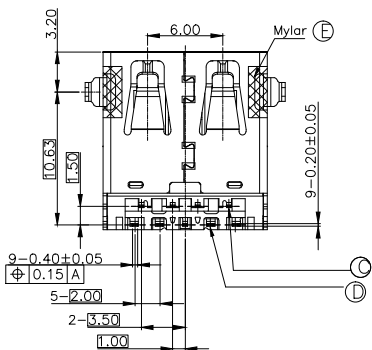

E	MYLAR	2	KAPTON FILM	YELLOW
D	5PIN TERMINAL	5	C2680-H, 0.20t	SEE PART NO.
C	4PIN TERMINAL	4	C5210-EH, 0.20t	SEE PART NO.
B	SHELL	1	SUS304-3/4H T=0.30	NICKEL 50u" MIN
A	HOUSING	1	PA9T, UL94-V0	SEE PART NO.
NO	DESCRIPTION	QTY	MATERIAL	PLATING & COLOR

UNLESS OTHERWISE SPECIFIED TOLERANCES

Singatron Enterprise Co., Ltd.  
信音企業股份有限公司

TITLE: USB 3.0 REVERSE CONNECTOR

DECIMALS: X :±0.5 X.X :±0.3 X.XX :±0.2

ANGLES: X :±2° X.X :±1°

DWN: 2024.01.31  
CHKD:  
APVD: 2024.01.31

SCALE: N/A UNIT: mm

SIZE: A3 SHEET: 1 OF 1 REV: A

**CUSTOMER COPY**