

1 2 3 4 5 6 7 8

REV.	ECN NO OR DESCRIPTION	REVISED	DATE
B	ECN NO: L170044	Even	2017.05.19
C	ECN NO: L202001-C03/L202003-C03	IVY-C	2020.04.20

SPECIFICATIONS:

- ELECTRICAL CHARACTERISTICS:
  - CURRENT RATING: 1.8A (PIN1,4), THE OTHER CONTACTS 0.25A MIN.
  - CONTACT RESISTANCE: 30mΩ MAX.
  - INSULATION RESISTANCE: 100MΩ MIN.
  - DIELECTRIC WITHSTANDING VOLTAGE: 100V AC FOR 1 MINUTE.
- MECHANICAL CHARACTERISTICS:
  - INSERTION FORCE: 35N MAX.
  - WITHDRAWAL FORCE: 10N MIN. FOR INITIAL, AND 8N MIN. AFTER TEST.
- LIFE TEST: 5,000 CYCLES.
- TEMPERATURE RANGE: -55°C TO +85°C.
- TO CONFORM TO THE SINGATRON HAZARDOUS SUBSTANCE FREE SPEC.
- HALOGEN FREE PRODUCT IDENTIFICATION LABEL ON PACKAGING: 
- 2UB3921-000101F PACKAGE: SEE "2UB3921 SERIES" PACKAGE.
- 2UB3921-000102F PACKAGE: SEE "2UB3921-000102F SERIES" PACKAGE.
- FOR REFLOW SOLDERING LEAD-FREE PROCESS.
- OTHER GENERAL SPEC. TO REFER "2UB3921 SERIES SPEC".

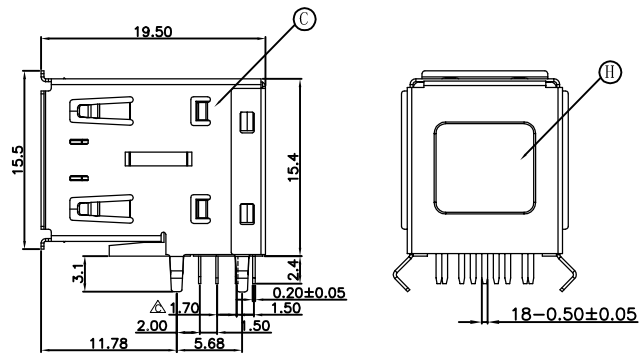
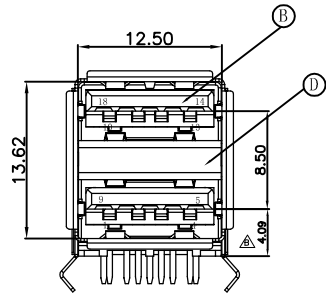
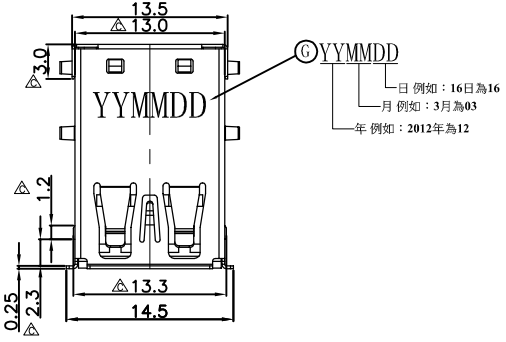

PART NO. 2UB3921-00010XF

- SUFFIX: HALOGEN FREE
- PACKAGE:
  - 1: TAPE & REEL
  - 2: TRAY
- HOUSING COLOR:
  - 0: BLUE(PMS 300C)
- CONTACT PLATING:
  - 1: 30u" Au PLATED ON CONTACT AREA,
  - 120u" MATTE TIN PLATED ON SOLDER AREA,
  - 50u" NI UNDERPLATED OVERALL.

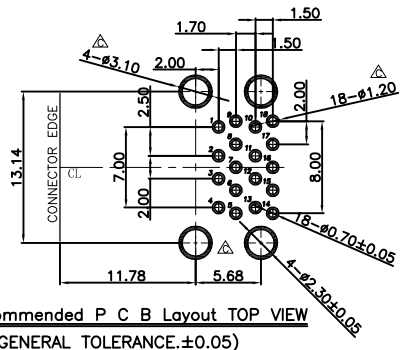
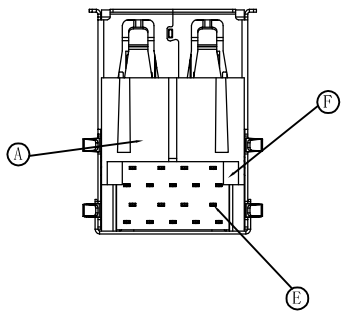

Recommended PCB Layout TOP VIEW  
(GENERAL TOLERANCE: ±0.05)

PIN ASSIGNMENTS

PIN NUMBER	SIGNAL NAME
1&10	VBUS
2&11	D-
3&12	D+
4&13	GND
5&14	StdA-SSR-
6&15	StdA-SSR+
7&16	GND-DRAIN
8&17	StdA-SST-
9&18	StdA-SST+
SHELL	SHIELD

NO	DESCRIPTION	QTY	MATERIAL	PLATING & COLOR
H	SHELL	1	STAINLESS STEEL	50u" Ni PLATED OVER ALL.
G	INK	-	INK	BLACK
F	SPACER	1	HIGH TEMP. THERMO-PLASTIC ,UL 94-V0	SEE PART NO.
E	CONTACT	18	COPPER ALLOY	SEE PART NO.
D	MIDDLE PLATE	1	STAINLESS STEEL	50u" Ni PLATED OVER ALL.
C	FRONT SHELL	1	STAINLESS STEEL	50u" Ni PLATED OVER ALL.
B	INNER INSULATOR	2	HIGH TEMP. THERMO-PLASTIC ,UL 94-V0	SEE PART NO.
A	HOUSING	1	HIGH TEMP. THERMO-PLASTIC ,UL 94-V0	SEE PART NO.

UNLESS OTHERWISE SPECIFIED TOLERANCES	Singatron Enterprise Co., Ltd. 信音企業股份有限公司
DECIMALS: ANGLES:	TITLE
X :±0.5 X :±2°	USB3.0 A TYPE FEMALE, DUAL TYPE, R/A, DIP TYPE
X.X :±0.3 X.X :±1°	DWN MY-C 2020.04.20 PART NO. 2UB3921-00010XF
X.XX :±0.2	CHKD ANGELA2020.04.20 SCALE 3:1 UNIT: mm
	APVD ANGELA2020.04.20 SIZE: A3 SHEET:1 OF 1 REV: C

CUSTOMER COPY

1 2 3 4 5 6 7 8