

REV.	ECN NO OR DESCRIPTION	REVISED	DATE
A	PDR NO:T150123-2A	ERIC-WU	2018.03.19

SPECIFICATIONS:

1. ELECTRICAL CHARACTERISTICS:

- 1-1. LLCR:
 - VBUS & GND PINS: 40mΩ /PIN MAX.
 - OTHER PINS: 40mΩ /PIN MAX.
 - LLCR MAX. CHANGE OF ALL PINS: 10mΩ.

1-2. CURRENT RATING: 3.0 A Max.

1-3. VOLTAGE RATING: 5.0 V.

1-4. INSULATION RESISTANCE: 100MΩ MIN.

1-5. ENVIRONMENTAL PERFORMANCE:

OPERATING TEMPERATURE: -55°C~+85°C.

2. MECHANICAL CHARACTERISTICS:

2-1. MATING FORCE : 0.5~2.0 Kgf.

2-2. UNMATING FORCE : 0.8~2.0 Kgf.

3. LIFE TEST: 10000 CYCLES MIN.

4. TO CONFORM TO SINGATRON HAZARDOUS SUBSTANCE FREE SPEC.

5. HALOGEN FREE PRODUCT IDENTIFICATION MARK ON JACK: 

6. HALOGEN FREE PRODUCT IDENTIFICATION LABEL ON PACKAGING: 

7. FOR REFLOW SOLDERING LEAD-FREE PROCESS.

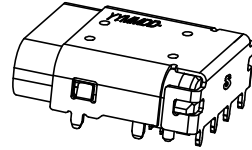

3D VIEW

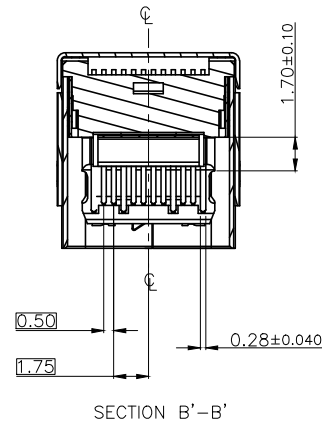
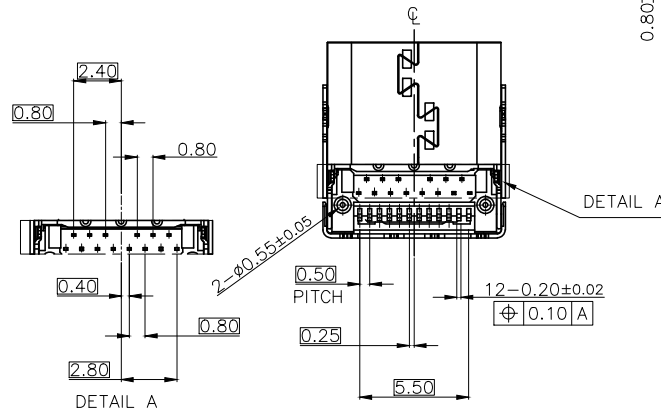
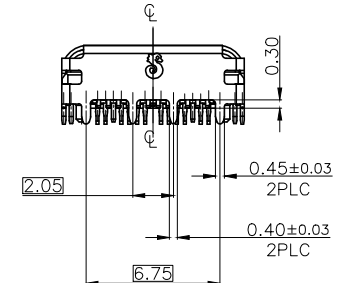
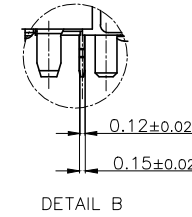
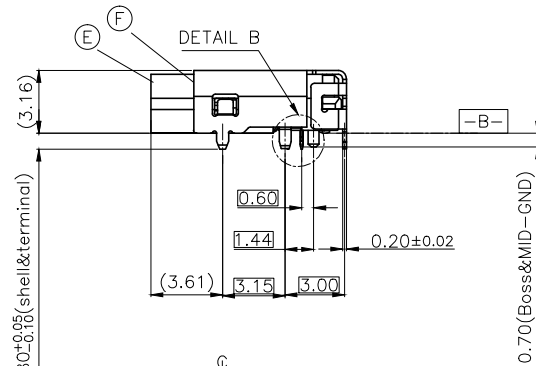
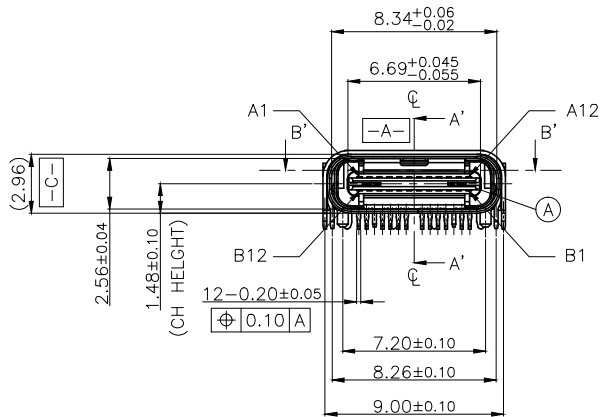
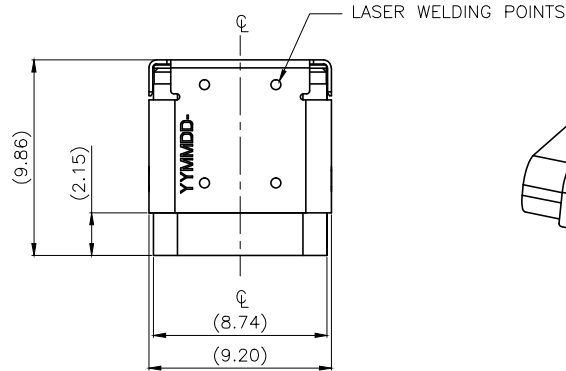

NO	DESCRIPTION	QTY	MATERIAL	PLATING & COLOR
F	TOP SHELL	1	STAINLESS STEEL,T=0.20	NICKEL 60u"MIN
E	SHELL	1	STAINLESS STEEL,T=0.20	NICKEL 60u"MIN
D	MATE GROUND	1	STAINLESS STEEL,T=0.10	N/A
C	MID GROUND	1	STAINLESS STEEL,T=0.15	NICKEL 60u"MIN
B	CONTACT	24	COPPER ALLOY, T=0.12	Au 2uIn+30uIn Pd/Ni PLATED ON CONTACT AREA; Matt. Sn 100uIn Min. PLATED ON SOLDERING 60uIn NICKEL UNDER PLATING OVERALL
A	BODY	1	HIGH TEMP.THERMOPLASTIC	BLACK

UNLESS OTHERWISE SPECIFIED TOLERANCES

DECIMALS:	ANGLES:
X :±0.5	X :±2°
X.X :±0.3	X.X :±1°
X.XX :±0.2	

 Singatron Enterprise Co., Ltd. 信音企業股份有限公司			
TITLE: USB TYPE -C FULL FEATURE CONN. TOP-MOUNT RECEPTACLE HYBRID TH AND SMT RIGHT ANGLE			
DWN	ERIC	PART NO: 2UB3C01-003111F	
CHKD	BOYE	SCALE:4:1	UNIT: mm
APVD	LIAO	SIZE: A3	SHEET:1 OF 2
REV:A			

CUSTOMER COPY

REV.	ECN NO OR DESCRIPTION	REVISED	DATE
A	PDR NO:T150123-2A	ERIC-WU	2018.03.19

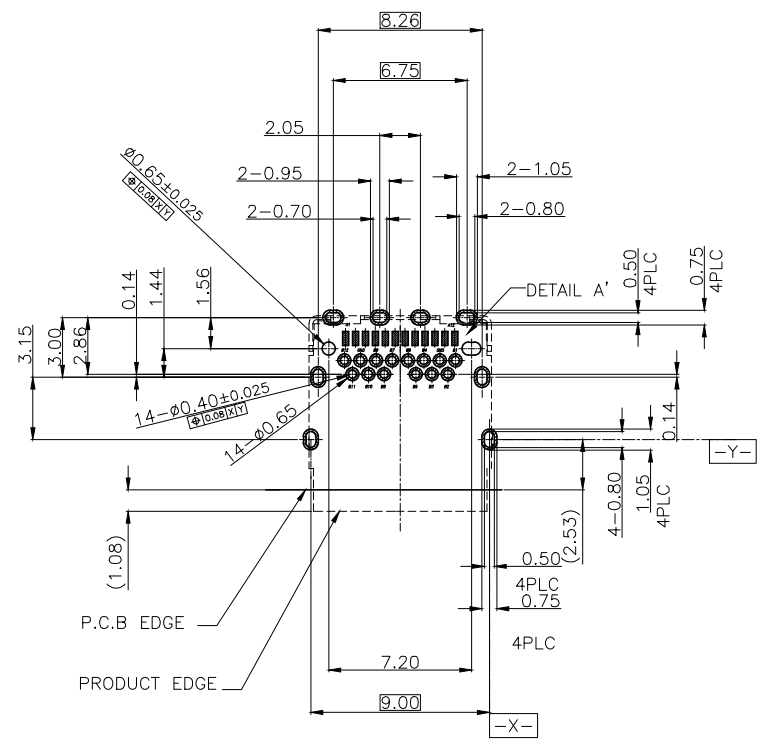

RECOMMENDED P.C.B LAYOUT(TOP VIEW)
TOLERANCE=±0.05(THK:1.6mm)

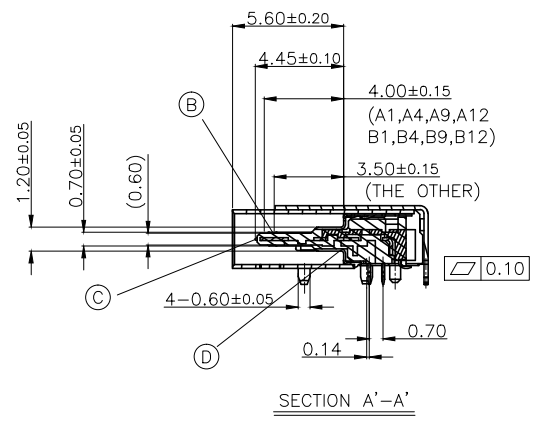
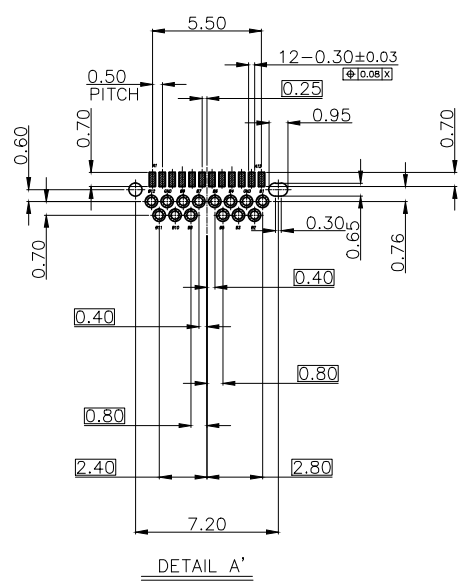

USB TYP-C PIN ASSIGNMENTS:

NO.	PIN NUMBER	SIGNAL NAME	NO.	PIN NUMBER	SIGNAL NAME
1	A1	GND	13	B12	GND
2	A2	SSTXp1	14	B11	SSRXp1
3	A3	SSTXn1	15	B10	SSRXn1
4	A4	VBUS	16	B9	VBUS
5	A5	CC1	17	B8	RFU2
6	A6	Dp1	18	B7	Dn2
7	A7	Dn1	19	B6	Dp2
8	A8	RFU1	20	B5	CC2
9	A9	VBUS	21	B4	VBUS
10	A10	SSRXn2	22	B3	SSTXn2
11	A11	SSRXp2	23	B2	SSTXp2
12	A12	GND	24	B1	GND

NO.	DESCRIPTION	QTY	MATERIAL	PLATING & COLOR
UNLESS OTHERWISE SPECIFIED TOLERANCES		Singatron Enterprise Co., Ltd. 信音企業股份有限公司		
DECIMALS: ANGLES:		TITLE: USB TYPE -C FULL FEATURE CONN. TOP-MOUNT RECEPTACLE HYBRID TH AND SMT RIGHT ANGLE		
X :±0.5	X :±2°	DWN	ERIC	PART NO: 2UB3C01-003111F
X.X :±0.3	X.X :±1°	CHKD	BOYE	SCALE:4:1 UNIT: mm
X.XX :±0.2		APVD	LIAO	SIZE: A3 SHEET:2 OF 2 REV:A
CUSTOMER COPY				