

REV.	ECN NO OR DESCRIPTION	REVISED	DATE
A	PDR NO:T150330-2A	ERIC-WU	2016.11.07
B	ECN NO: S170224-R	ERIC-WU	2017.02.11
C	ECN NO: S170821-O	ERIC-WU	2018.01.11
D	ECN NO: S202111-M03	TAO	2022.03.24

- SPECIFICATIONS:
- ELECTRICAL CHARACTERISTICS:
 - LLCR:
 - VBUS & GND PINS: 40mΩ /PIN MAX.
 - OTHER PINS: 40mΩ /PIN MAX.
 - LLCR MAX. CHANGE OF ALL PINS: 10mΩ.
 - CURRENT RATING: 3.0 A Max.
 - VOLTAGE RATING: 5.0 V.
 - INSULATION RESISTANCE: 100MΩ MIN.
 - ENVIRONMENTAL PERFORMANCE:
 - OPERATING TEMPERATURE: -55°C~+85°C.
 - MECHANICAL CHARACTERISTICS:
 - MATING FORCE : 5N~20N.
 - UNMATING FORCE : 8N~20N.
 - LIFE TEST: 10000 CYCLES MIN.
 - TO CONFORM TO SINGATRON HAZARDOUS SUBSTANCE FREE SPEC.
 - HALOGEN FREE PRODUCT IDENTIFICATION MARK ON JACK:
 - FOR REFLOW SOLDERING LEAD-FREE PROCESS.

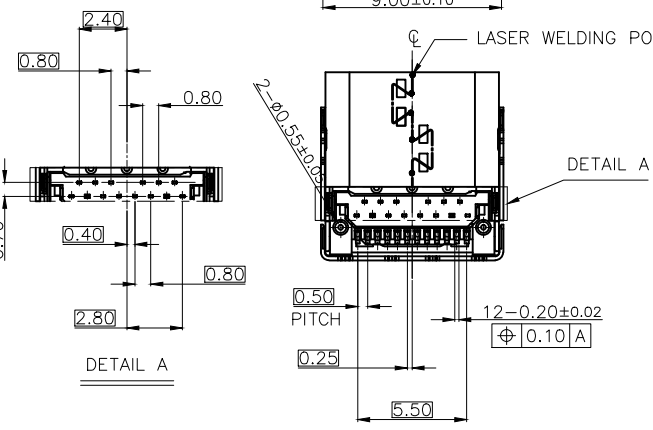
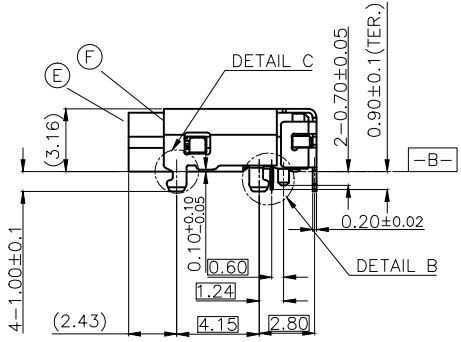
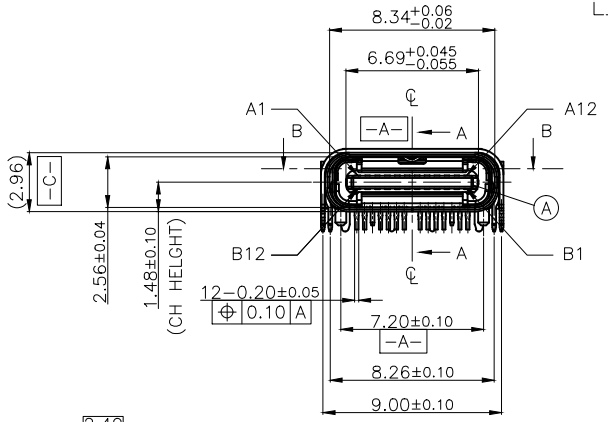
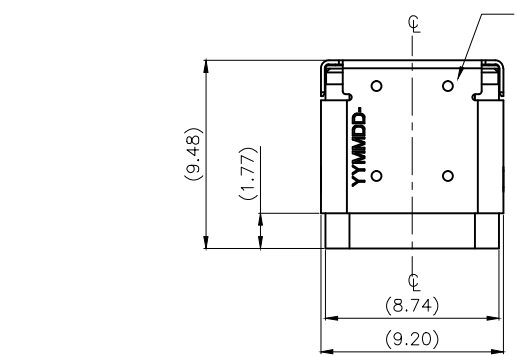
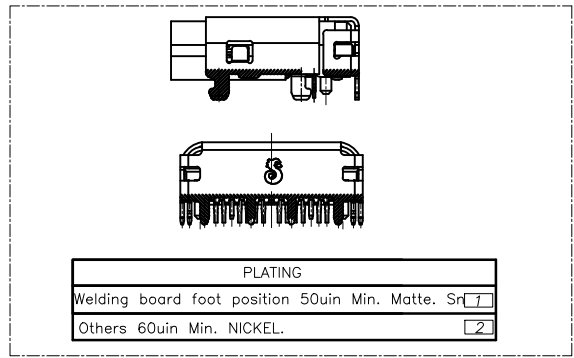

NO	DESCRIPTION	QTY	MATERIAL	PLATING & COLOR
F	TOP SHELL	1	SUS304,T=0.20	Welding board foot position 50uin Min. Matte. Sn; Others 60uin Min. NICKEL.
E	SHELL	1	SUS304,T=0.20	60uin Min. NICKEL;
D	MATE GROUND	1	SUS304,T=0.10	N/A
C	MID GROUND	1	SUS301,T=0.15	60uin Min. NICKEL;
B	CONTACT	24	C7035,T=0.12	2uin Au+30uin Pb/Ni PLATED ON CONTACT AREA 100uin Min. Matte. Sn PLATED ON SOLDERING AREA; ALL OVER 60uin NICKEL PLATING.
A	BODY	1	LCP 6808U	BLACK

UNLESS OTHERWISE SPECIFIED TOLERANCES		Singatron Enterprise Co., Ltd. 信音企業股份有限公司	
DECIMALS:	ANGLES:	TITLE: USB TYPE -C FULL FEATURE CONN. TOP-MOUNT RECEPTACLE HYBRID TH AND SMT RIGHT ANGLE	
X :±0.5	X :±2°	DWN	TAO PART NO: 2UB3C01-008111F
X.X :±0.3	X.X :±1°	CHKD	Boye SCALE:4:1 UNIT: mm
X.XX :±0.2		APVD	Liao SIZE: A3 SHEET:1 OF 2 REV:D
CUSTOMER COPY			

REV.	ECN NO OR DESCRIPTION	REVISED	DATE
A	PDR NO:T150330-2A	ERIC-WU	2016.11.07
B	ECN NO: S170224-R	ERIC-WU	2017.02.11
C	ECN NO: S170821-O	ERIC-WU	2018.01.11
D	ECN NO: S202111-M03	TAO	2021.09.09

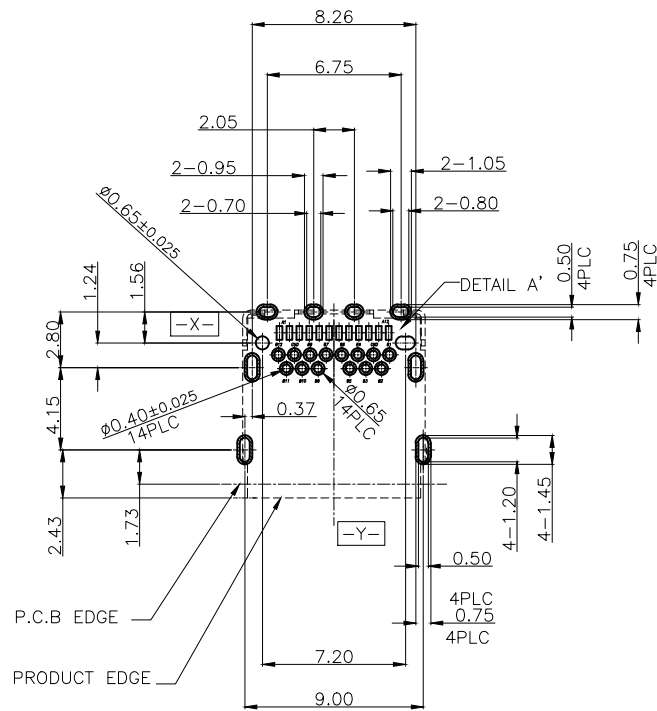

RECOMMENDED P.C.B LAYOUT(TOP VIEW)
TOLERANCE=±0.05(THK: 1.6mm)

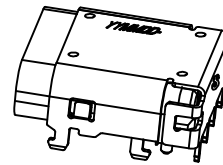
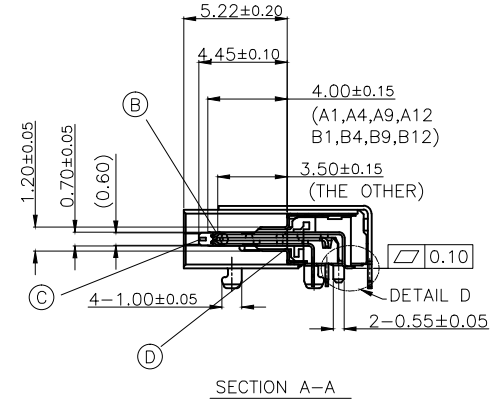
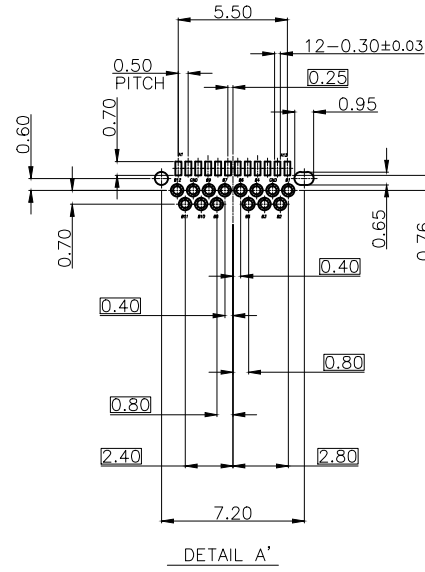
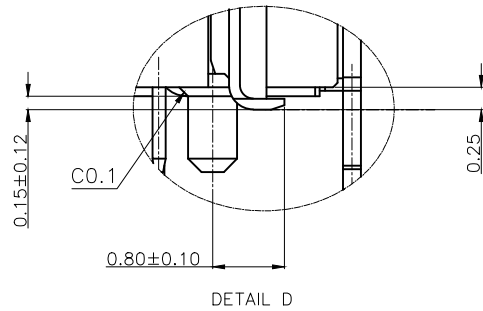

3D VIEW

PIN ASSIGNMENT											
A1	A2	A3	A4	A5	A6	A7	A8	A9	A10	A11	A12
GND	TX1-	TX1-	VBUS	CC1	D+	D-	RFU1	VBUS	RX2-	RX2+	GND
GND	RX1+	RX1-	VBUS	RFU2	D-	D+	CC2	VBUS	TX2-	TX2-	GND
B12	B11	B10	B9	B8	B7	B6	B5	B4	B3	B2	B1
NO	DESCRIPTION	QTY	MATERIAL	PLATING & COLOR							
UNLESS OTHERWISE SPECIFIED TOLERANCES				Singatron Enterprise Co., Ltd. 信音企業股份有限公司							
DECIMALS: ANGLES:				TITLE: USB TYPE -C FULL FEATURE CONN. TOP-MOUNT RECEPTACLE HYBRID TH AND SMT RIGHT ANGLE							
X	:±0.5	X	:±2°	DWN TAO PART NO: 2UB3C01-008111F							
X.X	:±0.3	X.X	:±1°	CHKD	Boye	SCALE:4:1	UNIT: mm				
X.XX	:±0.2	APVD	Liao	SIZE: A3	SHEET:2 OF 2	REV:D					
CUSTOMER COPY											