

REV	ECN NO OR DESCRIPTION	REVISED	DATE
A	PDR NO.:T171129-2A	Edi.Zhou	2018.04.02

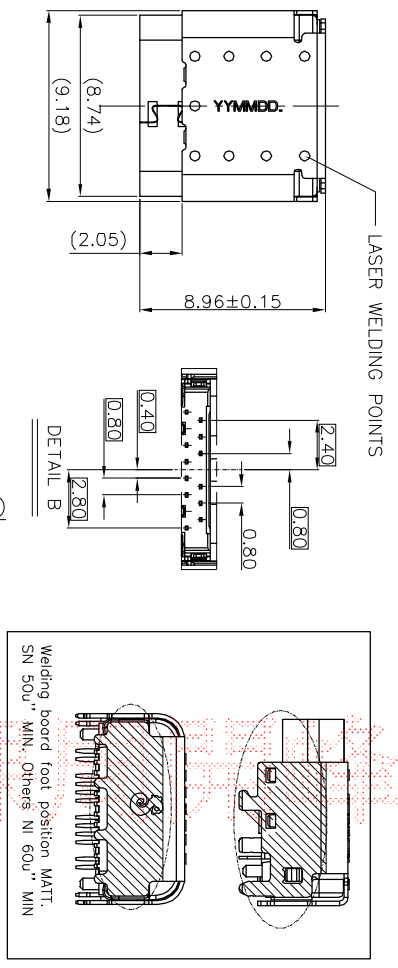

- SPECIFICATIONS:
- ELECTRICAL CHARACTERISTICS:
 - LCCR: YBUS & GND PINS: 40mΩ /PIN MAX. OTHER PINS: 40mΩ /PIN MAX. LCCR MAX. CHANGE OF ALL PINS: 10mΩ.
 - CURRENT RATING: 3.0 A Max.
 - VOLTAGE RATING: 5.0 V.
 - INSULATION RESISTANCE: 100MΩ MIN.
 - ENVIRONMENTAL PERFORMANCE: OPERATING TEMPERATURE: -55°C--+85°C.
 - MECHANICAL CHARACTERISTICS:
 - MATING FORCE : 0.5-2.0 Kgf.
 - UNMATING FORCE : 0.8-2.0 Kgf.
 - LIFE TEST: 10000 CYCLES MIN.
 - TO CONFORM TO SINGATRON HAZARDOUS SUBSTANCE FREE SPEC.
 - HALOGEN FREE PRODUCT IDENTIFICATION MARK ON JACK: Ⓢ
 - HALOGEN FREE PRODUCT IDENTIFICATION LABEL ON PACKAGING: 7. FOR REFLOW SOLDERING LEAD-FREE PROCESS.

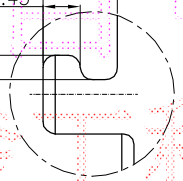
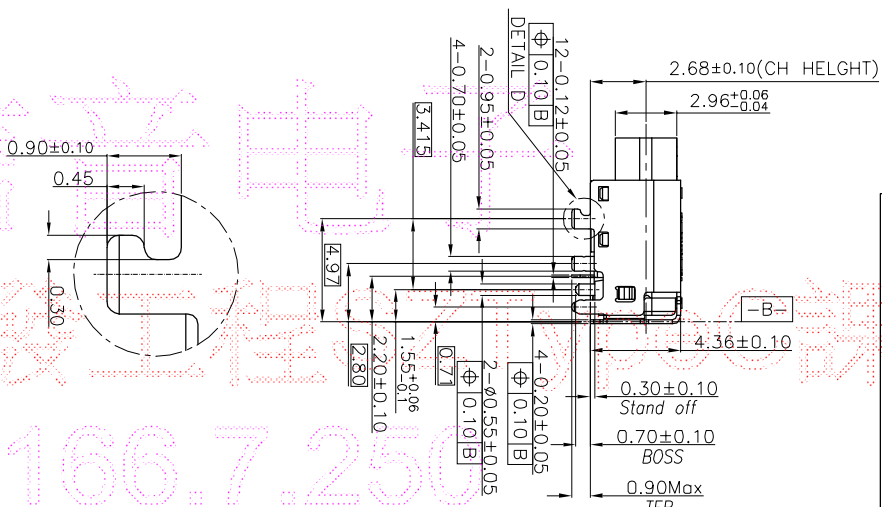
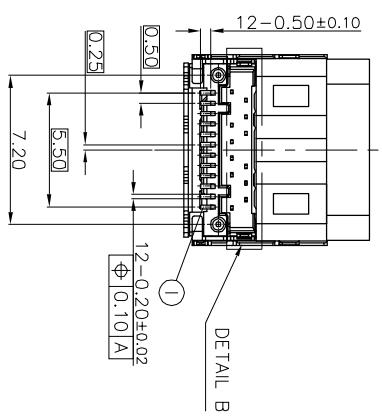
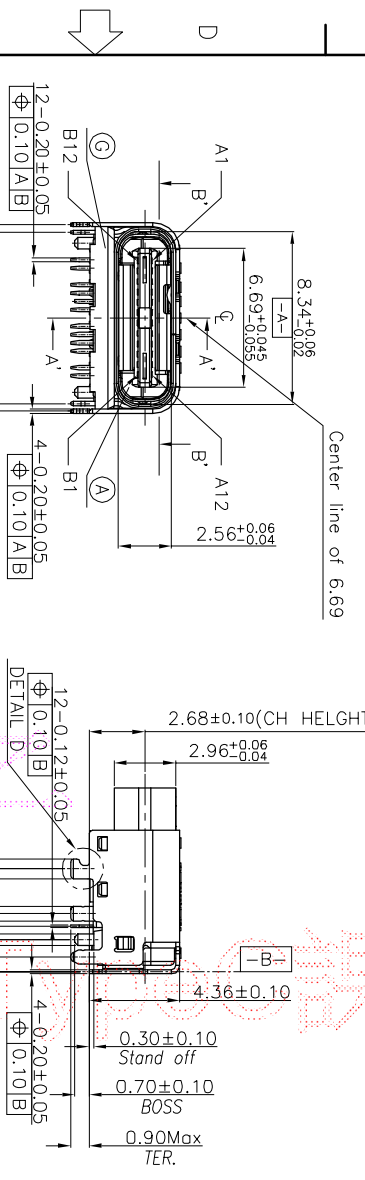

SCALE: 4:1

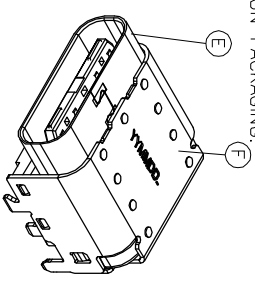
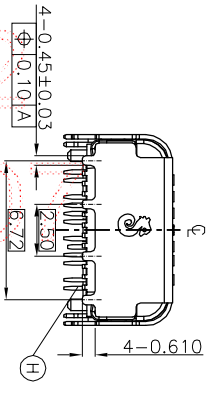

NO	DESCRIPTION	QTY	MATERIAL	PLATING & COLOR
A	WELDING-2	1	LCP6808-UFV	BLACK
B	MOLDING-1	1	LCP6808-UFV	BLACK
C	MID GROUND	1	SUS301-EH1=0.15	N/A
D	WATE GROUND	1	SUS304-1/2H,T=0.10	N/A
E	SHELL	1	SUS304-1/2H,T=0.20	Weldable Nickel 60-120u"
F	TOP SHELL	1	SUS304-1/2H,T=0.20	SN 50u" MIN. Others NI 60u" MIN
G	COVER	1	PAGT-GP2450	BLACK
H	DIP CONTACTS	12	NKC4419, T=0.12	50u" Min. Ni UNDERPLATED OVERALL 450u" Min. PLATED ON CONTACT AREA C/F PLATED ON SOLDER AREA
I	SMT CONTACTS	12	NKC4419, T=0.12	50u" Min. Ni UNDERPLATED OVERALL 450u" Min. PLATED ON CONTACT AREA C/F PLATED ON SOLDER AREA

DECIMALS:	ANGLES:
X :+0.5	X :±2'
X.X :+0.3	X.X :±1'
X.XX :+0.2	

TITLE	USB TYPE -C FULL FEATURE CONN. TOP-MOUNT RECEPTACLE HYBRID TH AND SMT RIGHT ANGLE
Edi.Zhou	Edi.Zhou
PART NO: 2UB3C01-032111F	PART NO: 2UB3C01-032111F
SCALE:1:1	SCALE:1:1
UNIT: mm	UNIT: mm
SIZE: A3	SIZE: A3
SHEET:1 OF 2	SHEET:1 OF 2
REV:A	REV:A

Singatron Enterprise Co., Ltd.
信晋企业股份有限公司

CUSTOMMER COPY

REV	ECN NO OR DESCRIPTION	REVISED	DATE
A	PDR NO.:1711129-2A	Edi.Zhou	2018.04.02

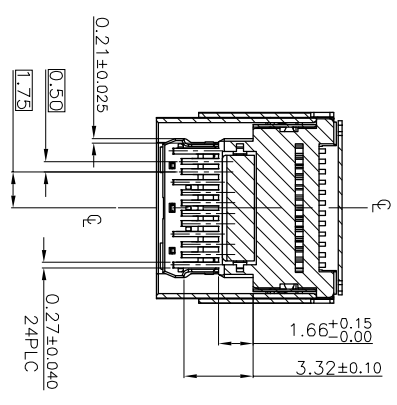

Cutting Place B'-B'

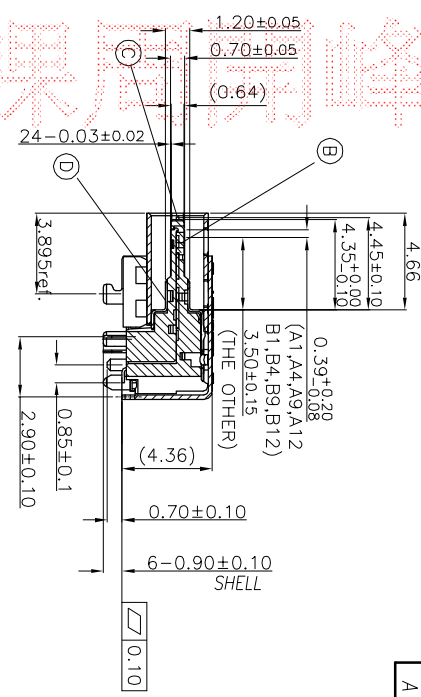

Cutting Place A'-A'

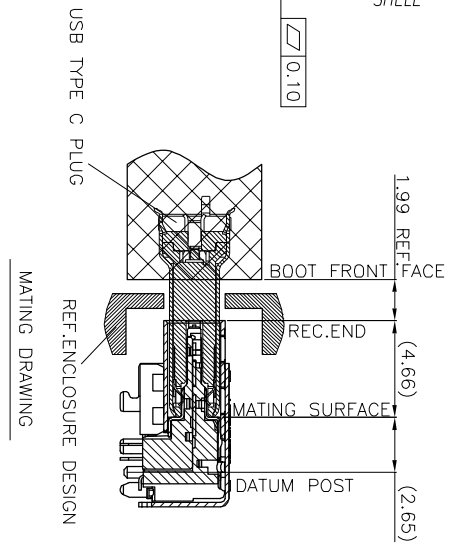

MATING DRAWING

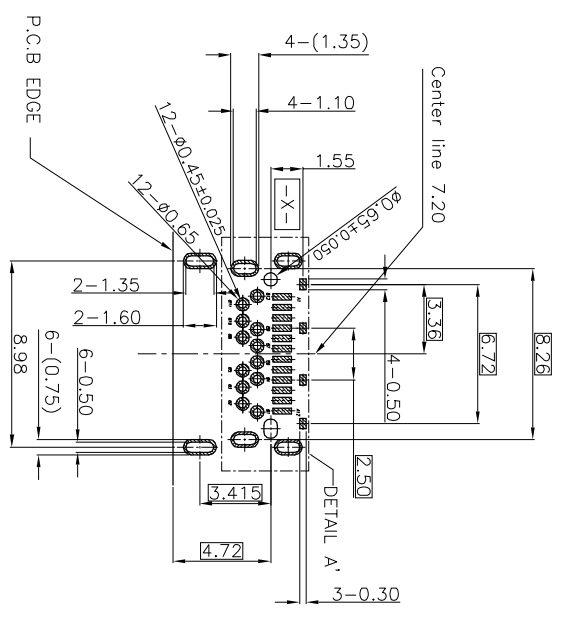

RECOMMENDED P.C.B LAYOUT(TOP VIEW)
TOLERANCE=±0.05(THK:1.0mm)

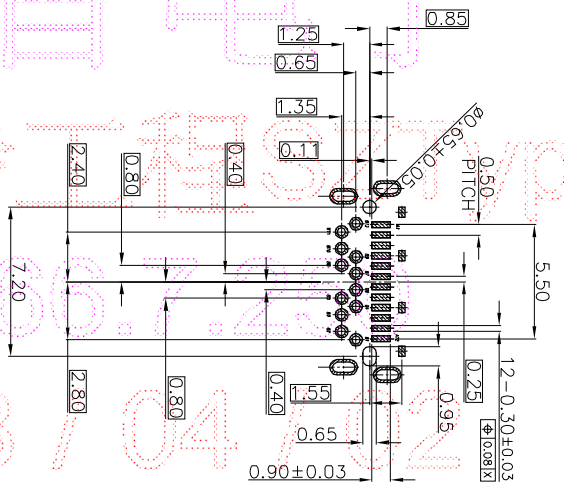

DETAIL A'

USB TYPE-C PIN ASSIGNMENTS:

NO	DESCRIPTION	QTY	MATERIAL	PLATING & COLOR
1	A1	GND		
2	A2	SSTXp1		
3	A3	SSTXn1		
4	A4	VBUS		
5	A5	CC1		
6	A6	Dp1		
7	A7	Dn1		
8	A8	RFU1		
9	A9	VBUS		
10	A10	SSRXn2		
11	A11	SSRXp2		
12	A12	GND		

NO	DESCRIPTION	QTY	MATERIAL	PLATING & COLOR
UNLESS OTHERWISE SPECIFIED TOLERANCES				
Singatron Enterprise Co., Ltd. 信音企業股份有限公司				
TITLE: USB TYPE - C FULL FEATURE CONN.				
TOP-MOUNT RECEPTACLE HYBRID TH AND SMT RIGHT ANGLE				
DWG: Edi.Zhou				
CHKD: Edi.Zhou				
APVD: Edi.Zhou				
SCALE:1:1				
UNIT: mm				
SIZE: A3				
SHEET:2 OF 2				
REV:4				
CUSTOMER COPY				

信音电子
 研发工程 SMT/PCB 课 周周峰
 10.186.72.22
 2018 / 04 / 02
 08:17:07

A B C D E F

1 2 3 4 5 6 7 8